

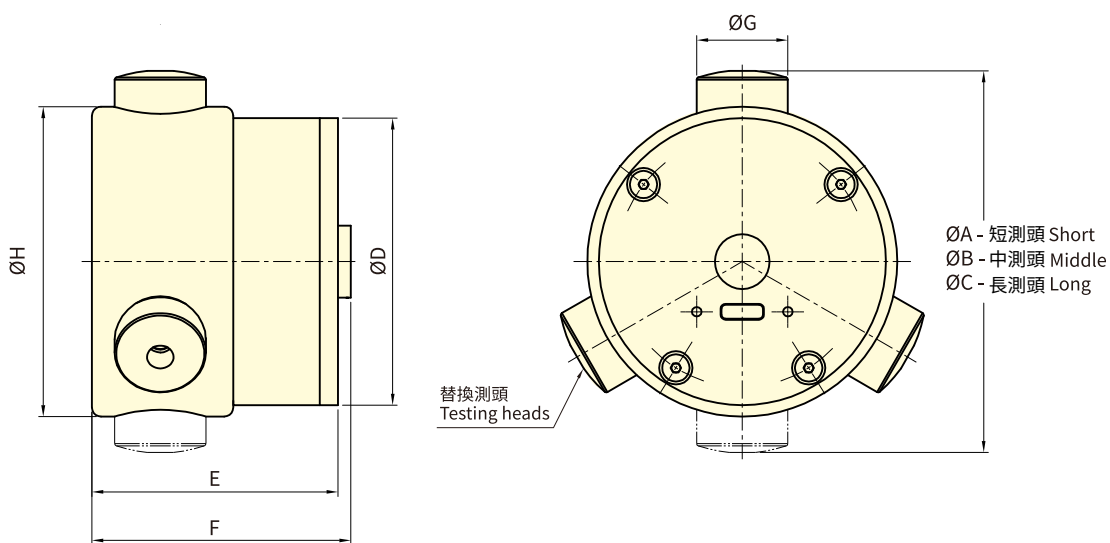

- 藍牙 5.0 傳輸穩定：擁有最新的藍牙 5.0 技術，確保無線連接的穩定性。
 - Type-C 充電便利：支援 Type-C 充電，讓充電更加便捷。
 - 高性能鋰電池：提供更長的續航時間，讓您在工作中無需擔心電量問題。
 - 支援 Android 和 iOS：無論您使用的是 Android 還是 iOS 系統，GFS-100 都能夠完美兼容，讓您無縫體驗。
 - 可配置 2 爪或 3 爪操作：根據您的實際需求，GFS-100 可以輕鬆配置為 2 爪或 3 爪操作，提供更大的彈性。
 - 注意：第一代夾持力感測器 (GFS-100) 和第二代的夾持力感測器 (GFS-100) APP 不能共用。
 - iOS 系統：Apple iOS 16.1.2 版本以上。Android 系統：Android 12 版本或以上。
- Stable Bluetooth 5.0 Transmission: Equipped with the latest Bluetooth 5.0 technology, ensuring stability in wireless connections.
 - Convenient Type-C Charging: Supports Type-C charging for added convenience in recharging.
 - High-Performance Lithium Battery: Provides a longer-lasting battery life, eliminating concerns about power during work.
 - Supports Android and iOS: Whether you use Android or iOS systems, the GFS-100 is perfectly compatible, offering a seamless experience.
 - Configurable for 2-Jaw or 3-Jaw Operation: Based on your specific needs, the GFS-100 can easily be configured for either 2-jaw or 3-jaw operation, providing greater flexibility.
 - Note: The first-generation gripping force sensor (GFS-100) and the second-generation gripping force sensor (GFS-100) APP are not compatible and cannot be used interchangeably.
 - iOS System: Apple iOS 16.1.2 ◦ Android System: Android version 12.



保留規格修改的權利 Subject to technical changes

技術規格 SPECIFICATIONS

型號	最大夾持力(單爪)	最高轉速	夾持範圍	準確度
Model	Max. Load (1-jaw)	Max. Speed	Gripping range	Accuracy
	(kN)	(r.p.m.)	(mm)	
GFS-100	100	6000	70, 84, 104	±2%

外型尺寸 DIMENSIONS

Model	A	B	C	D	E	F	G	H
GFS-100	70	84	104	63	54	57	20	68

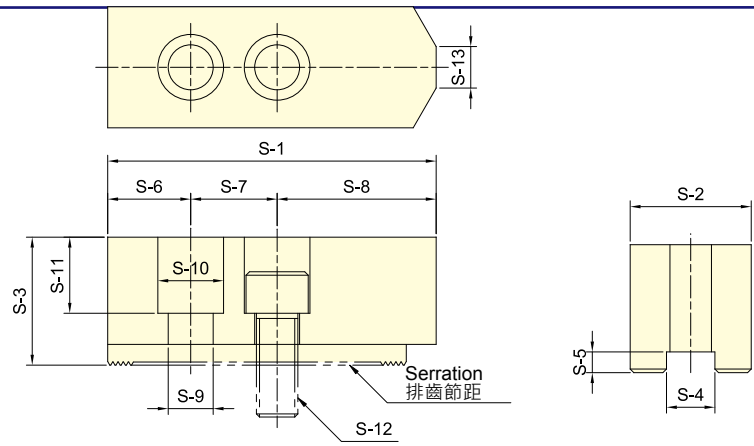

外型尺寸 DIMENSIONS

保留規格修改的權利 Subject to technical changes

型號	S-1	S-2	S-3	S-4	S-5	S-6	S-7	S-8	S-9	S-10	S-11	S-12	S-13	排齒節距	適用夾頭	三爪重量
MODEL														Serration Pitch	Matching Chuck	3 Jaw Weight kg
SJ-04	52	23	23	10	5	10	14	28	9	14	13	M8	3	1.5 × 60°	3H-204, 3P-04	0.5
SJ-05	62	25	30	10	5	10	14	38	9	14	20	M8	3.5	1.5 × 60°	3H-205, 3L-205, 3P-05, 3M-05	0.8
SJ-06	73	31	36	12	5	15	20	38	11	17	24	M10	14	1.5 × 60°	3H-206, 3L-206, 3P-06, 3M-06	1.5
SJ-08	95	35	37	14	5	24	25	46	13	19	22	M12	16	1.5 × 60°	3H-208, 3L-208, 3P-08, 3M-08	2.4
SJ-10	110	40	42	16	5	30	30	50	13	19	27	M12	18	1.5 × 60°	3H-210, 3L-210, 3P-10, 3M-10	3.7
*SJ-12H	130	50	50	21	5	40	30	60	17	25	30	M16	23	1.5 × 60°	3H-12, 3H-212, 3L-212, 3V-12, 3P-12, 3M-12	6.3
SJ-12P	130	50	50	18	5	40	30	60	16	23	30	M14	23	1.5 × 60°	3H-12, 3H-212, 3L-212, 3V-12, 3P-12, 3M-12	6.5
SJ-15H	165	62	62	22	8	37	43	85	21	32	37	M20	-	1.5 × 60°	3H-15, 3H-215, 3H-18, 3L-15, 3P-215, 3P-218, 3V-15, 3V-18	12.6
*SJ-15P	165	62	62	25.5	6	37	43	85	21	32	37	M20	-	1.5 × 60°	3H-15, 3H-215, 3H-18, 3L-15, 3P-215, 3P-218, 3V-15, 3V-18	12.5
SJ-21	180	64	70	25	9	40	60	80	21	32	45	M20	-	3.0 × 60°	3H-221, 3H-224, 3H-232, 3P-221, 3P-224, 3V-21, 3V-24, 3V-32 3M-221, 3M-224, SP-320, SP-324	15.8

* SJ-12H 為 12" 夾頭出廠配備。(12" Chucks are originally equipped with SJ-12H.)

* SJ-15P 為 15" 夾頭出廠配備。(15" Chucks are originally equipped with SJ-15P.)

3U 夾頭之標準生爪 STANDARD SOFT JAW FOR 3U CHUCK

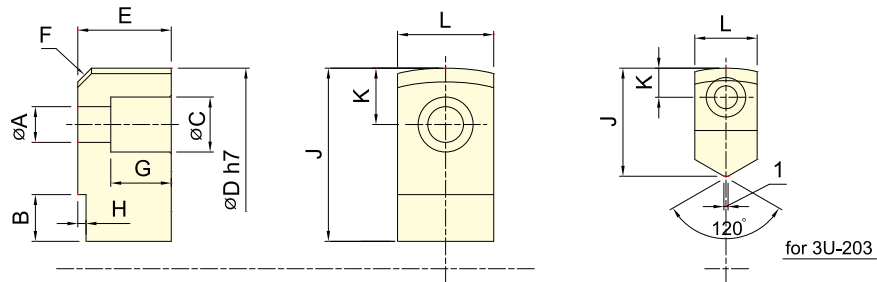

外型尺寸 DIMENSIONS

保留規格修改的權利 Subject to technical changes

型號	A	B	C	D	E	F	G	H	J	K	L
MODEL											
3U-203	5.5	11	9.5	66	12	C3	7	3	26	7	15
3U-204	6.6	11	11	84	17	C4	11	3	32	9.5	20
3U-205	9	13.5	14	108	20	C4	12	3	41.5	13	24
3U-206	11	15	17	129	30	C6	20	3	50	17	30
3U-208	13	17	20	156	34	C6	22	3	63	20.5	35
3U-210	15	20	22	187	39	C6	24	4	74	23	40
3U-212	15	18	22	234	44	C6	29	4	72	23	40

2D/3D 夾頭之標準生爪 Standard Soft Jaw for 2D/3D chuck

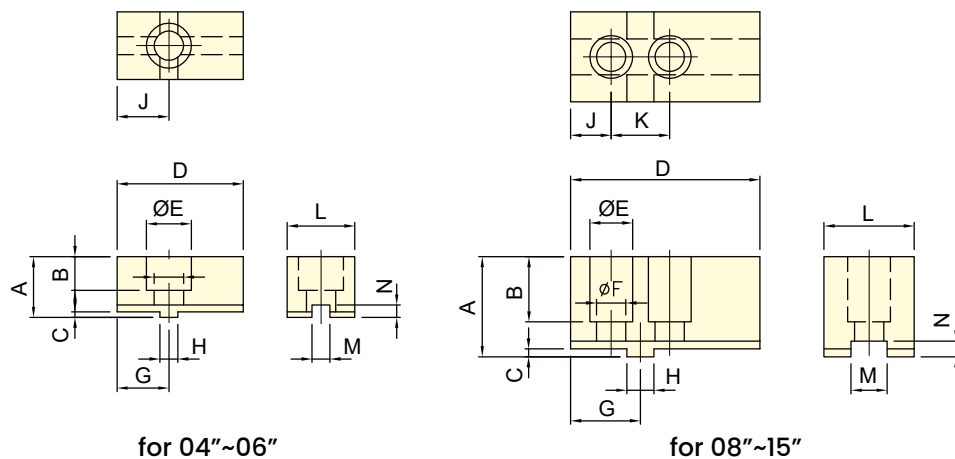

保留規格修改的權利
Subject to technical changes

外型尺寸 DIMENSIONS

型號 MODEL	A	B	C	D	E	F	G	H	J	K	L	M	N
3D-04	22	13	2.5	52	17.5	11	19	8	19	-	25	8	5.5
3D-05	27	15	2.5	56	20	13	23	8	23	-	30	8	5.5
3D-06	34	21	3	70	23	15.5	27	10	27	-	35	10	6
3D-08	44.5	29	3.5	84	19	13	31	12	18	26	40	16	7
3D-10	49.5	32	3.5	100	22	15	38	15	22	32	50	18	7
3D-12	54.5	36	3.5	120	26	18	42	17	24	36	60	20	7
3D-15	65	40	5	165	26	18	60	20	40	40	70	24	10

3E 夾頭之標準生爪 Standard Soft Jaw for 3E chuck

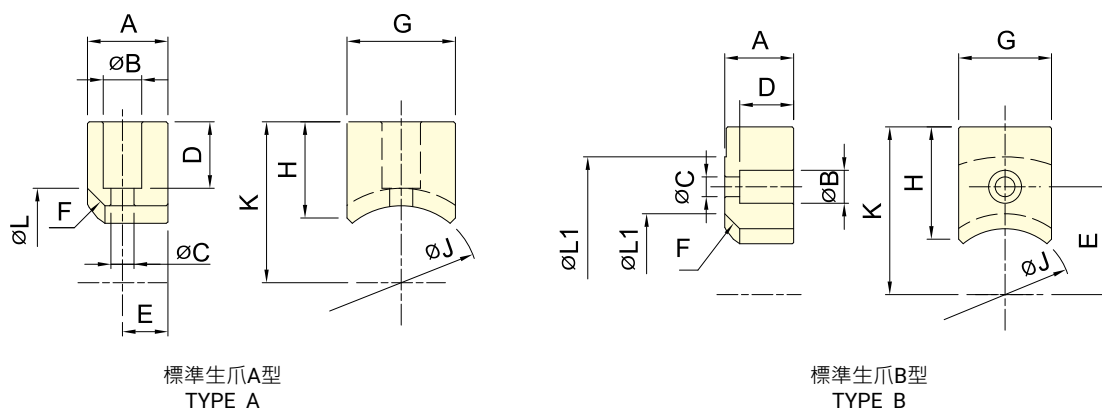

保留規格修改的權利
Subject to technical changes

外型尺寸 DIMENSIONS

型號 MODEL	A	B	C	D	E	F	G	H	J	K	L	L1	
3E-05	A 型	20	11	6.6	16.5	10	C5	25	22	29	34.5	39	-
	B 型	20	11	6.6	15	25.5	C5	25	30	29	42.5	39	69
3E-06	A 型	23	11	7	19	13	C5	31	27.5	44	46	54	-
	B 型	23	11	6.6	18	36	C5	31	37.5	44	56	54	92
3E-08	A 型	30	14	9	25	15	C6	35	36	50	56	62	-
	B 型	30	14	9	24	41	C6	35	56	50	76	62	112
3E-10	A 型	35	17.5	11	26.5	17.5	C5	40	40	60	64.5	70	-
	B 型	35	17.5	11	26	47.5	C5	40	71.5	60	96	70	129

3R 夾頭之標準生爪 Standard Soft Jaw for 3R chuck

零件與其他

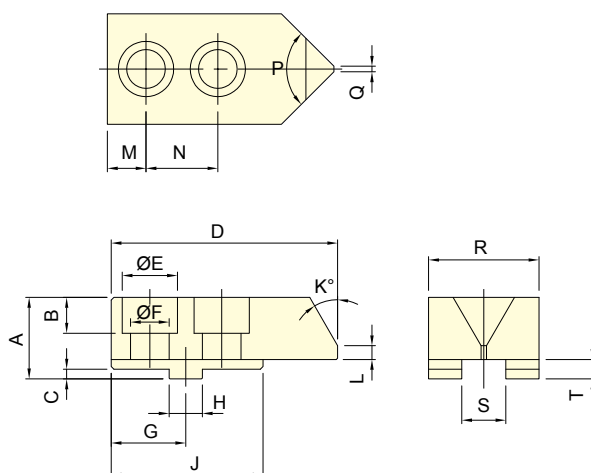

保留規格修改的權利
Subject to technical changes

外型尺寸 DIMENSIONS

型號 MODEL	A	B	C	D	E	F	G	H	J	K	L	M	N	P	Q	R	S	T
3R-08	29.5	13	3.5	82	20	14	27	12	55	30	5	14	26	90	2	40	16	7
3R-10	30.5	15	3.5	102	23	16	37	15	65	30	7	21	32	90	2	40	18	7

3W 夾頭之標準生爪 Standard Soft Jaw for 3W chuck

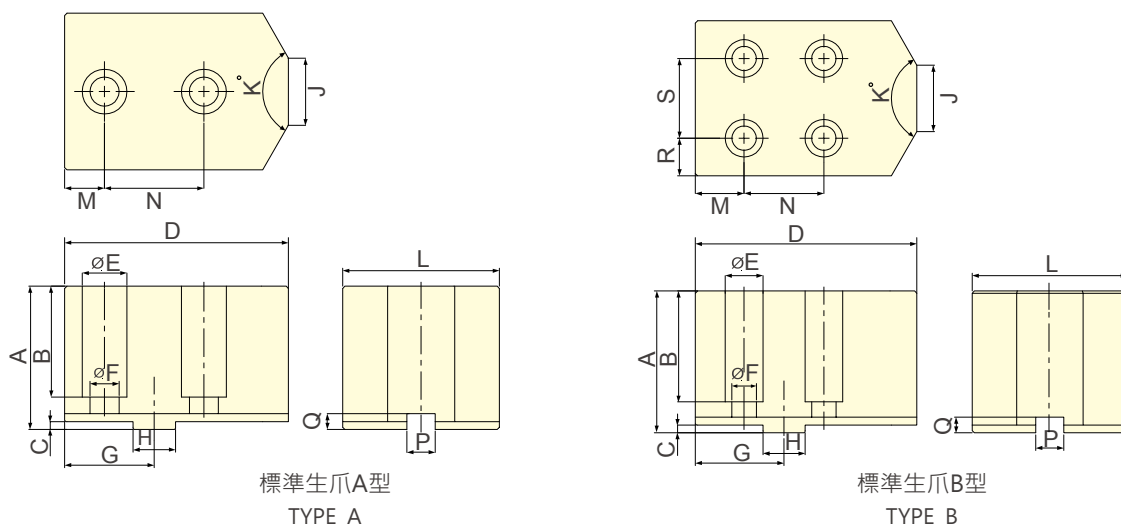

保留規格修改的權利 Subject to technical changes

外型尺寸 DIMENSIONS

型號 MODEL	A	B	C	D	E	F	G	H	J	K	L	M	N	P	Q	R	S	
3W-08	A 型	60	44	3.5	80	20	13	35	12.68	30	120	57	16	38	7.94	7	-	-
	B 型	60	48	3.5	80	17	11	35	12.68	30	120	57	19	32	7.94	7	12.5	32
3W-10	A 型	64	49.5	3.5	100	20	13	40	19.03	30	120	70	17.8	44.4	12.7	7	-	-
	B 型	64	50	3.5	100	17	11	40	19.03	30	120	70	22	36	12.7	7	17	36
3W-12	A 型	64	49.5	3.5	100	20	13	40	19.03	30	120	70	17.8	44.4	12.7	7	-	-
	B 型	64	50	3.5	100	17	11	40	19.03	30	120	70	22	36	12.7	7	17	36

*3W 系列軟爪可搭配鎢鋼爪，根據工件條件選擇鎢鋼爪型式，訂製生產。

*3W series Carbide gripper is optional. * The type of the gripper is selected according to the work-piece conditions.

3MF 夾頭之標準生爪 Standard Soft Jaw for 3MF chuck

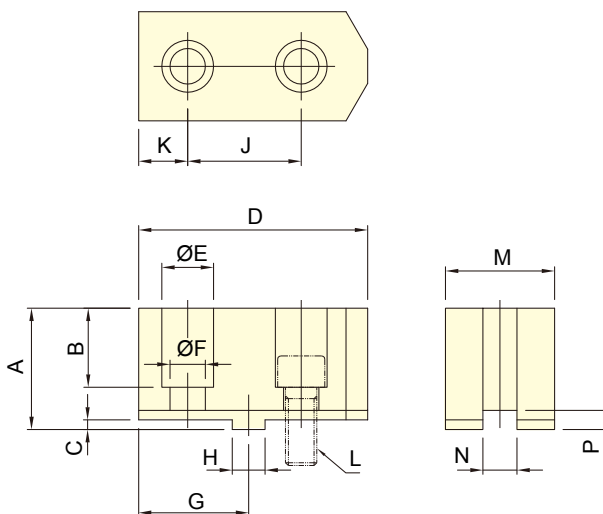

保留規格修改的權利
Subject to technical changes

外型尺寸 DIMENSIONS

型號 MODEL	A	B	C	D	E	F	G	H	J	K	L	M	N	P	三爪重量 (kg) 3 Jaw Weight
3MF-20	70	48	6	160	25	17	80	19.03	76.2	41.9	M16	50	12.7	11.5	10.4

AP 夾頭之標準生爪 Standard Soft Jaw for AP chuck

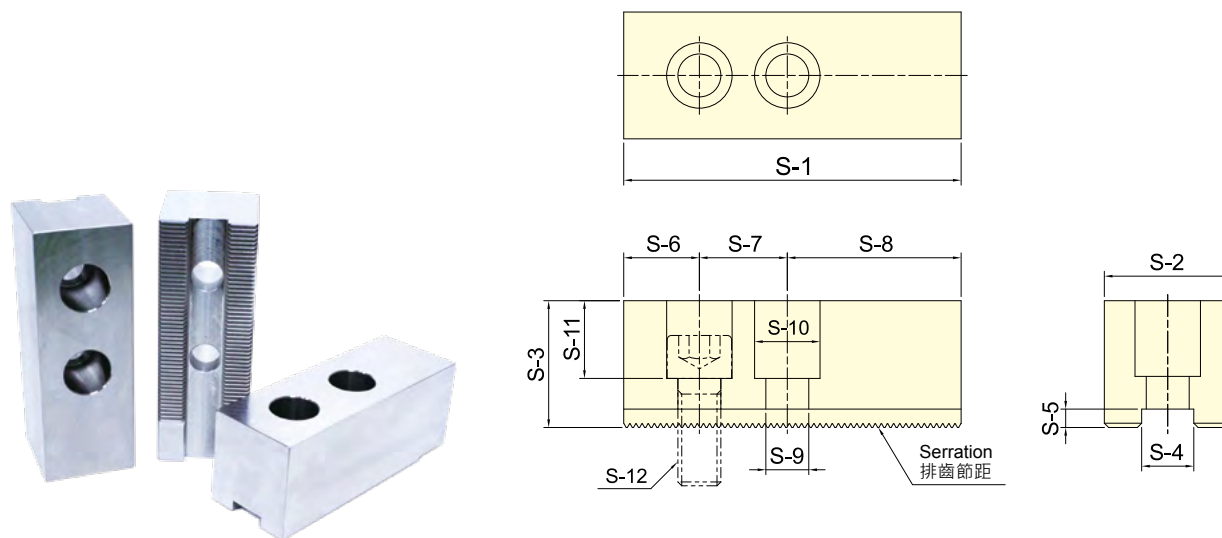

保留規格修改的權利
Subject to technical changes

外型尺寸 DIMENSIONS

型號 MODEL	S-1	S-2	S-3	S-4	S-5	S-6	S-7	S-8	S-9	S-10	S-11	S-12	排齒節距 Serration Pitch	適用夾頭 Matching Chuck	三爪重量 (kg) 3 Jaw Weight
SJ-185	165	62	62	25.5	9	37	43	85	21	32	38	M20	3.0 × 60 °	AP-145, AP-185	12.2
SJ-275	180	64	70	25.5	9	40	60	80	21	32	45	M20	3.0 × 60 °	AP-230, AP-275	16.1
SJ-320	210	75	80	30	9	40	60	110	26	38	55	M24	3.0 × 60 °	AP-320, AP-375	24.7

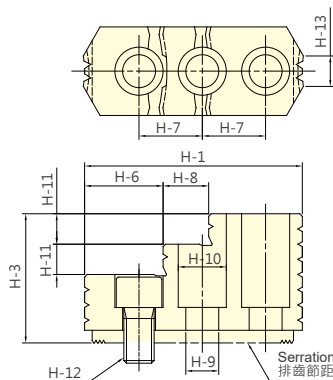
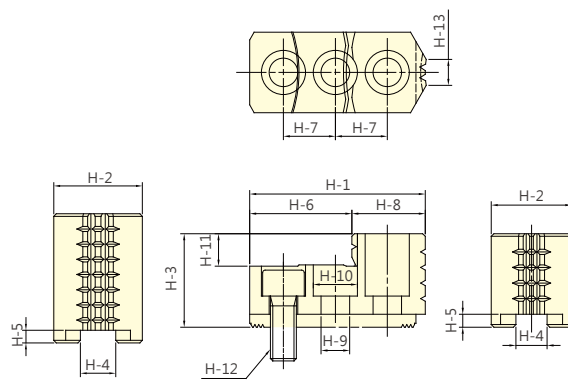
Fig. 1

Fig. 2

保留規格修改的權利
Subject to technical changes

外型尺寸 DIMENSIONS

型號 MODEL	H-1	H-2	H-3	H-4	H-5	H-6	H-7	H-8	H-9	H-10	H-11	H-12	H-13	排齒節距 Serration Pitch	適用夾頭 Matching Chuck	三爪重量 3 Jaw Weight kg	參考圖 Reference Drawing
HJ-06	67.6	31	36	12	5	40.2	20	27.4	11	17	12	M10	9.3	1.5 × 60°	3H-206, 3P-06	1.7	Fig.2
HJ-08	86.1	35	51	14	5	33.5	25	18.4	13	19	12	M12	14	1.5 × 60°	3H-208, 3P-08	2	Fig.1
HJ-10	100	40	54	16	5	39.5	30	22.5	13	19	13	M12	15	1.5 × 60°	3H-210, 3P-10	3	Fig.1
*HJ-12H	100.2	50	52	21	5	64.7	30	35.5	17	25	17	M16	31.5	1.5 × 60°	3H-12,3H-212, 3L-212, 3V-12,3P-12, 3M-12	3.5	Fig.2
*HJ-12P	100.2	50	52	18	5	64.7	30	35.5	15	23	17	M14	31.5	1.5 × 60°	3H-12,3H-212, 3L-212, 3V-12,3P-12, 3M-12	3.6	Fig.2
*HJ-15H	140.7	62	86	22	8	62.5	43	34	21	32	20	M20	43	1.5 × 60°	3H-15, 3H-215, 3H-18, 3L-15 3V-15, 3V-18,3P-215, 3P-218	9.6	Fig.1
*HJ-15P	140.7	62	86	25.5	6	62.5	43	34	21	32	20	M20	43	1.5 × 60°	3H-15, 3H-215, 3H-18, 3L-15 3V-15, 3V-18,3P-215, 3P-218	9.5	Fig.1
HJ-21	153.5	80	90	25	9	103.7	50	49.8	21	32	40	M20	56.5	3.0 × 60°	3H-221, 3H-224, 3H-232, 3P-221, 3P-224, 3V-21, 3V-24, 3V-32	14.3	Fig.2

* HJ-12H、HJ-12P、HJ-15H、HJ-15P 選用前請確認 H-4 的尺寸。

* For HJ-12H, HJ-12P, HJ-15H, HJ-15P, please confirm the dimension of H-4 before placing the order.

3MF 標準硬爪

STANDARD HARDEN JAW FOR 3MF CHUCK

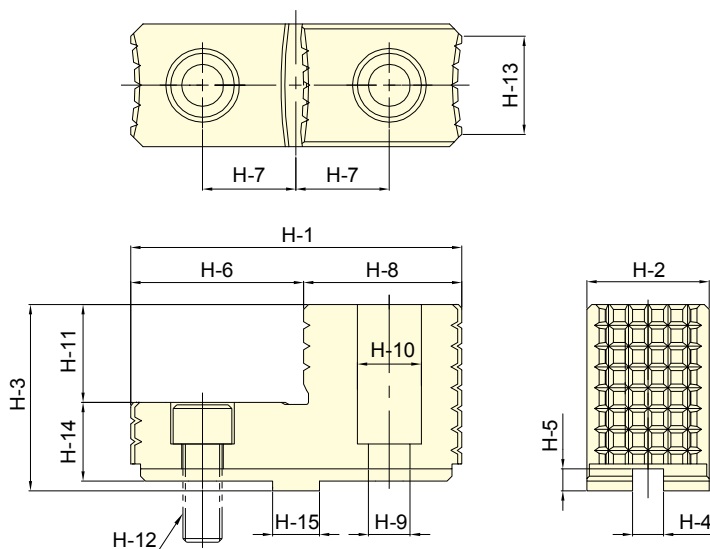

保留規格修改的權利 Subject to technical changes

外型尺寸 DIMENSIONS

型號 Model	H-1	H-2	H-3	H-4	H-5	H-6	H-7	H-8	H-9	H-10	H-11	H-12	H-13	H-14	H-15	適用夾頭	三爪重量 kg
																Matching Chuck	3 Jaw Weight
3MF-20	135	50	76	12.7	9	70	38.1	65	17	26	40	M16	40	32	19.03	3MF-20	6.7

AP 標準硬爪 STANDARD HARDEN JAW FOR AP CHUCK

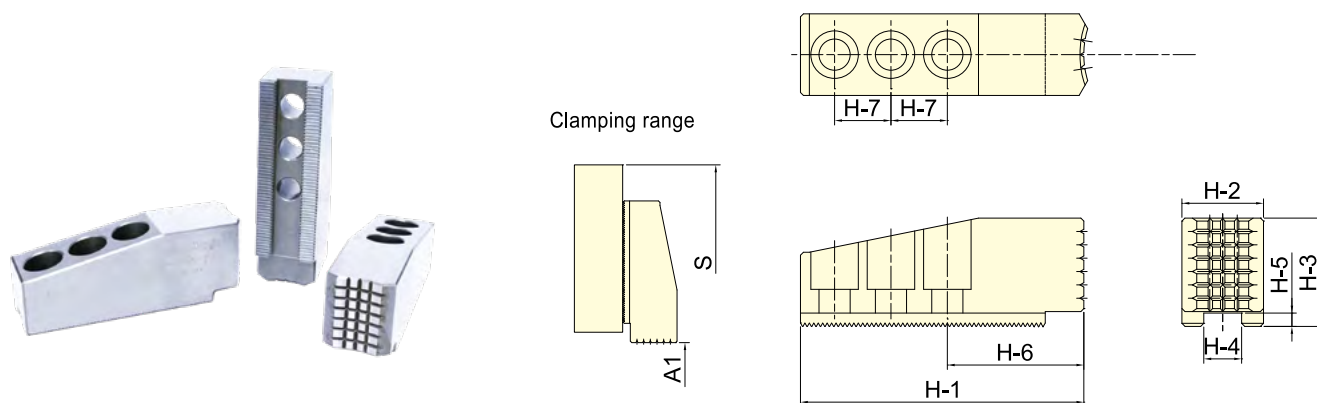

保留規格修改的權利 Subject to technical changes

外型尺寸 DIMENSIONS

型號 Model	H-1	H-2	H-3	H-4	H-5	H-6	H-7	A1	S	排齒節距 Serration Pitch	適用夾頭 Matching Chuck	三爪重量 kg 3 Jaw Weight kg
	HJ-145	191	55	73	25.5	9	92	38	30-125	420	3.0 × 60 °	AP-145
HJ-145	191	55	73	25.5	9	92	38	35-165	460	3.0 × 60 °	AP-185	12.5
HJ-145	191	55	73	25.5	9	92	38	55-240	535	3.0 × 60 °	AP-230	12.5
HJ-145	191	55	73	25.5	9	92	38	100-285	580	3.0 × 60 °	AP-275	12.5
HJ-320	243	75	82	30	9	110	50	105-300	658	3.0 × 60 °	AP-320	24.6
HJ-320	243	75	82	30	9	110	50	165-375	738	3.0 × 60 °	AP-375	24.6

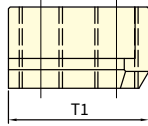
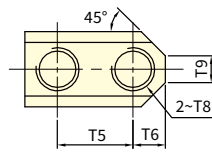
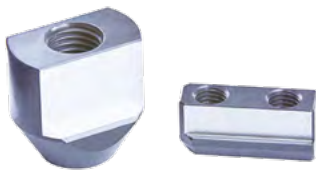

TN 1

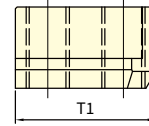
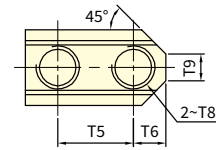
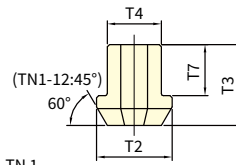

TN 2

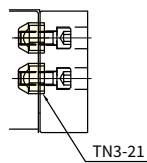
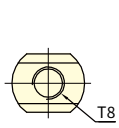
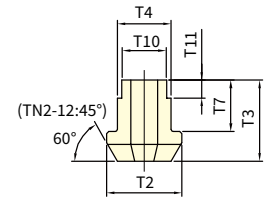

TN 3

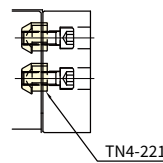
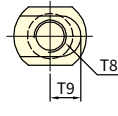

TN 4

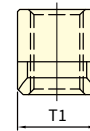
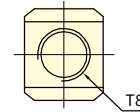

TN 5

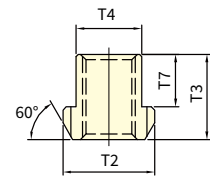

保留規格修改的權利
Subject to technical changes

外型尺寸 DIMENSIONS

型號 Model	T1	T2	T3	T4	T5	T6	T7	T8	T9	T10	T11	適合夾頭 Matching Chuck	三只重量 3 Pcs Weight
													kg
TN1-04	26	14	15	10	14	6	9.5	M8	5	-	-	H-204, H-205, P-04, P-05, L-205, M-05, SP-304	0.06
TN1-06	36	17	18.5	12	20	8	11	M10	6	-	-	H-206, P-06, L-206, 1L-06, M-06, 3N-06, AP-52, RAP-306, SP-306	0.15
TN1-08	46.5	20	20.5	14	25	10.5	12	M12	10	-	-	H-208, P-08, L-208, 1L-08, M-08, 3N-08, 4T-08, AP-66, RAP-308, SP-308	0.27
TN1-10	51	22	21.5	16	30	11	13	M12	11	-	-	H-210, P-10, L-210, 1L-10, M-10, 3N-10, 4T-10, AP-86, RAP-310, SP-310	0.36
* TN1-12	55.5	29.5	28	21	30	12	16.5	M16	13	-	-	P-12, L-12, M-12	0.63
TN2-12	55.5	29.5	28	21	30	12	16.5	M14	13	18	4.5	P-12, L-12, M-12	0.63
* TN1-15	80	35	39.5	25.5	43	17	20.5	M20	14	-	-	2H-15, 3H-18B, P-15, P-215, P-218, L-15, M-215, M-218, V-15, V-18	1.53
TN2-15	80	35	39.5	25.5	43	17	20.5	M20	14	22	6	2H-15, 3H-18B, P-15, P-215, P-218, L-15, M-215, M-218, V-15, V-18	1.5
* TN1-212	56	29.5	23.5	21	30	12	12	M16	10	-	-	H-12, H-212, L-212, V-12, 4T-15, AP-115	0.63
TN2-212	56	29.5	23.5	21	30	12	12	M14	10	18	4	H-12, H-212, L-212, V-12, 4T-15, AP-115	0.63
* TN1-215	80	35	34	25.5	43	17	19	M20	14	-	-	3H-15, 4H-15, 3H-18, 4H-18, H-215, L-215, SP-316	1.32
TN2-215	80	35	34	25.5	43	17	19	M20	14	22	6	3H-15, 4H-15, 3H-18, 4H-18, H-215, L-215, SP-316	1.29
TN3-21	46	37.5	45	25	26	-	26	M20	-	-	-	P-221, P-224, M-221, M-224, V-21, V-24, V-32,	1.84
TN4-221	45	36	38	25	28	-	22	M20	19	-	-	H-221, H-224, H-232, SP-320, SP-324	0.63
TN5-185	32	35	30	25.5	-	-	19	M20	-	-	-	AP-145, AP-185, AP-230, AP-275	0.15
TN5-320	36	42	39	30	-	-	24	M24	-	-	-	AP-320, AP-375	0.24

* TN1-12 & TN1-212 為 12" 夾頭出廠配備。(12" Chucks are originally equipped with TN1-12 & TN1-212.)

* TN1-15 & TN1-215 為 15" 夾頭出廠配備。(15" Chucks are originally equipped with TN1-15 & TN1-215.)

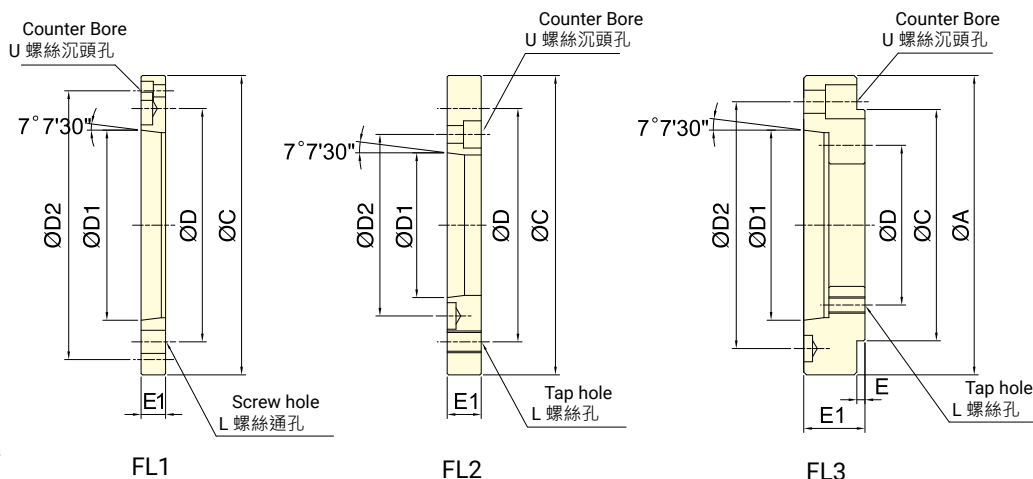

保留規格修改的權利
Subject to technical changes

外型尺寸 DIMENSIONS

Model	A	C	D	D1	D2	E	E1	L	U	備註 Remark	重量 Weight (kg)
FL3-04A \times 4	110	85	70.6	63.513	82.6	8	28	M10	M10	3H-204, 2H-204	1.12
FL3-04A \times 5	140	85	70.6	82.563	104.8	5.5	32	M10	M10	3H-204, 2H-204	2.28
FL1-05A \times 4	-	110	82.6	63.513	96	-	15	M10	M6	3H-205, 2H-205, 3L-05, 2L-05, 3J-05, 2J-05	0.65
FL3-05A \times 5	135	110	82.6	82.563	104.8	6	30	M10	M10	3H-205, 2H-205, 3L-05, 2L-05	1.99
FL1-06A \times 5	-	140	104.8	82.563	116	-	15 *18	M10	M6	2H-206, 4H-206, 3H-206, 3P-06, 2P-06, 3M-06, 2M-06, 3E-06, 3D-06, 2D-06, 3N-06, 3J-06, 2J-06 *3L-206, *2L-206	0.96
FL3-06A \times 6	165	140	104.8	106.375	133.4	6	35	M10	M12	2H-206, 4H-206, 3H-206, 3L-206, 2L-206, 3P-06, 2P-06, 3M-06, 2M-06, 3E-06, 3D-06, 2D-06, 3N-06, 3J-06, 2J-06	3.12
FL2-08A \times 5	-	170	133.4	82.563	104.8	-	23	M12	M10	3H-208, 2H-208, 4H-208, 3P-08, 2P-08, 3M-08, 2M-08, 4T-08, 3E-08, 3D-08, 2D-08, 3N-08, 3J-08, 2J-08, 3R-08, 3W-08, 3Q-08 *3L-208, *2L-208,	2.7
FL1-08A \times 6	-	170	133.4	106.375	150	-	17 *23	M12	M6	2H-208, 4H-208, 3H-208, 3P-08, 2P-08, 3M-08, 2M-08, 4T-08, 3E-08, 3D-08, 2D-08, 3N-08, 3J-08, 2J-08, 3R-08, 3W-08, 3Q-08 *3L-208, *2L-208	1.55
FL2-10A \times 6	-	220	171.4	106.375	133.4	-	25	M16	M12	4H-10, 3P-10, 2P-10, 3M-10, 2M-10, 3H-12, 2H-12, 4H-12, 3L-212, 2L-12, 3P-12, 2P-12, 3M-12, 2M-12, 4T-10, 4T-12, 3E-10, 3D-10, 2D-10, 3N-10, 3J-10, 2J-10, 3R-10, 3Q-10, 3W-10, 3W-12	5.02
FL1-10A \times 8	-	220	171.4	139.719	190	-	18	M16	M8	2H-210, 4H-10, 3H-210, 3L-210, 2L-210, 3P-10, 2P-10, 3M-10, 2M-10, 3H-12, 2H-12, 4H-12, 3L-212, 2L-12, 3P-12, 2P-12, 3M-12, 2M-12, 4T-10, 4T-12, 3E-10, 3D-10, 2D-10, 3N-10, 3J-10, 2J-10, 3R-10, 3Q-10, 3Q-12, 3W-10, 3W-12	2.73
FL2-15A \times 8	-	300	235	139.719	171.4	-	33	M20	M16	3H-15, 3H-212, 2H-15, 4H-15, 3L-15, 2L-15, 3P-215, 2P-15, 3M-15, 2M-15, 4T-15, 3H-18, 4H-18, 3P-218	12.52
FL1-15A \times 11	-	300	235	196.869	260	-	22	M20	M10	3H-15, 3H-212, 2H-15, 4H-15, 3L-15, 2L-15, 3P-215, 2P-15, 3M-15, 2M-15, 4T-15, 3H-18, 4H-18, 3P-218	6.03
FL2-21A \times 8	-	380	330.2	139.719	171.4	-	33	M24	M16	3H-215, 3P-221, 3P-224	22.05
FL2-21A \times 11	-	380	330.2	196.869	235	-	40 *27	M24	M20	3H-215 *3P-221, *3P-224	16.28
FL1-21A \times 15	-	380	330.2	285.775	330.2	-	27	M24	M12	3H-215, 3H-18B, 3H-221, 3P-221, 3P-224	8.6
FL2-40A \times 15	-	520	463.6	285.775	330.2	-	40	M24	M24	3H-224	43.26
FL1-40A \times 20	-	520	463.6	412.775	463.6	-	27	M24	M12	3H-224, 3H-232	13.55

“*” 記號表示接單生產之型號規格，無現貨供應。(Models with “*” mark are produced only by order.)



- 可附加行程確認裝置和線性檢知裝置(選配)。
- The proximity switch and linear Sensor are optional.

■ 行程確認裝置。(選配) The proximity switch is optional.

電壓	負荷容量	輸出規格
Power supply	Switching cap.	Output tpye
DC 10/30V	100mA	NPN

■ 端子連接 Terminal Connections

+V	OP1	OV
棕 BROWN	黑 BLACK	藍 BLUE

■ 線性檢知裝置安裝示意圖
linear Sensor installation drawing

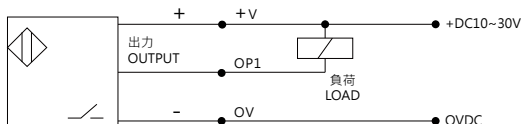
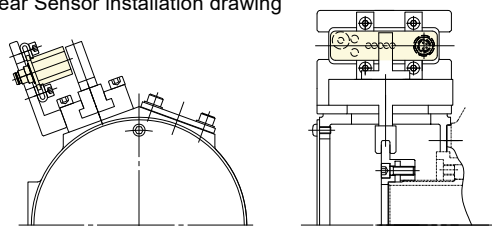

CT

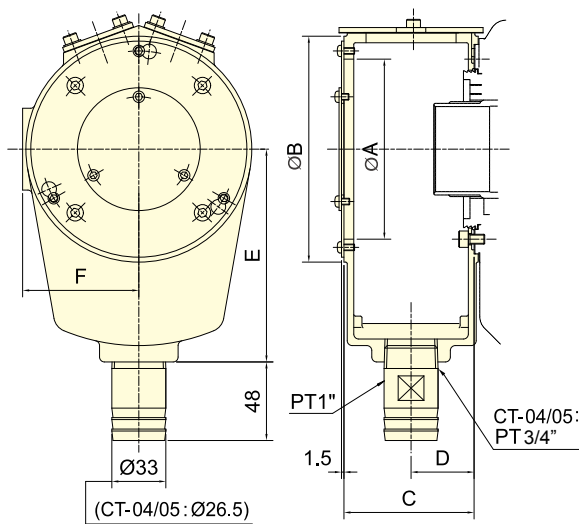

(CT-04/05 : Ø26.5)
(CT-24/28 : Ø60)

集水盒
Coolant Collector

CT-S

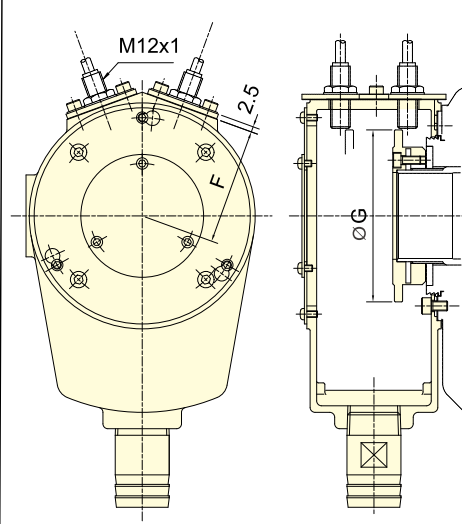

集水盒與檢出環
Coolant Collector with Detecting Ring

保留規格修改的權利
Subject to technical changes

外型尺寸 DIMENSIONS

Model	A	B	C	D	E	F	G	重量Weight (kg)		適用迴轉缸
								CT	CT-S	Matching cyl.
CT-04/CT-04S	87	110	60	29	110	57	79	0.9	1.1	TH-428
CT-05/CT-05S(TH)	87	110	60	29	110	57	84	0.9	1.1	TH-A536
CT-05/CT-05S(TK)	87	110	60	29	110	57	84	0.9	1.1	TK-A528, TK-A533
CT-06/CT-06S	100	125	74	36	120	64.5	94	1.2	1.6	TK-C643, TK-A646, TK-B646, TK-C646, TR-646
CT-08/CT-08S	110	138	80	39	130	71	105	1.3	1.8	TK-B846, TK-A853, TK-B853, TR-853
CT-K10/CT-K10S	158	185	88	43	160	94.5	145	1.9	2.6	TK-A1068, TK-A1075, TK-A1078, TR-1075
CT-12/CT-12S	158	185	88	43	160	94.5	145	1.9	2.6	TK-A1287, TK-A1291, TR-1291
CT-15/CT-15S	206	235	100	50	210	121	190	3.1	4.3	TK-A1511, TK-A1512, TK-A1512-35
CT-21/CT-21S	226	255	100	50	210	131	210	3.3	4.6	TK-2114
CT-24/CT-24S	250	270	100	50	230	154	248	3.5	5.5	TK-2416, TK-2416L
CT-28/CT-28S	310	330	100	50	260	181	305	4.3	7.2	TK-2820



- 可附加行程確認裝置和線性檢知裝置(選配)。
 - 加大的排水管接頭Ø40和Ø60(選購品)。
 - Ø60排水管接頭只適用於CT-S08B、CT-S10B、CT-S12B。
 - The proximity switch and linear Sensor are optional.
 - Drain port Ø40 and Ø60 are optional product.
 - Drain port Ø60 only use to CT-S08B,CT-S10B,CT-S12B.
- 行程確認裝置。(選配) The proximity switch is optional.

電壓	負荷容量	輸出規格
Power supply	Switching cap.	Output type
DC 10/30V	100mA	NPN

■ 端子連接 Terminal Connections

+V	OP1	OV
棕 BROWN	黑 BLACK	藍 BLUE

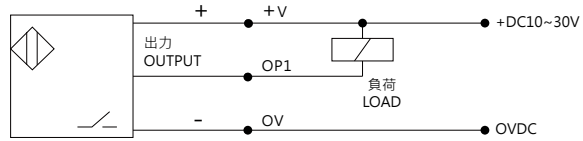

■ 線性檢知裝置安裝示意圖
linear Sensor installation drawing

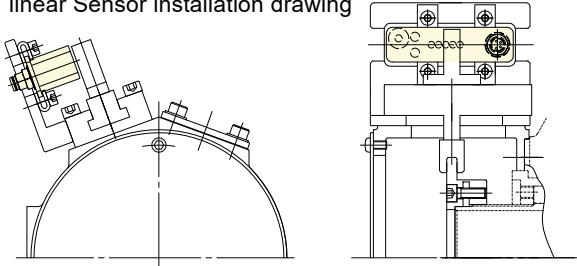

零附件與其他

CT-SB

CT-SBS

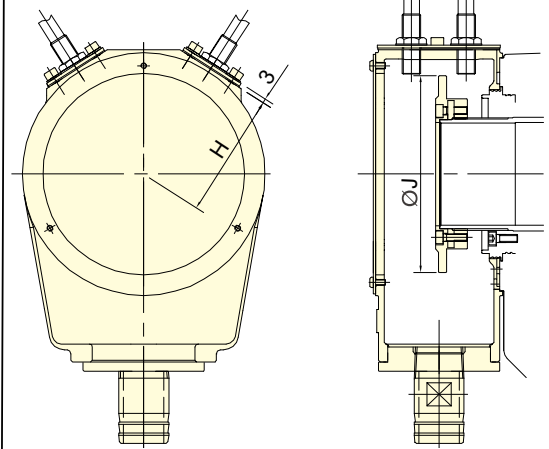
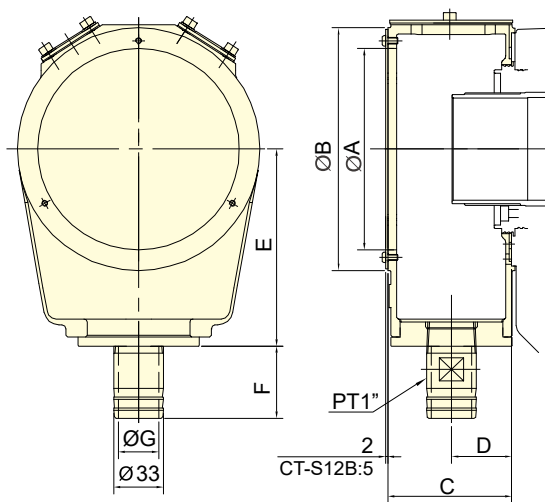
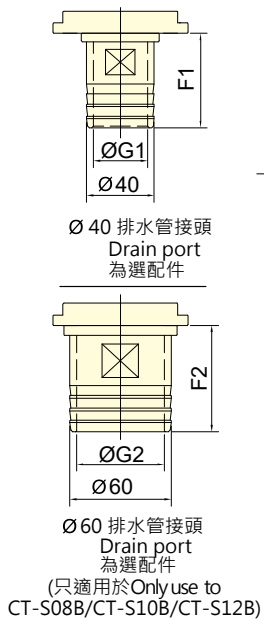

保留規格修改的權利
Subject to technical changes

外型尺寸 DIMENSIONS

Model	A	B	C	D	E	F	F1	F2	G	G1	G2	H	J	重量Weight (kg)		適用迴轉缸
														CT-SB	CT-SBS	Matching cyl.
CT-S05B/CT-S05BS	97	120	68.3	33.3	96	49.6	56	-	25	32	-	62	86	1.1	1.6	TS-539, TR-539
CT-S08B/CT-S08BS	133	160	82	40	130	49.6	56	63	25	32	52	82	130	0.9	1.4	TS-866
CT-S10B/CT-S10BS	160	188	88	43	148	49.6	56	63	25	32	52	96	148	1.16	2.9	TS-1081
CT-S12B/CT-S12BS	205	234	87	43.5	171	49.6	56	63	25	32	52	121	190	4.3	5.6	TS-1210

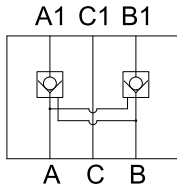
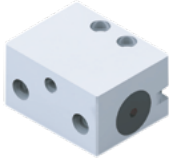

Circuit drawing
迴路圖

Model:FV-01

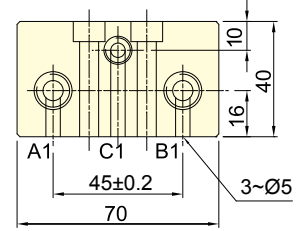
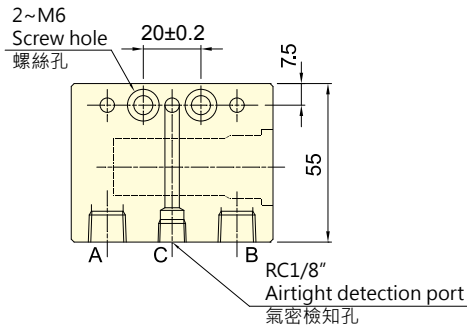

Model:FV-03

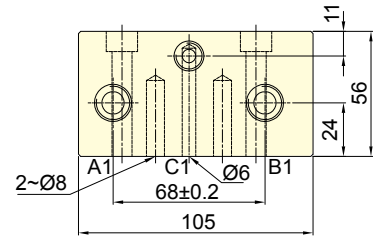
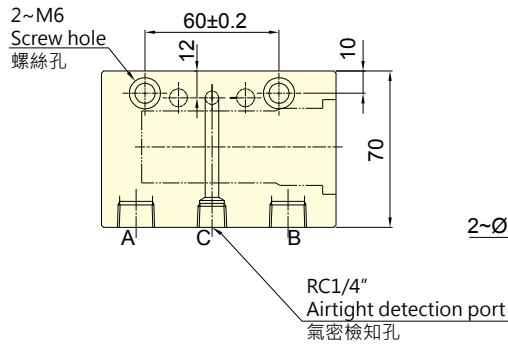

保留規格修改的權利
Subject to technical changes

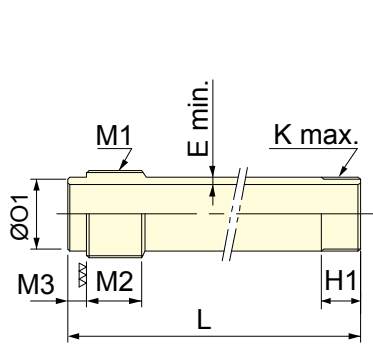

中空拉桿詳圖 Detail of Draw Tube

$$L = A + G2_{max.} + H - G1_{max.} + M2 + M3$$

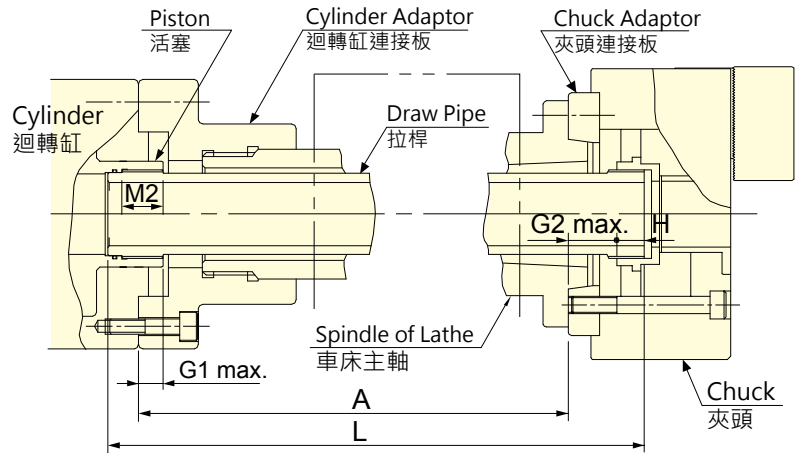

零附件與其他

保留規格修改的權利
Subject to technical changes

技術規格 SPECIFICATIONS

夾頭規格		迴轉缸規格	G1 max.	H	M3	M2	G2 max.	M1	H1	O1		K max.	E min.	L
Chuck type	Cylinder type	(f7)												
3H-12	A8	TK-A1291	30	23	12	35	28	M100x2	35	95	-0.036 -0.071	M100x2	5	A+56+12
3H-15	A11	TK-A1512	30	33	12	45	33	M130x2	45	125	-0.043 -0.083	M130x2	5	A+81+12
3H-18	A11	TK-A1512	30	33	12	45	33	M130x2	45	125	-0.043 -0.083	M130x2	5	A+81+12

夾頭規格		迴轉缸規格	G1 max.	H	M3	M2	G2 max.	M1	H1	O1		K max.	E min.	L
Chuck type	Cylinder type	(f7)												
3H-204	A4	TK-A528	12	14.5	10	25	31.5	M38x1.5	20	35	-0.025 -0.05	M38x1.5	5	A+59+10
3H-205	A4	TK-A533	12	17	10	25	16	M38x1.5	25	35	-0.025 -0.05	M45x1.5	5	A+46+10
3H-206	A5	TK-A646	15	14	10	25	28	M55x2	20	50	-0.025 -0.05	M60x2	5	A+52+10
3H-208	A6	TK-A853	20	16.5	12	30	33.5	M60x2	20	55	-0.03 -0.06	M75x2	5	A+60+12
3H-210	A8	TK-A1075	25	21	12	35	28.5	M85x2	25	80	-0.03 -0.06	M95x2	5	A+59.5+12
3H-212	A11	TK-A1512	30	23	12	45	32	M130x2	30	125	-0.043 -0.083	M115x2	5	A+70+12
3H-215	A8	TK-2114	35	33	17	45	44	M155x2	40	145	-0.043 -0.083	M115x2	5	A+87+17
3H-215	A11	TK-2114	35	33	17	45	51	M155x2	40	145	-0.043 -0.083	M155x3	5	A+93+17
3H-215	A15	TK-2114	35	33	17	45	38	M155x2	40	145	-0.043 -0.083	M155x3	5	A+81+17
3H-18B	A15	TK-2416	35	35	17	45	45	M180x3	40	170	-0.043 -0.083	M175x3	5	A+90+17
3H-221	A15	TK-2416	35	34	17	45	42	M180x3	40	170	-0.043 -0.083	M190x3	5	A+86+17
3H-224	A20	TK-2820	51	35	17	45	42	M220x3	40	210	-0.050 -0.096	M225x3	5	A+71+17
3H-232	A20	TK-2820	51	37	17	45	51	M220x3	45	230	-0.050 -0.096	M295x3	5	A+82+17

註：2H,4H 型式之拉桿長度計算同 3H、3H-2 型式。(Note: To calculate the draw-tube length of 2H,4H as 3H,3H-2.)

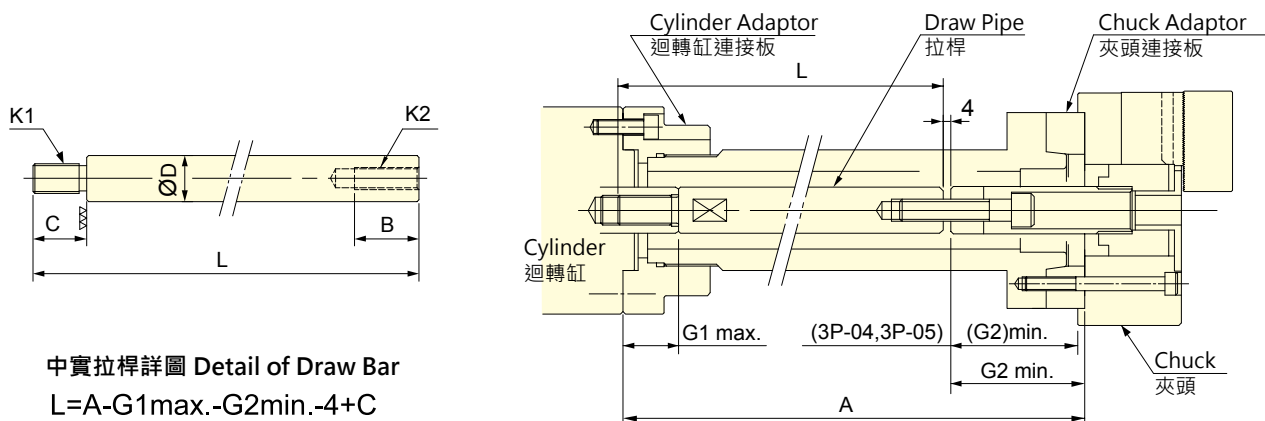

保留規格修改的權利
Subject to technical changes

技術規格 SPECIFICATIONS

夾頭型式 Chuck type	迴轉缸型式 Cylinder type	B	C	D	G1 max.	G2 min.	K1	K2	L
3P-04	RK-75(N)/RA-130	30	30/20	30/25	45	3	M20x2.5/M16x2	M10x1.5	A-22/A-32
3P-05	RK-75(N)/RA-130	40	30/20	30/25	45	-6	M20x2.5/M16x2	M12x1.75	A-13/A-23
3P-06	RK-100(N)/RA-170	40	30/25	30/25	45	81.5	M20x2.5/M16x2	M16x2	A-101/A-106
3P-08	RK-125(N)/RA-220	40	40/30	35/30	50	106	M24x3/M20x2.5	M20x2.5	A-120/A-130
3P-10	RK-125(N)/RA-220	40	40/30	35/30	50	133	M24x3/M20x2.5	M20x2.5	A-147/A-157
3P-12	RK-150(N)/RA-270	40	40/35	45/35	55	133	M30x3.5/M24x3	M20x2.5	A-152/A-157
3P-215	RK-200(N)/RH-200	60	55	55	70	69	M36x4	M30x3.5	A-88
3P-218	RK-200(N)/RH-200	60	55	55	70	57	M36x4	M30x3.5	A-76
3P-221	RK-200(N)/RH-200	60	55	55	70	62	M36x4	M30x3.5	A-81
3P-224	RK-200(N)/RH-200	60	55	55	70	62	M36x4	M30x3.5	A-81

註 :2P 型式之拉桿長度計算同 3P 型式。(Note: To calculate the draw-bar length of 2P as 3P.)

夾頭型式 Chuck type	迴轉缸型式 Cylinder type	B	C	D	G1 max.	G2 min.	K1	K2	L
3M-05	RK-75(N)	40	30	30	45	-2	M20x2.5	M12x1.75	A-17
3M-06	RK-100(N)	40	30	30	45	81.5	M20x2.5	M16x2	A-101
3M-08	RK-125(N)	40	40	35	50	106	M24x3.0	M20x2.5	A-120
3M-10	RK-150(N)	40	40	35	50	135	M24x3.0	M20x2.5	A-148
3M-12	RK-150(N)	50	40	45	55	40	M30x3.5	M24x3	A-59

註 :2M 型式之拉桿長度計算同 3M 型式。(Note: To calculate the draw-bar length of 2M as 3M.)







追蹤AUTOGRIP 即刻掌握最新訊息!
FOLLOW AUTOGRIP AND STAY UPDATED WITH THE LATEST NEWS!



*2D圖檔(PDF、DWG格式)、3D圖檔(STEP格式) 可以從官網下載。

*You can download the outline drawing (in pdf or dwg format) and 3D step at AUTOGRIP WEB.