

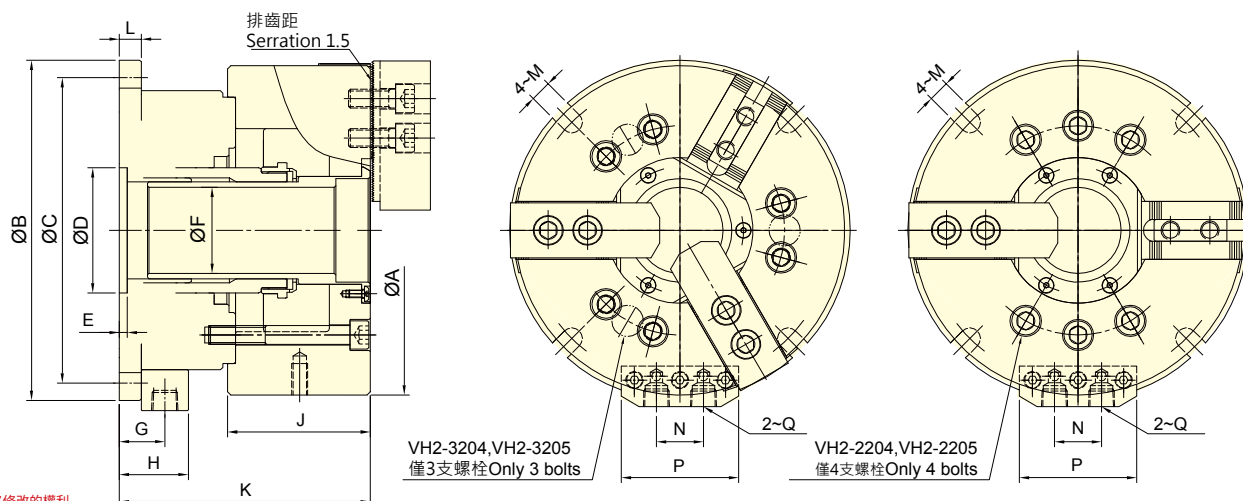

- 立置式中空動力夾頭，適合鑽床、銑床或切削中心機使用，有二爪及三爪兩種形式。
- VH2-2200型式所配對之夾頭規格及寸法與2H-2型式相同。
- VH2-3200型式所配對之夾頭規格及寸法與3H-2型式相同。
- Stationary Chuck with two or three jaws for drilling, milling and other machines.
- Specification and size of matching chuck for model VH2-2200 is the same as model 2H-2.
- Specification and size of matching chuck for model VH2-3200 is the same as model 3H-2.



保留規格修改的權利
Subject to technical changes

技術規格 SPECIFICATIONS

型號 Model	活塞面積Eff. Piston area		爪行程(直徑) Jaw stroke(Dia.) mm	最大使用壓力 Max. pressure MPa(kgf/cm ²)	重量 Weight kg
	押側Extend cm ²	拉側Retract cm ²			
VH2-2204	52.4	46.7	5.5	2.0 (20)	9.5
VH2-3204	52.4	46.7	5.5	3.0 (30)	9.5
VH2-2205	63.7	57.9	5.5	2.0 (20)	13.1
VH2-3205	63.7	57.9	5.5	3.0 (30)	12.6
VH2-2206	97.1	88.5	6.0	1.8 (17.9)	21.5
VH2-3206	97.1	88.5	6.0	2.7 (26.8)	21.5
VH2-2208	128.9	113.6	7.6	2.1 (20.7)	32.9
VH2-3208	128.9	113.6	7.6	2.9 (28.6)	33.4
VH2-2210	189.2	174.3	8.9	1.9 (19.2)	55
VH2-3210	189.2	174.3	8.9	2.9 (28.7)	59

外型尺寸 DIMENSIONS

Model	A	B	C	D(H7)	E	F	G	H	J	K	L	M	N	P	Q
VH2-2204	113	155	137	50	5	27	23	34	59	122.5	12	9	26	62	RC1/4
VH2-3204	113	155	137	50	5	27	23	34	59	122.5	12	9	26	62	RC1/4
VH2-2205	138	168	150	60	5	32	23	34	60	125	12	9	26	62	RC1/4
VH2-3205	138	168	150	60	5	32	23	34	60	125	12	9	26	62	RC1/4
VH2-2206	170	194	176	80	5	45	25	36	81	143	14	11	26	62	RC1/4
VH2-3206	170	194	176	80	5	45	25	36	81	143	14	11	26	62	RC1/4
VH2-2208	210	217	195	80	5	55	29	44	91	160	14	13.5	30	75	RC3/8
VH2-3208	210	217	195	80	5	55	29	44	91	160	14	13.5	30	75	RC3/8
VH2-2210	260	266	246	100	6	76	32	47	102	192	17	13.5	30	75	RC3/8
VH2-3210	260	266	246	100	6	76	32	47	102	192	17	13.5	30	75	RC3/8



- 立置式中實動力夾頭，適合鑽床、銑床或切削中心機使用，有二爪及三爪兩種形式。
- VP-200型式所配對之夾頭規格及寸法與2P型式相同。
- VP-300型式所配對之夾頭規格及寸法與3P型式相同。
- Stationary Chuck with two or three jaws for drilling, milling and other machines.
- Specification and size of matching chuck for model VP-200 is the same as model 2P.
- Specification and size of matching chuck for model VP-300 is the same as model 3P.

立置式夾頭

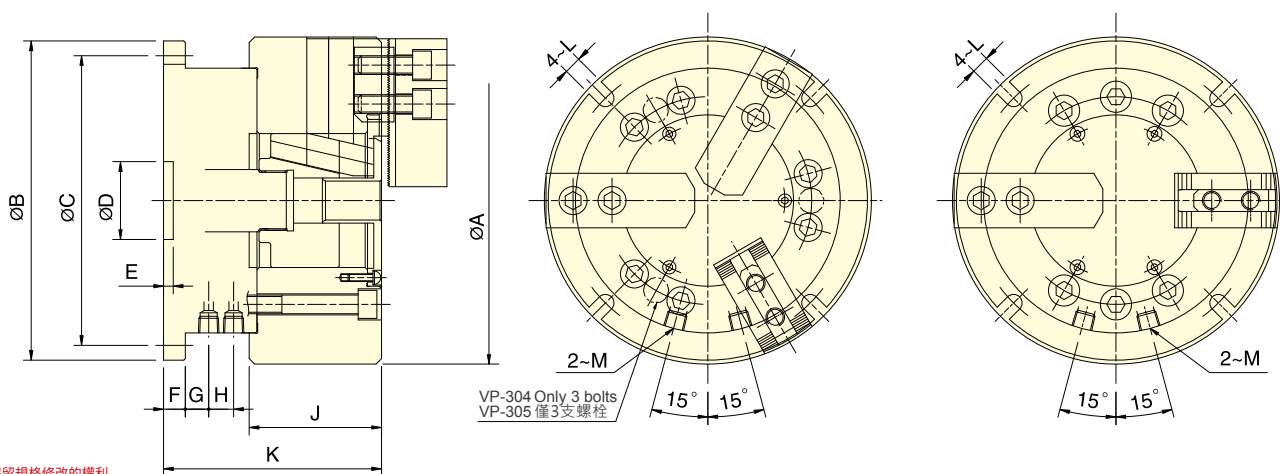

保留規格修改的權利
Subject to technical changes

技術規格 SPECIFICATIONS

型號 Model	活塞面積Eff. Piston area		爪行程(直徑) Jaw stroke(Dia.)	最大使用壓力 Max. pressure	重量 Weight
	伸側Extend cm ²	拉側Retract cm ²	mm	MPa(kgf/cm ²)	kg
VP-204	28.0	24.9	6.4	2.1(21)	7.1
VP-304	28.0	24.9	6.4	3.2(32)	7.4
VP-205	28.0	24.9	6.4	2.2(22)	10.2
VP-305	28.0	24.9	6.4	3.3(33)	10.6
VP-206	63.1	53.5	8.5	2.3(23)	18.3
VP-306	63.1	53.5	8.5	3.4(34)	19.8
VP-208	103.4	90.8	8.8	1.9(19)	31.6
VP-308	103.4	90.8	8.8	2.8(28)	33.6
VP-210	153.1	133.5	8.8	1.5(15)	52.8
VP-310	153.1	133.5	8.8	2.2(22)	54.5

外型尺寸 DIMENSIONS

Model	A	B	C	D(H8)	E	F	G	H	J	K	L	M
VP-204	110	146	130	30	4.5	12	18	2	52	92	9	RC1/4
VP-304	110	146	130	30	4.5	12	18	2	52	92	9	RC1/4
VP-205	135	146	130	30	4.5	12	18	2	55	95	9	RC1/4
VP-305	135	146	130	30	4.5	12	18	2	55	95	9	RC1/4
VP-206	165	178	160	40	5	12	14.5	12.5	74	125	11	RC1/4
VP-306	165	178	160	40	5	12	14.5	12.5	74	125	11	RC1/4
VP-208	210	205	186	40	5	14	15	16	85	140	11	RC1/4
VP-308	210	205	186	40	5	14	15	16	85	140	11	RC1/4
VP-210	254	248	225	50	6	17	20	18	89	176	13	RC3/8
VP-310	254	248	225	50	6	17	20	18	89	176	13	RC3/8



- 立置式中實夾頭和立置式中空夾頭，有二爪及三爪兩種夾爪形式。
- 內建油壓缸，亦可選配保壓閥，支援氣壓驅動。
- 小通孔設計，適合加工較長棒材。
- 安裝簡便，接上配管即可開始作業。
- 輕薄設計，可搭配標準生爪或硬爪使用。
- 可結合立置夾頭座板進行多樣化加工應用。
- 適用於旋轉加工，可安裝於車銑複合加工機。
- Stationary Chucks – Non-Thru-Hole and Thru-Hole Types.
- Available in two jaw configurations: 2-jaw and 3-jaw.
- Equipped with a built-in hydraulic cylinder; compatible with lock valves and can also be operated using air pressure.
- Features a small thru-hole, making it ideal for machining long bar workpieces.
- Side and bottom air/hydraulic inlets available; either can be used for operation.
- Slim and compact design. Compatible with standard soft jaws or hard jaws.
- Suitable for rotary machining and can be installed on mill-turn machines.
- Can be integrated with multi-plate setups for enhanced versatility.

立置式夾頭

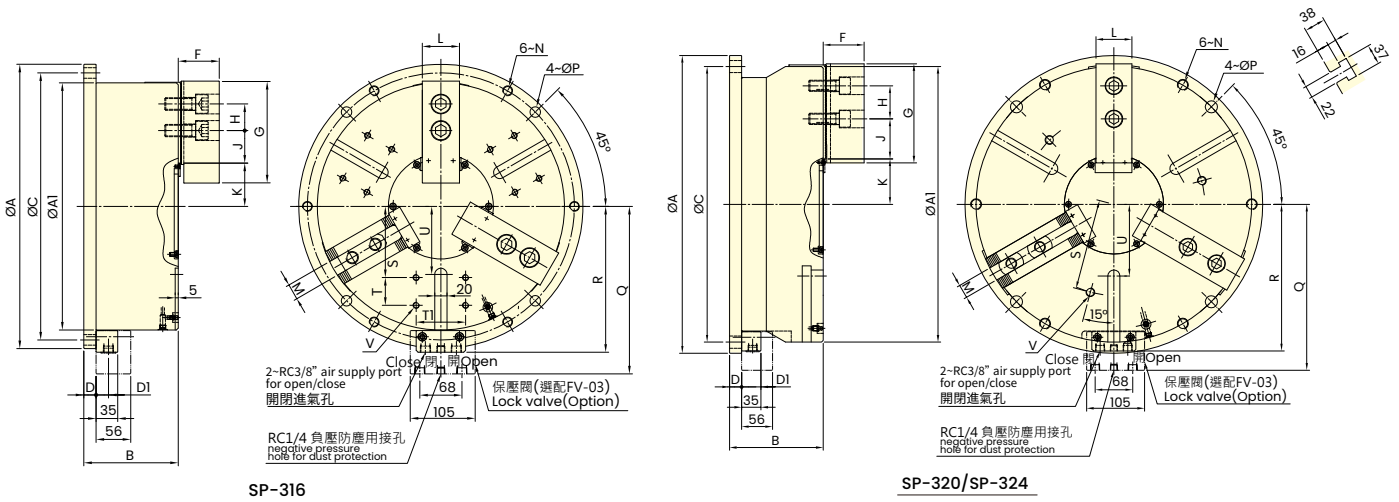
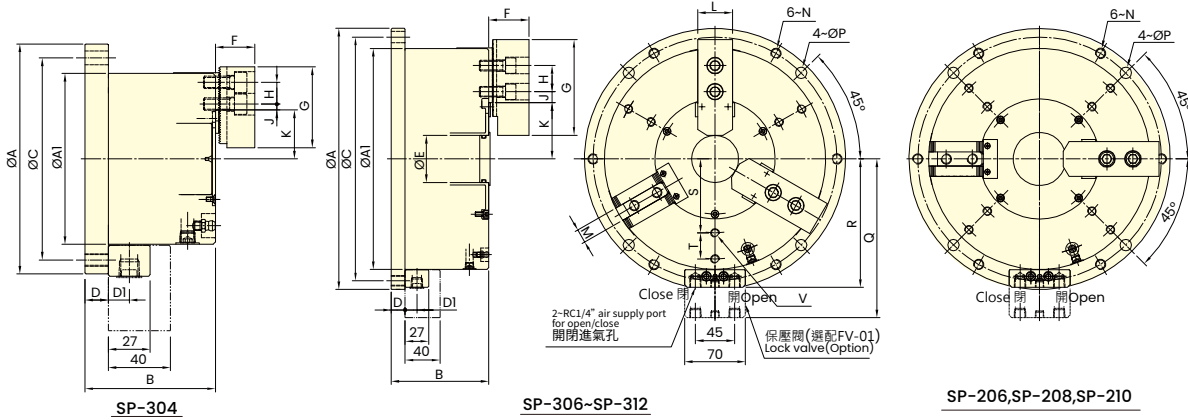

保留規格修改的權利
Subject to technical changes

技術規格 SPECIFICATIONS

型號	爪行程 (直徑)	夾持直徑		最大夾持力		最大使用壓力		最低使用壓力	空氣消耗量 使用壓力6.0 kgf/cm ²	重量
		最大	最小	氣壓	油壓	氣壓	油壓			
Model	Jaw stroke (Dia.)	Chucking Dia.		Max. clamping force		Max. pressure		Min. pressure	Air consumption	Weight
		Max.	Min.	Pneumatic	Hydraulic	Pneumatic	Hydraulic			
	mm	mm	mm	kN(kgf)	kN(kgf)	MPa(kgf/cm ²)	MPa(kgf/cm ²)	kgf/cm ²	lit (at 6.0 kgf/cm ²)	kg
SP-304	5.1	110	10	7.5(765)	22.0(2243)	0.7(7)	1.2(12)	2	0.5	7
SP-206	5.5	168	30	34.1(3477)	46.1(4752)	0.7(7)	1.2(12)	2	1.4	16
SP-306	5.5	168	30	35.5(3620)	60.0(5252)	0.7(7)	1.2(12)	2	1.4	16.5
SP-208	6.8	210	42	43.2(4405)	74.0(7545)	0.7(7)	1.2(12)	2	2.5	27.7
SP-308	6.8	210	42	51.5(5251)	88.3(9004)	0.7(7)	1.2(12)	2	2.5	28.7

型號	爪行程 (直徑)	夾持直徑		最大夾持力		最大使用壓力		最低使用壓力	空氣消耗量	重量
		最大	最小	氣壓	油壓	氣壓	油壓		使用壓力6.0 kgf/cm ²	
		Model	Jaw stroke (Dia.)	Chucking Dia.		Max. clamping force			Max. pressure	
	mm	mm	mm	Pneumatic kN(kgf)	Hydraulic kN(kgf)	Pneumatic MPa(kgf/cm ²)	Hydraulic MPa(kgf/cm ²)	kgf/cm ²	lit (at 6.0 kgf/cm ²)	kg
SP-210	7	254	52	60.5(6169)	94.5(9636)	0.7(7)	1.2(12)	2	4.2	41.8
SP-310	7	254	52	68.2(6955)	118.7(12104)	0.7(7)	1.2(12)	2	4.2	42
SP-312	9.3	304	60	75.8(7729)	148 (15091)	0.7(7)	1.2(12)	2	6.4	71.3
SP-316	14.5	400	30	120.7(12305)	120.7(12305)	0.7(7)	0.7(7)	2	10.6	147.8
SP-320	16	500	45	155.6(15865)	155.6(15865)	0.7(7)	0.7(7)	2	15	232.7
SP-324	16	600	140	215.9(22015)	215.9(22015)	0.7(7)	0.7(7)	2	22	338.7

外型尺寸 DIMENSIONS

Model	A(h7)	A1	B	C	D	D1	E	F	G	H	J max.	J min.
SP-304	148	110	84	130	15	13.5	-	25	52	14	3.75	0.75
SP-206	206	168	94	188	15	13.5	25	40	73	20	10.75	4.75
SP-306	206	168	94	188	15	13.5	25	40	73	20	10.75	4.75
SP-208	248	210	108	230	15	13.5	32	41	95	25	16.25	8.75
SP-308	248	210	108	230	15	13.5	32	41	95	25	16.25	8.75
SP-210	300	254	112	280	16	13.5	54	46	110	30	23.25	12.75
SP-310	300	254	112	280	16	13.5	54	46	110	30	23.25	12.75
SP-312	350	304	130	330	18	13.5	65	54	130	30	30.75	12.75
SP-316	460	400	153	432	20	20	-	66	165	43	67.75	18.25
SP-320	540	500	170	500	22	20	-	74	180	60	87.5	24.5
SP-324	640	600	175	600	24	20	-	74	180	60	87.5	24.5

Model	K max.	K min.	L	M	N	P	Q	R	S	T	T1	U	V
SP-304	31.5	28.95	23	10	M8x1.25	9	110.5	75.5	-	-	-	-	-
SP-206	47	44.25	31	12	M10x1.5	11	139.5	104.5	55	18	-	-	6~M8x1.25
SP-306	47	44.25	31	12	M10x1.5	11	139.5	104.5	55	18	-	-	6~M8x1.25
SP-208	53	49.6	35	14	M10x1.5	11	160.5	125.5	68	25	-	-	6~M8x1.25
SP-308	53	49.6	35	14	M10x1.5	11	160.5	125.5	68	25	-	-	6~M8x1.25
SP-210	64.5	61	40	16	M12x1.75	13	182.5	147.5	85	30	-	-	6~M10x1.5
SP-310	64.5	61	40	16	M12x1.75	13	182.5	147.5	85	30	-	-	6~M10x1.5
SP-312	77.5	72.85	50	21	M12x1.75	13	207.5	172.5	100	35	-	-	6~M10x1.5
SP-316	70	62.75	60	25.5	M16x2.0	17.5	271	236	115	45	80	110	12~M10x1.5
SP-320	82.5	74.5	64	25	M20x2.5	22	301	266	165	-	-	130	3~M16x2.0
SP-324	129.5	121.5	64	25	M20x2.5	22	351	316	200	-	-	180	3~M16x2.0



- 楔形中實夾頭，長爪行程。
- 內建油壓缸，當使用氣壓做為動力源時，可選配保壓閥組件。
- 安裝容易，接上配管即可進行加工。
- 薄型輕量化設計，並可使用標準生爪或標準硬爪。
- 單一潤滑油孔，集中潤滑。
- Wedge-hook type solid power chuck with long jaw stroke.
- Equipped with a built-in hydraulic cylinder. When using air pressure as the power source, an optional pressure-holding valve can be installed.
- Easy installation — simply connect the piping and start machining.
- Thin and lightweight design, compatible with standard soft jaws or standard hard jaws.
- Features a single lubrication port for centralized lubrication.

立置式夾頭

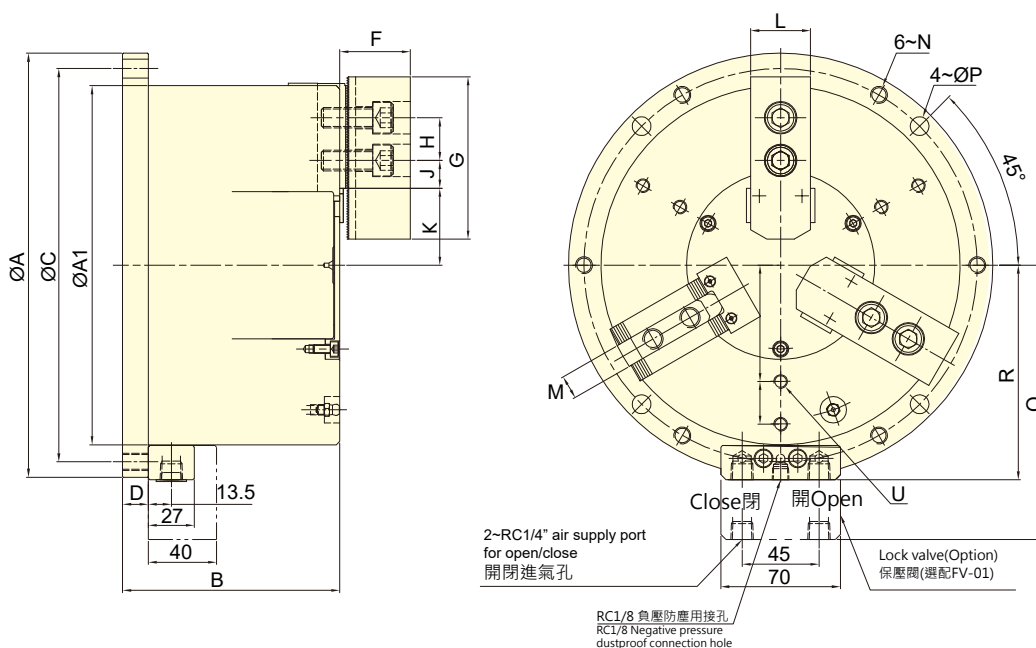

保留規格修改的權利
Subject to technical changes

技術規格 SPECIFICATIONS

型號	爪行程 (直徑)	夾持直徑		最大夾持力		最大使用壓力		最低使用壓力	空氣消耗量 使用壓力6.0 kgf/cm ²	重量
		最大	最小	氣壓	油壓	氣壓	油壓			
		Max.	Min.	Pneumatic	Hydraulic	Pneumatic	Hydraulic	Min. pressure	Air consumption	Weight
Model	Jaw stroke (Dia.)	Max.	Min.	Pneumatic	Hydraulic	Pneumatic	Hydraulic	Min. pressure	Air consumption	Weight
	mm	mm	mm	kN(kgf)	kN(kgf)	MPa(kgf/cm ²)	MPa(kgf/cm ²)	kgf/cm ²	lit (at 6.0 kgf/cm ²)	kg
SM-306	13.1	168	14	18.0(1830)	32.2(3280)	0.7(7)	1.2(12)	2	1.5	18.7
SM-308	16	210	18	26.2(2670)	45.0(4590)	0.7(7)	1.2(12)	2	2.7	32.5
SM-310	19.6	254	20	37.0(3772)	63.0(6422)	0.7(7)	1.2(12)	2	4.6	53.6

外型尺寸 DIMENSIONS

Model	A(h7)	A1	B	C	D	F	G	H	J max.	J min.
SM-306	206	168	110	188	15	40	73	20	16.75	4.75
SM-308	248	210	127	230	15	41	95	25	23.75	8.75
SM-310	300	254	145	280	16	46	110	30	36.75	14.25

Model	K max.	K min.	L	M	N	P	Q	R	S	T
SM-306	39	32.45	31	12	M10x1.5	11	139.5	104.5	55	18
SM-308	45	37	35	14	M10x1.5	11	160.5	125.5	68	25
SM-310	50	40.2	40	16	M12x1.75	13	182.5	147.5	85	30



- 內建油壓缸，當使用氣壓做為動力源時，可選配保壓閥組件。
- 可同時將工件做徑向夾持與軸向後拉，使工件不上浮並緊貼座金基準面。
- 高剛性硬化處理的本體與圓柱後拉機構，並經過軸孔精搪，確保高夾持精度與耐用度，適合重切削場合。
- 可與立置夾頭座板組合進行加工。
- Build-in hydraulic cylinder; it can also work with lock valve and be driven by air pressure.
- Radial clamp and axial pull down at the same time, keep the workpiece attaching close to the base surface of the chuck.
- Almost no workpiece uplifting displacement.
- The body with heat treatment and the organization of cylinder pull-down and fine boring, which guarantee to the high clamping precision and durability, it's suitable for heavy duty machining.
- Can work together with multi-plate.
- 配備氣密檢知。
- Equipped with Airtight pressure detection function.

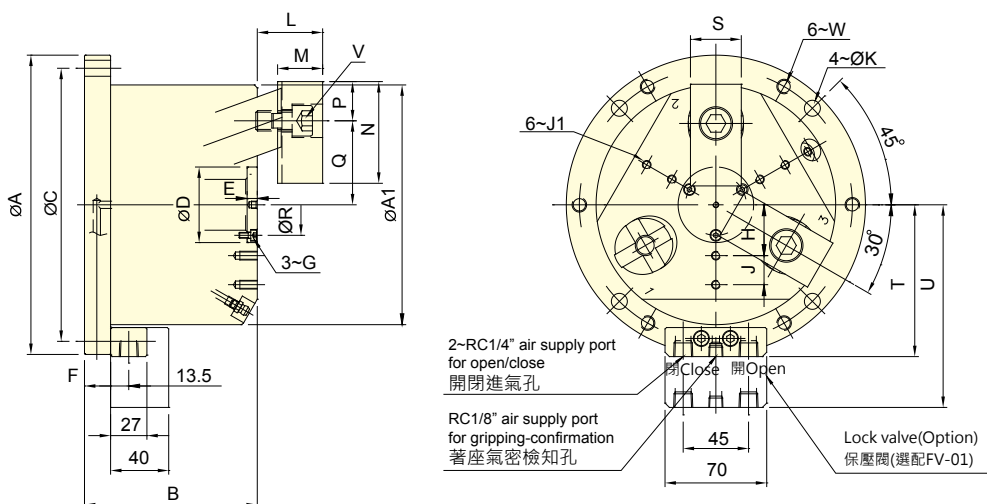

保留規格修改的權利
Subject to technical changes

技術規格 SPECIFICATIONS

型號	爪行程 (直徑)	夾持直徑		最大夾持力		最大使用壓力		最低使用壓力	空氣消耗量	重量
		最大	最小	氣壓	油壓	氣壓	油壓		使用壓力6.0 kgf/cm ²	
Model	Jaw stroke (Dia.)	Chucking Dia.		Max. clamping force		Max. pressure		Min. pressure	Air consumption	Weight
		Max.	Min.	Pneumatic	Hydraulic	Pneumatic	Hydraulic			
	mm	mm	mm	kN(kgf)	kN(kgf)	MPa(kgf/cm ²)	MPa(kgf/cm ²)	kgf/cm ²	lit (at 6.0 kgf/cm ²)	kg
SD-304	5	110	18	5.0 (510)	10.9 (1112)	0.6 (6)	1.3 (13)	2	0.26	8.1
SD-306	7.2	165	35	11.5 (1173)	25.0 (2550)	0.6 (6)	1.3 (13)	2	0.58	20.6
SD-308	7.2	210	28	21.7 (2213)	47.0 (4793)	0.6 (6)	1.3 (13)	2	1.02	34.1
SD-310	10.8	254	40	36.0(3680)	60.0(6118)	0.6 (6)	1.0 (10)	2	2.05	55

外型尺寸 DIMENSIONS

Model	A(h7)	A1	B	C	D(H7/h7)	E	F	G	H	J	J1	K	L max.	L min.
SD-304	148	110	93.5	130	35	2	15	M3	22.5	10	M5x0.8	9	30	23
SD-306	206	165	116	188	52	7	18	M4	35	20	M6x1	11	45	35
SD-308	248	210	122	230	65	10	18	M5	45	25	M8x1.2	11	56	46
SD-310	300	254	151	280	75	12	20	M6	55	30	M8x1.2	13	65	50

Model	M	N	P	Q max.	Q min.	R	S	T	U	V	W
SD-304	19.5	52	19	37	34.5	27	25	75.5	110.5	3~M10	M8x1.25
SD-306	31	70	27	57.8	54.2	42	35	104.5	139.5	3~M14	M10x1.5
SD-308	41	84	31	70.8	67.2	53	40	125.5	160.5	6~M12	M10x1.5
SD-310	46	100	38	85	79.6	62	50	147.5	182.5	6~M14	M12x1.75



- 內建油壓缸，當使用氣壓做為動力源時，可選配保壓閥組件。
- 立置式夾頭可同時將工件做徑向夾持與軸向後拉，使工件不上浮並緊貼座金基準面。適合鑽床、銑床或切削中心機使用。
- 高剛性硬化處理的本體與圓柱後拉機構，並經過軸孔精搪，確保高夾持精度與耐用度，適合重切削場合。
- 可與立置夾頭座板組合進行加工。
- Build-in hydraulic cylinder; it can also work with lock valve and be driven by air pressure.
- Radial clamp and axial pull down at the same time, keep the workpiece attaching close to the base surface of the chuck.
- Almost no workpiece uplifting displacement.
- Suitable for drilling, milling and other machines.
- The body with heat treatment and the organization of cylinder pull-down and fine boring, which guarantee to the high clamping precision and durability, it's suitable for heavy duty machining.
- Can work together with multi-plate.
- 配備氣密檢知。
- Equipped with Airtight pressure detection function.

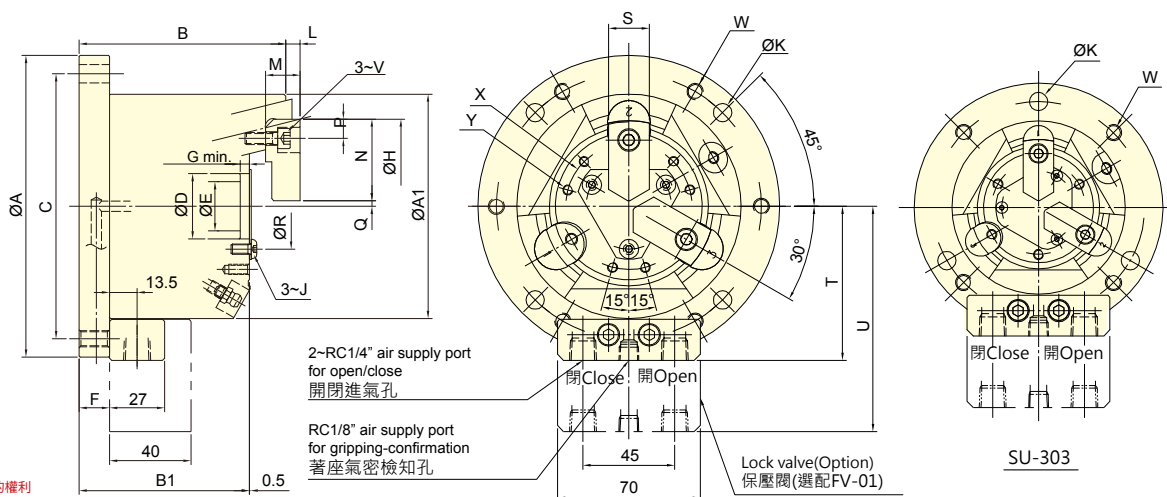

保留規格修改的權利
Subject to technical changes

SU-304,306,308,310

技術規格 SPECIFICATIONS

型號	爪行程 (直徑)	夾持直徑		最大夾持力		最大使用壓力		最低使用壓力	空氣消耗量 使用壓力6.0 kgf/cm ²	重量
		最大	最小	氣壓	油壓	氣壓	油壓			
		Max.	Min.	Pneumatic	Hydraulic	Pneumatic	Hydraulic			
Model	Jaw stroke (Dia.) mm	Chucking Dia. mm	mm	Max. clamping force kN(kgf)	kN(kgf)	Max. pressure MPa(kgf/cm ²)	MPa(kgf/cm ²)	Min. pressure kgf/cm ²	Air consumption lit (at 6.0 kgf/cm ²)	Weight kg
SU-303	2	42	4	5.2(530)	12.8(1305)	0.6(6)	1.3(13)	2	0.16	5.7
SU-304	3	60	5	6.7(683)	16.0(1632)	0.6(6)	1.3(13)	2	0.26	7.4
SU-306	5	105	31	18.5(1886)	40.0(4079)	0.6(6)	1.3(13)	2	0.58	18
SU-308	5	132	32	37.0(3773)	80.0(8158)	0.6(6)	1.3(13)	2	1.02	31.5
SU-310	5	163	44	46.2(4710)	100.0(10100)	0.6(6)	1.3(13)	2	2.11	53

外型尺寸 DIMENSIONS

Model	A(h7)	A1	B	B1	C	D(H6)	E	F	G	H(H6)	J	K	L max.	L min.
SU-303	122	85	80.5	68	104	28	22	12	3.5	66	M3	3~9	5	1
SU-304	148	110	101.5	83.5	130	32	24	15	4.5	84	M5	4~9	7	1
SU-306	206	168	136.5	104	188	35	25	18	6	129	M5	4~11	15	5
SU-308	248	210	152	115	230	55	45	18	7	156	M6	4~11	17	7
SU-310	300	254	181	131	280	65	53	20	7	187	M8	4~13	9	-1

Model	M	N	P	Q max.	Q min.	R	S	T	U	V	W	X (p.c.d)	Y
SU-303	12	30	7	3.5	2.5	36	15	63	98	M5	4~M8x1.25	46	3~M5x10
SU-304	17	40	9.5	2.75	1.25	42	20	75.5	110.5	M6	6~M8x1.25	62	6~M5x10
SU-306	30	50	17	15.75	13.25	49	30	104.5	139.5	M10	6~M10x1.5	72	6~M6x12
SU-308	34	63	20.5	16.25	13.75	71	35	125.5	160.5	M12	6~M10x1.5	95	6~M6x12
SU-310	39	74	23	20.75	18.25	85	40	147.5	182.5	M14	6~M12x1.75	115	6~M6x12



- 內建油壓缸，當使用氣壓做為動力源時，可選配保壓閥組件。
- 適用於內徑夾持。
- 高精度安定性，適合最後製程加工。
- 可與立置夾頭座板組合進行加工。
- Build-in hydraulic cylinder; it can also work with lock valve and be driven by air pressure.
- For internal gripping.
- With high precision and stability.
- Suitable for the precision large length size process.
- Suitable for end process.
- Can work together with multi-plate.
- 氣密檢知 (選配)。
- Airtight pressure detect function is optional.

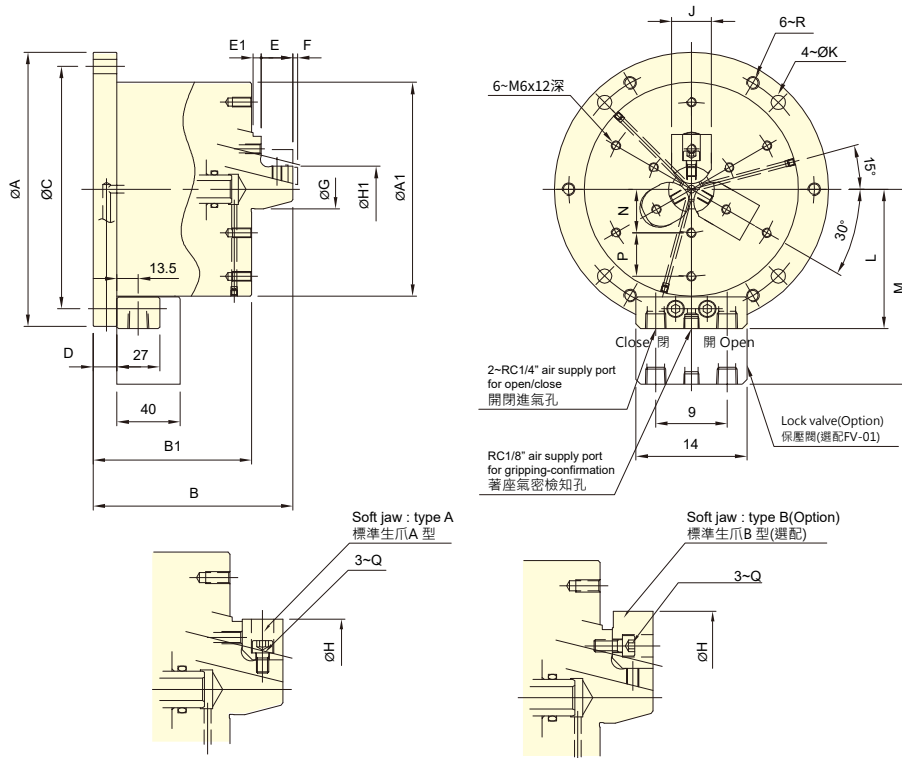

保留規格修改的權利
Subject to technical changes

技術規格 SPECIFICATIONS

型號	爪行程 (直徑)	夾持直徑		最大夾持力		最大使用壓力		最低使用壓力	空氣消耗量 使用壓力6.0 kgf/cm ²	重量
		最大	最小	氣壓	油壓	氣壓	油壓			
Model	Jaw stroke (Dia.)	Chucking Dia.		Max. clamping force		Max. pressure		Min. pressure	Air consumption	Weight
		Max.	Min.	Pneumatic	Hydraulic	Pneumatic	Hydraulic			
	mm	mm	mm	kN(kgf)	kN(kgf)	MPa(kgf/cm ²)	MPa(kgf/cm ²)	kgf/cm ²	lit (at 6.0 kgf/cm ²)	kg
SE-305	3	83	29	14.3 (1459)	41.0 (4181)	0.7 (7)	1.3 (13)	2	0.46	14.6
SE-306	5	110	44	20.0 (2040)	57.0 (5812)	0.7 (7)	1.3 (13)	2	0.58	20
SE-308	5	150	50	32.0 (3263)	78.0 (7954)	0.7 (7)	1.3 (13)	2	1.02	33

外型尺寸 DIMENSIONS

Model	A(h7)	A1	B	B1	C	D	E	E1	F max.	F min.	G	type A		type B	
												H max.	H min.	H max.	H min.
SE-305	173	135	126	100	155	15	20	5	3	-3	25	68	50	83	67
SE-306	206	168	140	108	188	18	23	7	5	-5	40	90	70	110	89
SE-308	248	210	164	119	230	18	30	9	5	-5	49	110	90	150	108

Model	H1		J	K	L	M	N	P	Q	R
	max.	min.								
SE-305	50	29	25	9	88	123	27.5	27.5	3~M6	M8x1.25
SE-306	70	44	31	11	104.5	139.5	38	29	3~M6	M10x1.5
SE-308	90	50	35	11	125.5	160.5	50	35	3~M8	M10x1.5



- 可用於銑床或加工中心機上，同時加工多個工件。
- 可選擇安裝立式氣缸用保壓閥。
- 可訂製2、3、6工件數的盤面。
- Use for milling machine or machining center to achieve simultaneous processing of multiple workpieces.
- Stationary cylinder lock valve (optional) can be mounted.
- Plate for 2,3,6 stationary chucks is optional.

立置式夾頭

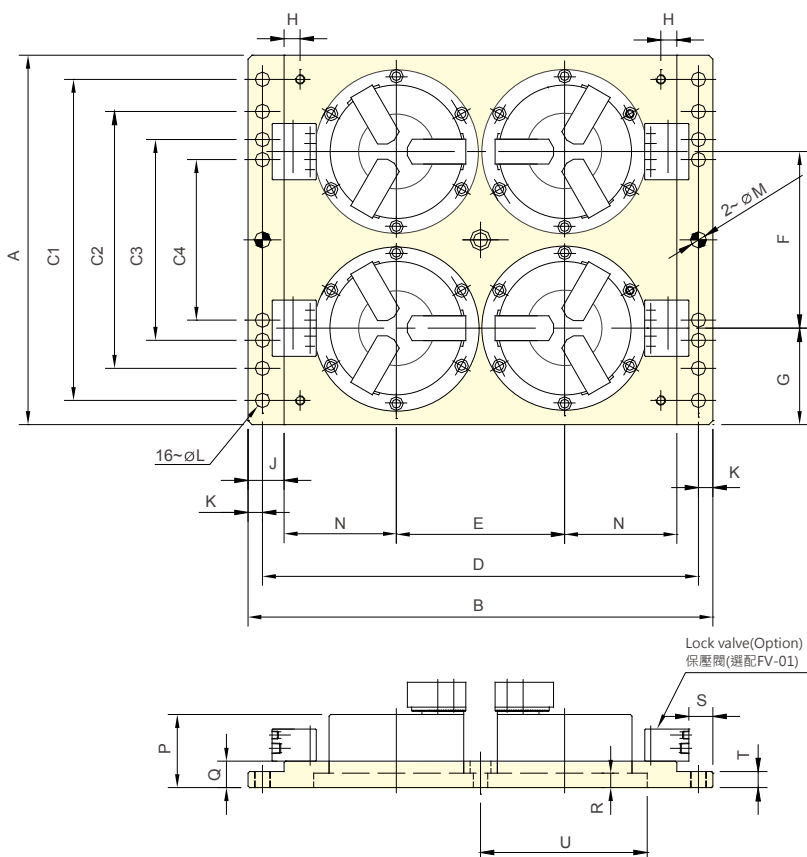

保留規格修改的權利
Subject to technical changes

外型尺寸 DIMENSIONS

Model	A	B	C1	C2	C3	C4	D	E	F	G
MP4-06206	460	580	400	320	250	200	544	210	220	120

Model	H	J	K	L	M	N	P	Q	R	S	T	U
MP4-06206	20	45	18	17	20	140	*B	33	18	20	20	206

*B 對照所裝配夾頭型號之寸法 B。
The dimension *B: Please refer to the dimension B of the chuck model assembled.



保留規格修改的權利
Subject to technical changes

最大容許壓力 Max. pressure MPa(kgf/cm ²)	操作角度 Operating angle	持續口徑 Port size
1.0 (10)	90 °	Rc1/4