

Subject to technical changes

DIMENSIONS

MODEL	S-1	S-2	S-3	S-4	S-5	S-6	S-7	S-8	S-9	S-10	S-11	S-12	S-13	Serration Pitch	Matching Chuck	3 Jaw Weight
																kg
SJ-04	52	23	23	10	5	10	14	28	9	14	13	M8	3	1.5×60°	3H-204, 3P-04	0.5
SJ-05	62	25	30	10	5	10	14	38	9	14	20	M8	3.5	1.5×60°	3H-205, 3L-205, 3P-05, 3M-05	0.8
SJ-06	73	31	36	12	5	15	20	38	11	17	24	M10	14	1.5×60°	3H-206, 3L-206, 3P-06, 3M-06	1.5
SJ-08	95	35	37	14	5	24	25	46	13	19	22	M12	16	1.5×60°	3H-208, 3L-208, 3P-08, 3M-08	2.4
SJ-10	110	40	42	16	5	30	30	50	13	19	27	M12	18	1.5×60°	3H-210, 3L-210, 3P-10, 3M-10	3.7
*SJ-12H	130	50	50	21	5	40	30	60	17	25	30	M16	23	1.5×60°	3H-12, 3H-212, 3L-212, 3V-12, 3P-12, 3M-12	6.3
SJ-12P	130	50	50	18	5	40	30	60	16	23	30	M14	23	1.5×60°	3H-12, 3H-212, 3L-212, 3V-12, 3P-12, 3M-12	6.5
SJ-15H	165	62	62	22	8	37	43	85	21	32	37	M20	-	1.5×60°	3H-15, 3H-215, 3H-18, 3L-15, 3P-215, 3P-218, 3V-15, 3V-18	12.6
*SJ-15P	165	62	62	25.5	6	37	43	85	21	32	37	M20	-	1.5×60°	3H-15, 3H-215, 3H-18, 3L-15, 3P-215, 3P-218, 3V-15, 3V-18	12.5
SJ-21	180	64	70	25	9	40	60	80	21	32	45	M20	-	3.0×60°	3H-221, 3H-224, 3H-232, 3P-221, 3P-224, 3V-21, 3V-24, 3V-32, 3M-221, 3M-224, SP-320, SP-324	15.8

* 12" Chucks are originally equipped with SJ-12H.

* 15" Chucks are originally equipped with SJ-15P.

STANDARD SOFT JAW FOR 3U CHUCK

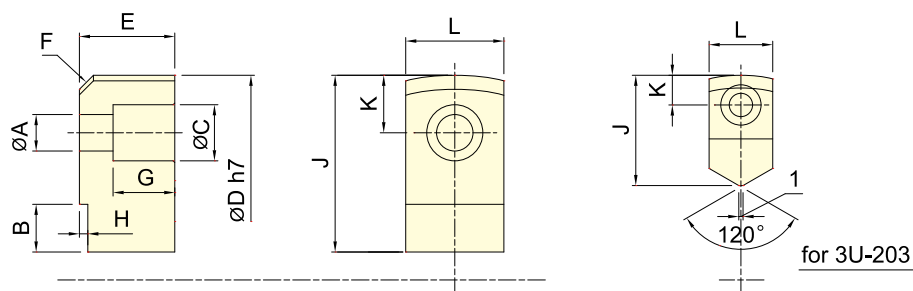

Subject to technical changes

DIMENSIONS

MODEL	A	B	C	D	E	F	G	H	J	K	L
3U-203	5.5	11	9.5	66	12	C3	7	3	26	7	15
3U-204	6.6	11	11	84	17	C4	11	3	32	9.5	20
3U-205	9	13.5	14	108	20	C4	12	3	41.5	13	24
3U-206	11	15	17	129	30	C6	20	3	50	17	30
3U-208	13	17	20	156	34	C6	22	3	63	20.5	35
3U-210	15	20	22	187	39	C6	24	4	74	23	40
3U-212	15	18	22	234	44	C6	29	4	72	23	40

STANDARD SOFT JAW FOR 2D/3D CHUCK

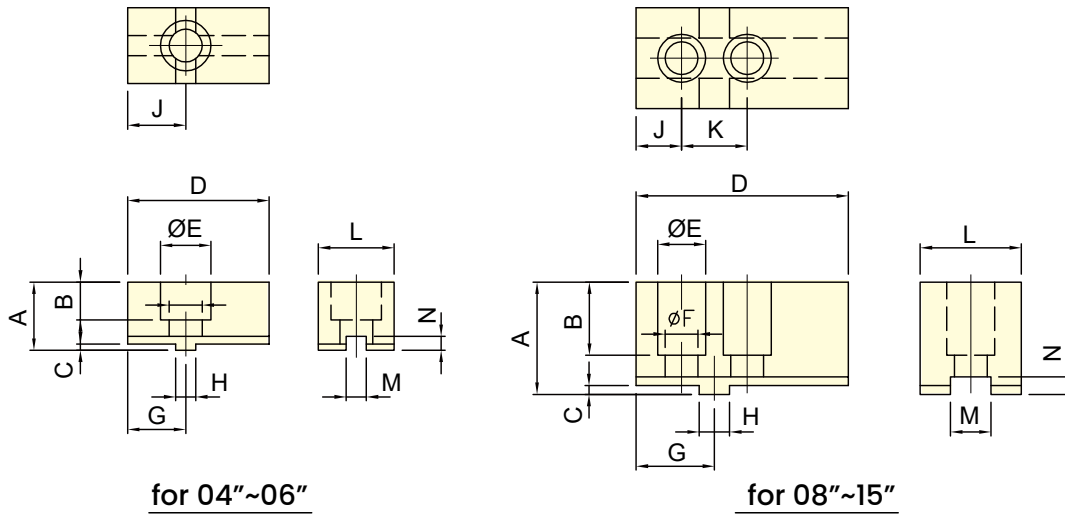

Subject to technical changes

DIMENSIONS

MODEL	A	B	C	D	E	F	G	H	J	K	L	M	N
3D-04	22	13	2.5	52	17.5	11	19	8	19	-	25	8	5.5
3D-05	27	15	2.5	56	20	13	23	8	23	-	30	8	5.5
3D-06	34	21	3	70	23	15.5	27	10	27	-	35	10	6
3D-08	44.5	29	3.5	84	19	13	31	12	18	26	40	16	7
3D-10	49.5	32	3.5	100	22	15	38	15	22	32	50	18	7
3D-12	54.5	36	3.5	120	26	18	42	17	24	36	60	20	7
3D-15	65	40	5	165	26	18	60	20	40	40	70	24	10

STANDARD SOFT JAW FOR 3E CHUCK

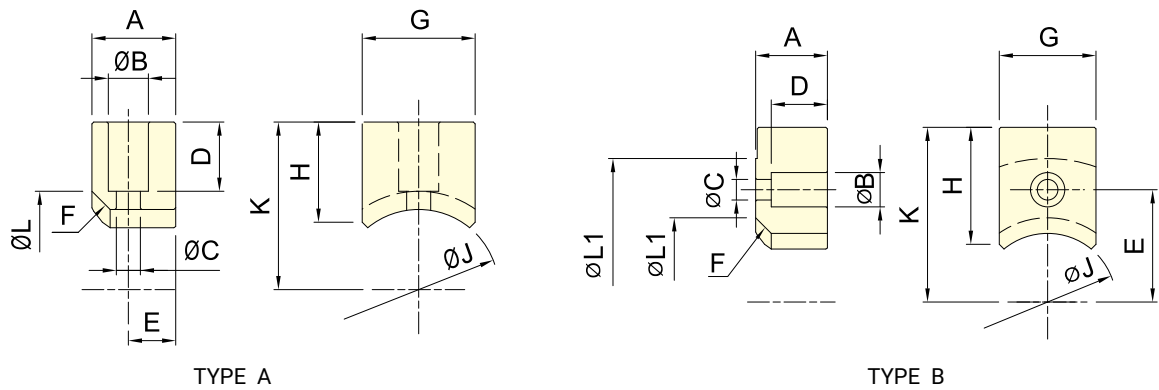

Subject to technical changes

DIMENSIONS

MODEL	A	B	C	D	E	F	G	H	J	K	L	L1	
3E-05	A Type	20	11	6.6	16.5	10	C5	25	22	29	34.5	39	-
	B Type	20	11	6.6	15	25.5	C5	25	30	29	42.5	39	69
3E-06	A Type	23	11	7	19	13	C5	31	27.5	44	46	54	-
	B Type	23	11	6.6	18	36	C5	31	37.5	44	56	54	92
3E-08	A Type	30	14	9	25	15	C6	35	36	50	56	62	-
	B Type	30	14	9	24	41	C6	35	56	50	76	62	112
3E-10	A Type	35	17.5	11	26.5	17.5	C5	40	40	60	64.5	70	-
	B Type	35	17.5	11	26	47.5	C5	40	71.5	60	96	70	129

STANDARD SOFT JAW FOR 3R CHUCK

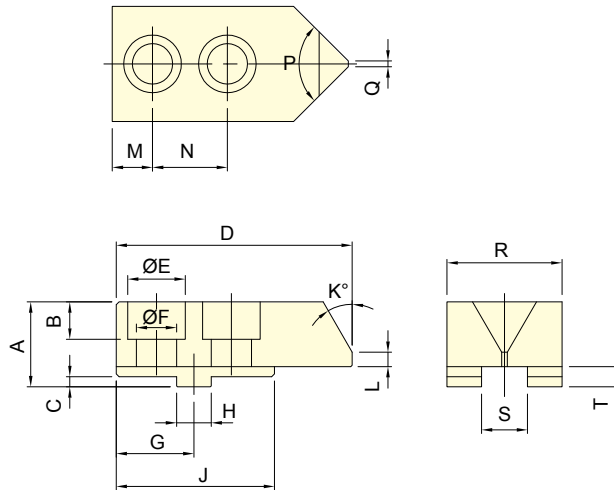

Subject to technical changes

DIMENSIONS

MODEL	A	B	C	D	E	F	G	H	J	K	L	M	N	P	Q	R	S	T
3R-08	29.5	13	3.5	82	20	14	27	12	55	30	5	14	26	90	2	40	16	7
3R-10	30.5	15	3.5	102	23	16	37	15	65	30	7	21	32	90	2	40	18	7

STANDARD SOFT JAW FOR 3W CHUCK

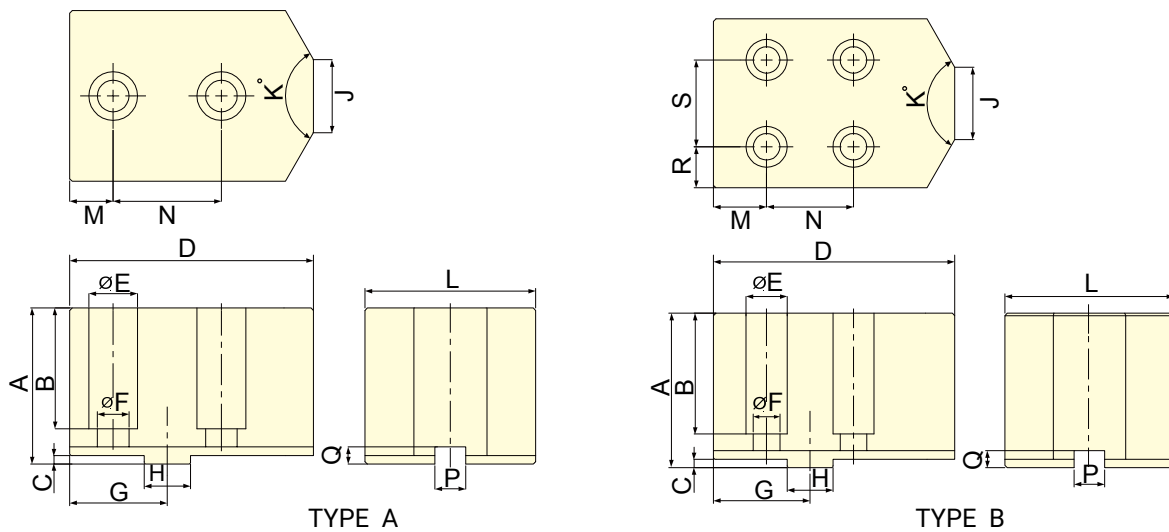

Subject to technical changes

DIMENSIONS

MODEL		A	B	C	D	E	F	G	H	J	K	L	M	N	P	Q	R	S
3W-08	A Type	60	44	3.5	80	20	13	35	12.68	30	120	57	16	38	7.94	7	-	-
	B Type	60	48	3.5	80	17	11	35	12.68	30	120	57	19	32	7.94	7	12.5	32
3W-10	A Type	64	49.5	3.5	100	20	13	40	19.03	30	120	70	17.8	44.4	12.7	7	-	-
	B Type	64	50	3.5	100	17	11	40	19.03	30	120	70	22	36	12.7	7	17	36
3W-12	A Type	64	49.5	3.5	100	20	13	40	19.03	30	120	70	17.8	44.4	12.7	7	-	-
	B Type	64	50	3.5	100	17	11	40	19.03	30	120	70	22	36	12.7	7	17	36

*3W series Carbide gripper is optional. * The type of the gripper is selected according to the work-piece conditions.

STANDARD SOFT JAW FOR 3MF CHUCK

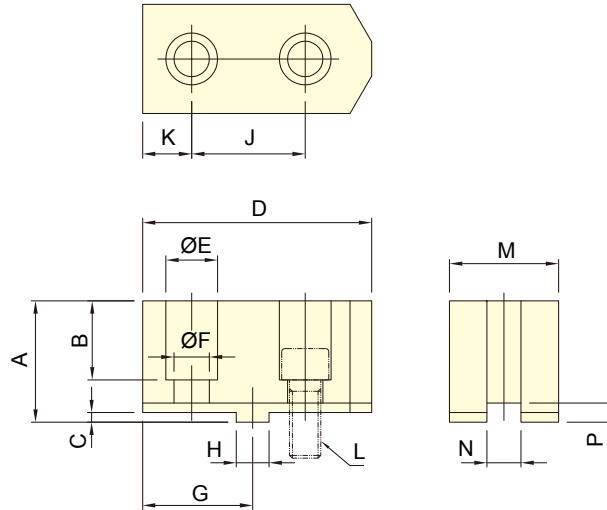

Subject to technical changes

DIMENSIONS

MODEL	A	B	C	D	E	F	G	H	J	K	L	M	N	P	3 Jaw Weight (kg)
3MF-20	70	48	6	160	25	17	80	19.03	76.2	41.9	M16	50	12.7	11.5	10.4

STANDARD SOFT JAW FOR AP CHUCK

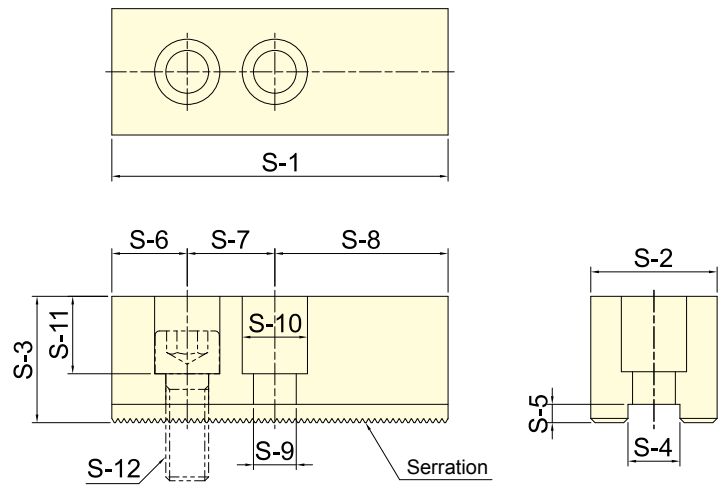

Subject to technical changes

DIMENSIONS

MODEL	S-1	S-2	S-3	S-4	S-5	S-6	S-7	S-8	S-9	S-10	S-11	S-12	Serration Pitch	Matching Chuck	3 Jaw Weight (kg)
SJ-185	165	62	62	25.5	9	37	43	85	21	32	38	M20	3.0 × 60°	AP-145, AP-185	12.2
SJ-275	180	64	70	25.5	9	40	60	80	21	32	45	M20	3.0 × 60°	AP-230, AP-275	16.1
SJ-320	210	75	80	30	9	40	60	110	26	38	55	M24	3.0 × 60°	AP-320, AP-375	24.7