

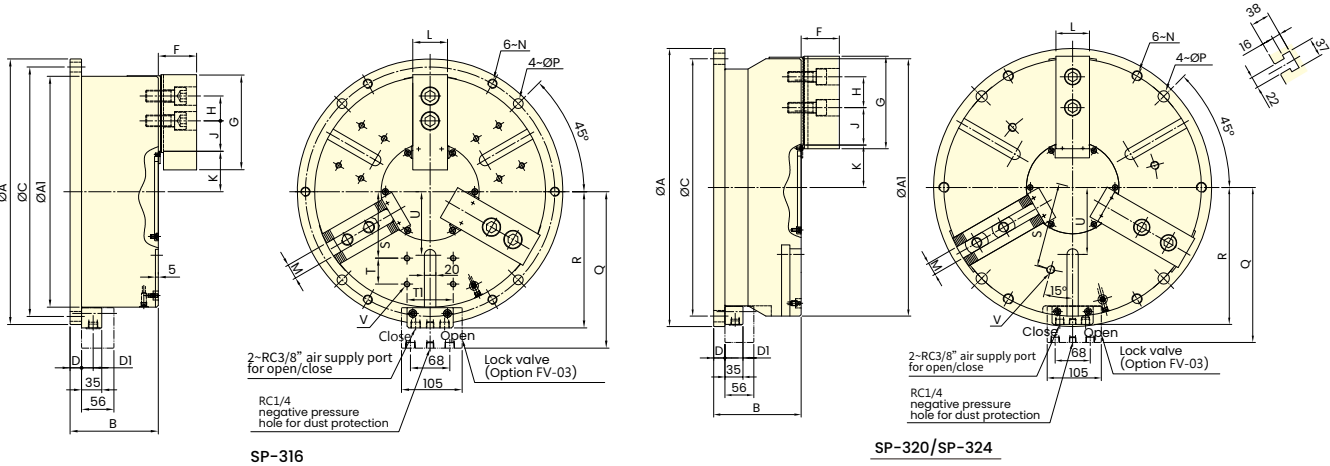

- Stationary Chucks – Non-Thru-Hole and Thru-Hole Types.
- Available in two jaw configurations: 2-jaw and 3-jaw.
- Equipped with a built-in hydraulic cylinder; compatible with lock valves and can also be operated using air pressure.
- Features a small thru-hole, making it ideal for machining long bar workpieces.
- Side and bottom air/hydraulic inlets available; either can be used for operation.
- Slim and compact design. Compatible with standard soft jaws or hard jaws.
- Suitable for rotary machining and can be installed on mill-turn machines.
- Can be integrated with multi-plate setups for enhanced versatility.

STATIONARY CHUCKS

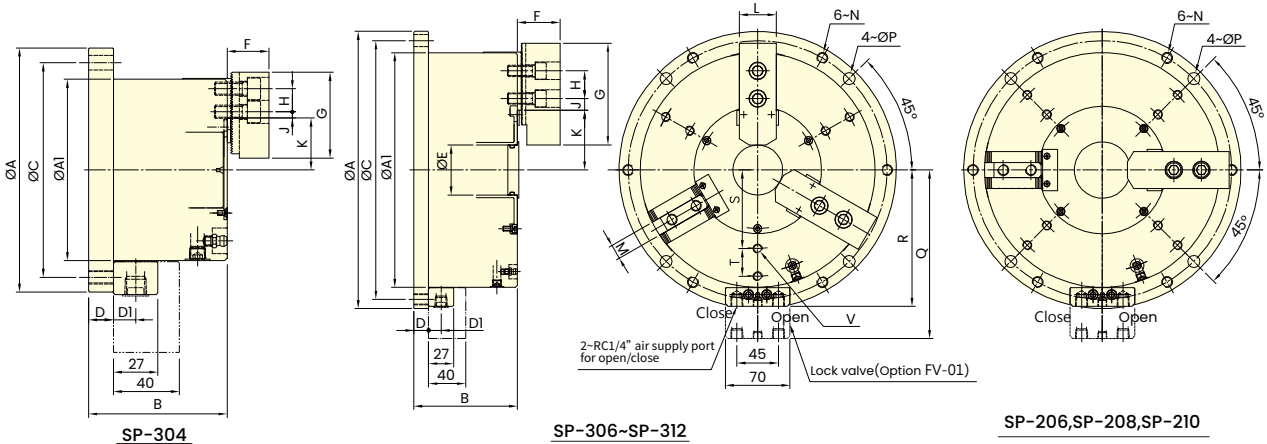

Subject to technical changes

## SPECIFICATIONS

Model	Jaw stroke (Dia.) mm	Chucking Dia.		Max. clamping force		Max. pressure		Min. pressure kgf/cm <sup>2</sup>	Air consumption lit (at 6.0 kgf/cm <sup>2</sup> )	Weight kg
		Max. mm	Min. mm	Pneumatic kN(kgf)	Hydraulic kN(kgf)	Pneumatic MPa(kgf/cm <sup>2</sup> )	Hydraulic MPa(kgf/cm <sup>2</sup> )			
SP-304	5.1	110	10	7.5(765)	22.0(2243)	0.7(7)	1.2(12)	2	0.5	7
SP-206	5.5	168	30	34.1(3477)	46.1(4752)	0.7(7)	1.2(12)	2	1.4	16
SP-306	5.5	168	30	35.5(3620)	60.0(5252)	0.7(7)	1.2(12)	2	1.4	16.5
SP-208	6.8	210	42	43.2(4405)	74.0(7545)	0.7(7)	1.2(12)	2	2.5	27.7
SP-308	6.8	210	42	51.5(5251)	88.3(9004)	0.7(7)	1.2(12)	2	2.5	28.7
SP-210	7	254	52	60.5(6169)	94.5(9636)	0.7(7)	1.2(12)	2	4.2	41.8
SP-310	7	254	52	68.2(6955)	118.7(12104)	0.7(7)	1.2(12)	2	4.2	42

Model	Jaw stroke (Dia.)	Chucking Dia.		Max. clamping force		Max. pressure		Min. pressure	Air consumption	Weight
		Max.	Min.	Pneumatic	Hydraulic	Pneumatic	Hydraulic			
	mm	mm	mm	kN(kgf)	kN(kgf)	MPa(kgf/cm <sup>2</sup> )	MPa(kgf/cm <sup>2</sup> )	kgf/cm <sup>2</sup>	lit (at 6.0 kgf/cm <sup>2</sup> )	kg
<b>SP-312</b>	9.3	304	60	75.8(7729)	148 (15091)	0.7(7)	1.2(12)	2	6.4	71.3
<b>SP-316</b>	14.5	400	30	120.7(12305)	120.7(12305)	0.7(7)	0.7(7)	2	10.6	147.8
<b>SP-320</b>	16	500	45	155.6(15865)	155.6(15865)	0.7(7)	0.7(7)	2	15	232.7
<b>SP-324</b>	16	600	140	215.9(22015)	215.9(22015)	0.7(7)	0.7(7)	2	22	338.7

## DIMENSIONS

Model	A(h7)	A1	B	C	D	D1	E	F	G	H	J max.	J min.
<b>SP-304</b>	148	110	84	130	15	13.5	-	25	52	14	3.75	0.75
<b>SP-206</b>	206	168	94	188	15	13.5	25	40	73	20	10.75	4.75
<b>SP-306</b>	206	168	94	188	15	13.5	25	40	73	20	10.75	4.75
<b>SP-208</b>	248	210	108	230	15	13.5	32	41	95	25	16.25	8.75
<b>SP-308</b>	248	210	108	230	15	13.5	32	41	95	25	16.25	8.75
<b>SP-210</b>	300	254	112	280	16	13.5	54	46	110	30	23.25	12.75
<b>SP-310</b>	300	254	112	280	16	13.5	54	46	110	30	23.25	12.75
<b>SP-312</b>	350	304	130	330	18	13.5	65	54	130	30	30.75	12.75
<b>SP-316</b>	460	400	153	432	20	20	-	66	165	43	67.75	18.25
<b>SP-320</b>	540	500	170	500	22	20	-	74	180	60	87.5	24.5
<b>SP-324</b>	640	600	175	600	24	20	-	74	180	60	87.5	24.5

Model	K max.	K min.	L	M	N	P	Q	R	S	T	T1	U	V
<b>SP-304</b>	31.5	28.95	23	10	M8x1.25	9	110.5	75.5	-	-	-	-	-
<b>SP-206</b>	47	44.25	31	12	M10x1.5	11	139.5	104.5	55	18	-	-	6~M8x1.25
<b>SP-306</b>	47	44.25	31	12	M10x1.5	11	139.5	104.5	55	18	-	-	6~M8x1.25
<b>SP-208</b>	53	49.6	35	14	M10x1.5	11	160.5	125.5	68	25	-	-	6~M8x1.25
<b>SP-308</b>	53	49.6	35	14	M10x1.5	11	160.5	125.5	68	25	-	-	6~M8x1.25
<b>SP-210</b>	64.5	61	40	16	M12x1.75	13	182.5	147.5	85	30	-	-	6~M10x1.5
<b>SP-310</b>	64.5	61	40	16	M12x1.75	13	182.5	147.5	85	30	-	-	6~M10x1.5
<b>SP-312</b>	77.5	72.85	50	21	M12x1.75	13	207.5	172.5	100	35	-	-	6~M10x1.5
<b>SP-316</b>	70	62.75	60	25.5	M16x2.0	17.5	271	236	115	45	80	110	12~M10x1.5
<b>SP-320</b>	82.5	74.5	64	25	M20x2.5	22	301	266	165	-	-	130	3~M16x2.0
<b>SP-324</b>	129.5	121.5	64	25	M20x2.5	22	351	316	200	-	-	180	3~M16x2.0