

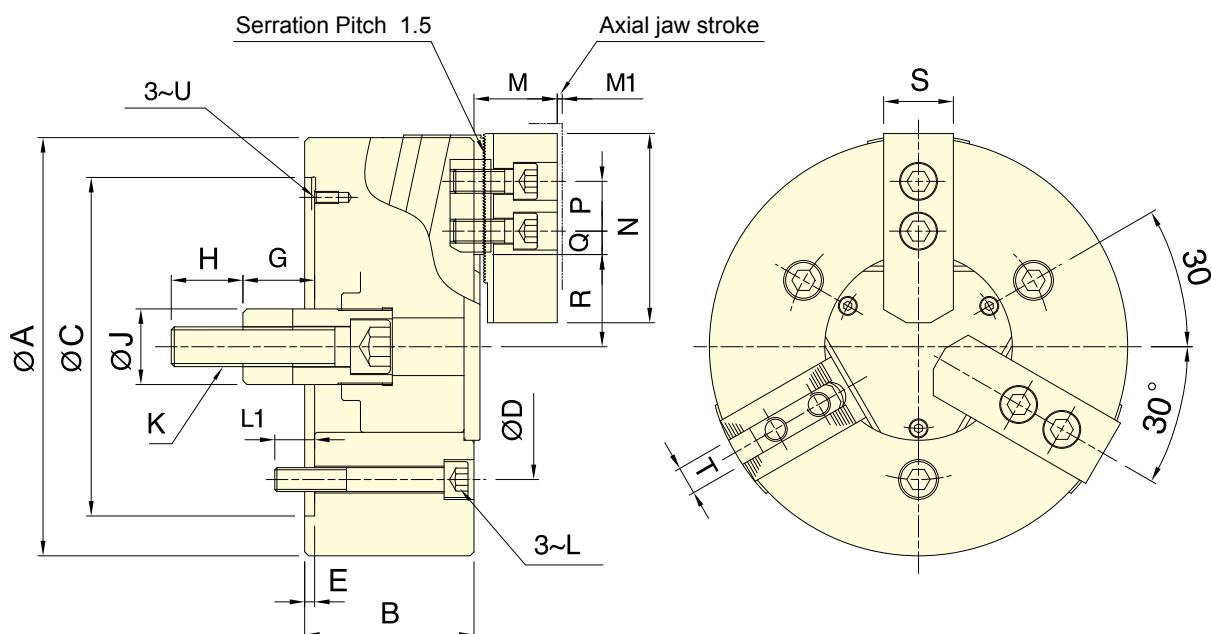

- The surface of the center through cover is grinding treated, it can be the position base surface of the jig/workpiece.
- The sideway of main jaws is inclined. It improves the clamping force and reduces the upfloat situation of the workpiece.
- Work with standard top jaws.
- Airtight pressure detect function is optional.
- External gripping only.



Subject to technical changes

SPECIFICATIONS

Model	Plunger stroke	Jaw stroke (Dia.)	Chucking Dia.Max.	Chucking Dia.Min.	Max. D.B. pull	Max. Clamping force	Max. speed	Moment of inertia	Weight	Matching cyl.	Max. pressure
	mm	mm	mm	mm	kN (kgf)	kN (kgf)	min ⁻¹ (r.p.m.)	kg·m ²	kg		MPa (kgf/cm ²)
3N-06	20	8.1 (axial 0.9)	165	14	18 (1835)	61.5 (6270)	5000	0.05	11.1	RK-100(N)	2.6 (26)
3N-08	23	9.4 (axial 1.0)	210	17	25 (2540)	85.8 (8750)	4500	0.14	24.5	RK-125(N)	2.2 (22)
3N-10	25	10.2 (axial 1.1)	254	22	29 (2950)	108 (11000)	4000	0.32	34.5	RK-150(N)	1.8 (18)

DIMENSIONS

Model	A	B	C(H6)	D	E	G max.	G min.	H	J	K	L
3N-06	165	72	140	104.8	5	54.5	34.5	36	34	M16x2	M10
3N-08	210	85	170	133.4	5	59	36	36	38	M20x2.5	M12
3N-10	254	89	220	171.4	5	63	38	36	45	M20x2.5	M16

Model	L1	M	M1	N	P	Q max.	Q min.	R max.	R min.	S	T	U
3N-06	16	41	0.9	73	20	15.25	7.75	38.3	34.25	31	12	M6
3N-08	20	42	1.0	95	25	22.25	11.75	46.3	41.6	35	14	M6
3N-10	24	47	1.1	110	30	33.75	11.25	52.1	47	40	16	M8



- Radial clamp and axial pull down at the same time, keep the workpiece attaching close to the base surface of the chuck.
- Almost no workpiece uplifting displacement.
- The body and the cylinder pull-down mechanism are heat-treated and fine boring, which guarantee the clamping precision and durability.
- Airtight pressure detect function is optional.

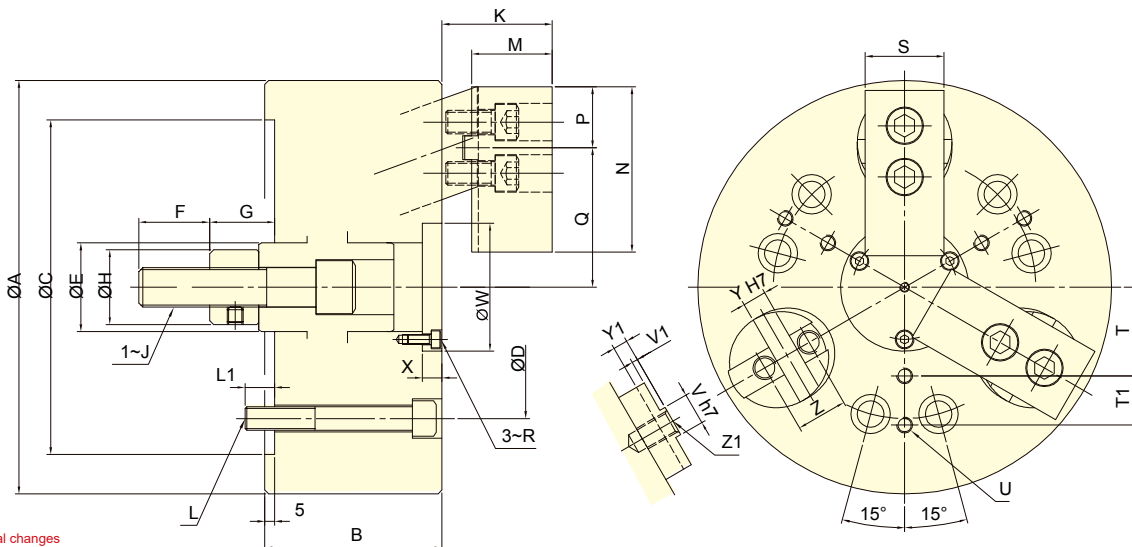

Subject to technical changes

SPECIFICATIONS

Model	Plunger stroke	Jaw stroke (Dia.)	Chucking Dia. Max.	Chucking Dia. Min.	Max. D.B. pull	Max. Clamping force	Max. speed	Moment of inertia	Weight	Matching cyl.	Max. pressure
	mm	mm	mm	mm	kN (kgf)	kN (kgf)	min ⁻¹ (r.p.m.)	kg-m ²	kg		MPa (kgf/cm ²)
3D-04	7	5	110	13	6.0(612)	10.5(1070)	3500	0.007	4.5	RK-75	1.6(16.5)
3D-05	7	5	135	21	10.0(1020)	17.0(1730)	3500	0.018	7.9	RK-75	2.7(27.5)
3D-06	10	7.2	165	22	15.0(1530)	25.0(2550)	3500	0.051	15	RK-100	2.1(21.4)
3D-08	10	7.2	210	28	25.0(2550)	45.0(4590)	3000	0.15	26	RK-125	2.2(22.5)
3D-10	15	10.8	254	35	35.0(3569)	60.0(6118)	2500	0.37	46	RK-125	3.1(31.6)
3D-12	15	10.8	304	50	45.0(4590)	75.0(7650)	2000	0.79	70	RK-150	2.8(28.5)
3D-15	20	14.5	381	60	53.9(5500)	90.0(9180)	1500	2.25	132	RK-150	3.4(34.2)

DIMENSIONS

Model	A	B	C (H6)	D	E	F	G max.	G min.	H	J	K max.	K min.	L	L1	M	N	P
3D-04	110	60	85	70.6	25	20	22	15	25	M10	30	23	3~M10	15	19.5	50	22
3D-05	135	70	110	82.6	30	25	24	17	28	M12	35	28	3~M10	16	24.5	56	23
3D-06	165	85	140	104.8	35	36	37	27	32	M16	45	35	6~M10	16	31	70	27
3D-08	210	90	170	133.4	45	36	38	28	38	M20	56	46	6~M12	15	41	84	31
3D-10	254	110	220	171.4	55	46	47	32	50	M24	65	50	6~M16	24	46	100	38
3D-12	304	125	220	171.4	55	50	49.5	34.5	53	M27	70	55	6~M16	22	51	120	42
3D-15	381	140	300	235	70	55	61	41	55	M30	86	66	6~M20	30	60	165	60

Model	Q max.	Q min.	R	S	T	T 1	U	V (h7)	V 1	W	X	Y(H7)	Y1	Z	Z1
3D-04	37	34.5	M3	25	22.5	-	3~M6	8	2.5	35	4.5	8	6	-	M10
3D-05	46	43.5	M3	30	27.5	-	3~M6	8	2.5	44	4.5	8	6	-	M12
3D-06	57.7	54.3	M4	35	35	20	6~M6	10	2.5	52	7	10	6.5	-	M14
3D-08	70.8	67.2	M5	40	45	25	6~M8	16	3	65	10	12	7.5	26	M12
3D-10	85	79.6	M6	50	55	30	6~M8	18	3	75	12	15	7.5	32	M14
3D-12	101.9	96.5	M6	60	70	35	6~M10	20	3	90	12	17	7.5	36	M16
3D-15	135.6	128.3	M8	70	95	45	6~M12	24	4	120	13	20	6	40	M16



- Radial clamp and axial pull down at the same time, keep the workpiece attaching close to the base surface of the chuck.
- Almost no workpiece uplifting displacement.
- The body and the cylinder pull-down mechanism are heat-treated and fine boring, which guarantee the clamping precision and durability.
- Airtight pressure detect function is optional.

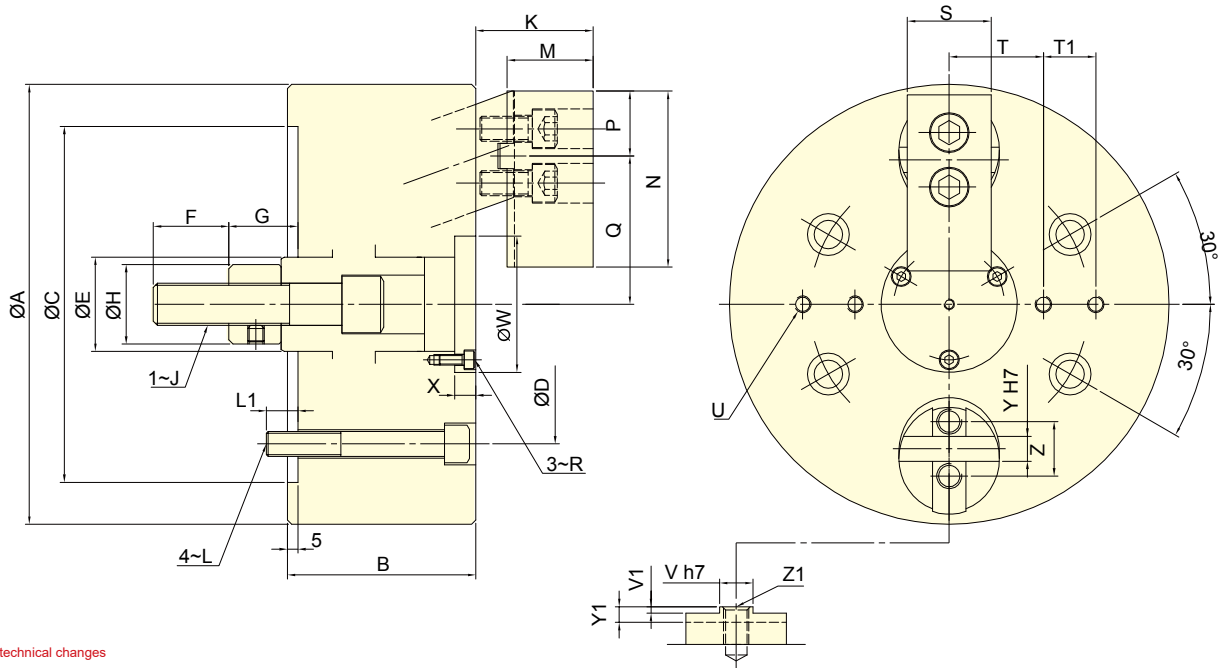

Subject to technical changes

SPECIFICATIONS

Model	Plunger stroke	Jaw stroke (Dia.)	Chucking Dia.Max.	Chucking Dia.Min.	Max. D.B. pull	Max. Clamping force	Max. speed	Moment of inertia	Weight	Matching cyl.	Max. pressure
	mm	mm	mm	mm	kN (kgf)	kN (kgf)	min ⁻¹ (r.p.m.)	kg·m ²	kg		MPa (kgf/cm ²)
2D-05	7	5	135	21	6.6(680)	11.0(1150)	3500	0.018	7.7	RK-75	1.8(18.3)
2D-06	10	7.2	165	22	10.0 (1020)	16.7 (1700)	3500	0.045	12	RK-100	1.4 (14.3)
2D-08	10	7.2	210	28	16.7 (1700)	30.0 (3060)	3000	0.13	23	RK-125	1.5 (15)
2D-10	15	10.8	254	35	23.3 (2379)	40.0 (4079)	2500	0.34	43	RK-125	2.1 (21.1)
2D-12	15	10.8	304	50	30.0(3060)	50.0(5100)	2000	0.73	71	RK-150	1.9(19.0)

DIMENSIONS

Model	A	B	C (H6)	D	E	F	G max.	G min.	H	J	K max.	K min.	L	L 1	M	N	P
2D-05	135	70	110	82.6	30	25	24	17	28	M12	35	28	M10	16	24.5	56	23
2D-06	165	85	140	104.8	35	36	37	27	32	M16	45	35	M10	16	31	70	27
2D-08	210	90	170	133.4	45	36	38	28	38	M20	56	46	M12	15	41	84	31
2D-10	254	110	220	171.4	55	46	47	32	50	M24	65	50	M16	24	46	100	38
2D-12	304	125	220	171.4	55	50	49.5	34.5	53	M27	70	55	M16	22	51	120	42

Model	Q max.	Q min.	R	S	T	T1	U	V (h7)	V 1	W	X	Y (H7)	Y1	Z	Z1
2D-05	46	43.5	M3	30	27.5	-	2~M6	8	2.5	44	4.5	8	6	-	M12
2D-06	57.7	54.3	M4	35	35	20	4~M6	10	2.5	52	7	10	6.5	-	M14
2D-08	70.8	67.2	M5	40	45	25	4~M8	16	3	65	10	12	7.5	26	M12
2D-10	85	79.6	M6	50	55	30	4~M8	18	3	75	12	15	7.5	32	M14
2D-12	101.9	96.5	M6	60	70	35	4~M10	20	3	90	12	17	7.5	36	M16



- Suitable for internal gripping.
- Radial clamp and axial pull down at the same time, keep the workpiece attaching close to the base surface of the chuck.
- Almost no workpiece uplifting displacement.
- With high precision and stability that chuck suitable for end process.
- Airtight pressure detect function is optional.

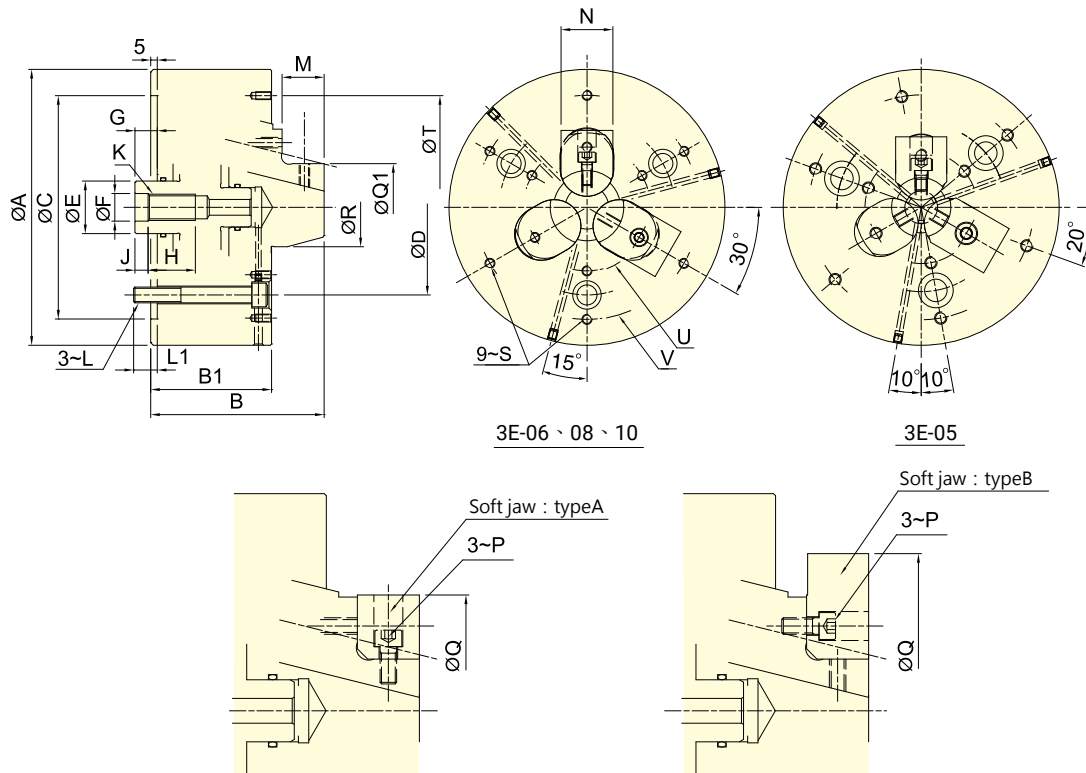

Subject to technical changes

SPECIFICATIONS

Model	Plunger stroke	Jaw stroke (Dia.)	Chucking Dia.Max.	Chucking Dia.Min.	Max. D.B. pull	Max. Clamping force	Max. speed	Moment of inertia	Weight	Matching cyl.	Max. pressure
	mm	mm	mm	mm	kN (kgf)	kN (kgf)	min ⁻¹ (r.p.m.)	kg-m ²	kg		MPa (kgf/cm ²)
3E-05	6	3	83	29	13.0(1325)	42.0(4280)	7000	0.018	7.5	RK-100	1.8(18.5)
3E-06	10	5	110	44	18.0(1835)	58.0(5910)	6000	0.042	13.6	RK-100	2.5(25.6)
3E-08	10	5	150	50	25.0(2530)	80.0(8150)	5000	0.14	26.5	RK-125	2.2(22.5)
3E-10	10	5	190	60	35.0(3570)	100.0(10200)	3600	0.31	39.5	RK-150	2.8(28.5)

DIMENSIONS

Model	A	B	B1	C (H6)	D	E	F (H8)	G max.	G min.	H	J	K	L	L1
Model	M	N	P	Q max.	Q min.	Q max.	Q min.	max.	min.	R	S	T	U (p.c.d)	V (p.c.d)
3E-05	20	25	M6	68	50	83	67	50	29	25	M6x12	110	55	110
3E-06	23	31	M6	90	70	110	89	70	44	40	M6x12	130	76	134
3E-08	30	35	M8	110	90	150	108	90	50	49	M6x12	170	100	170
3E-10	35	40	M10	127	110	190	125	110	60	59	M8x16	210	120	210



- Pin-Arbor Draw Down type 3-jaw thru-hole power chuck.
- High radial gripping force and high accuracy.
- Suitable for heavy machining.

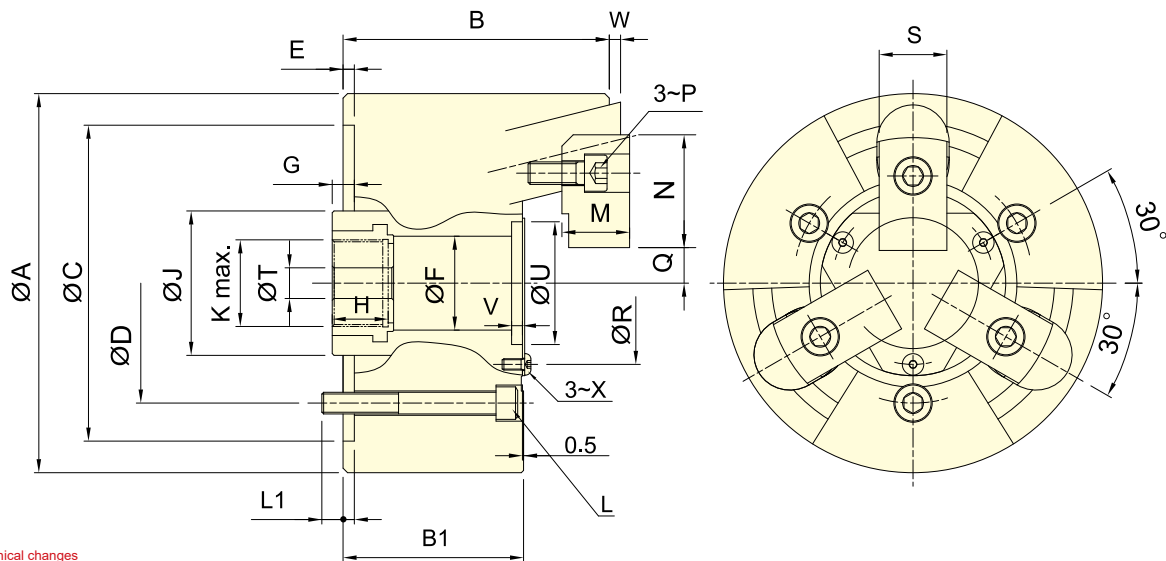

Subject to technical changes

SPECIFICATIONS

Model	Plunger stroke	Jaw stroke (Dia.)	Chucking Dia.Max.	Chucking Dia.Min.	Max. D.B. pull	Max. Clamping force	Max. speed	Moment of inertia	Weight	Matching cyl.	Max. pressure
	mm	mm	mm	mm	kN (kgf)	kN (kgf)	min ⁻¹ (r.p.m.)	kg·m ²	kg		MPa (kgf/cm ²)
3U-203	4	2	42	14	5.8(590)	16.7(1700)	10000	0.001	1.8	RK-75(N)	1.6(16)
3U-204	6	3	60	10	10.0(1020)	28.4(2900)	8000	0.005	3.9	RK-75(N)	2.7(27)
3U-205	6	3	84	15	13.9(1420)	39.7(4050)	8000	0.012	6.8	RK-100(N)	2.0(20)
3U-206	10	5	105	24	17.9(1830)	57.8(5900)	7000	0.055	14.7	RK-100(N)	2.6(26)
3U-208	12	6	132	25	25.0(2550)	80.0(8150)	6000	0.14	25.5	RK-125(N)	2.2(22)
3U-210	10	5	163	34	31.0(3160)	100.0(10100)	4500	0.36	43.5	RK-125(N)	3.1(31)
3U-212	10	5	210	81	35.0(3570)	100.0(10100)	3600	0.68	63.0	RK-125(N)	3.1(31)

DIMENSIONS

Model	A	B	B1	C(H6)	D	E	F	G max.	G min.	H	J	K	L	L1
3U-203	85	54.5	42	70	54	3.5	25	18	14	22	38	M20x1.5	3~M8	11
3U-204	110	72.5	55	85	70.6	4	30	16	10	24.5	42	M24x1.5	3~M10	12
3U-205	135	84.5	63	110	82.6	4	35	16	10	26	50	M28x1.5	3~M10	15
3U-206	168	118	80	140	104.8	5	45	20	10	31	60	M38x1.5	3~M10	16.5
3U-208	210	137	92	170	133.4	5	52	23	11	31	80	M48x2	3~M12	18
3U-210	254	152	102	220	171.4	5	75	25	15	37	105	M68x2	3~M16	23
3U-212	304	157	102	220	171.4	5	100	25	15	37	135	M92x2	3~M16	26

Model	M	N	P	Q max.	Q min.	R	S	T	U(H6)	V	W max.	W min.	X
3U-203	12	26	M5	7.5	6.5	38	15	10	32	3.5	2	-2	M3
3U-204	17	40	M6	10.75	9.25	46	20	10	38	4	3	-3	M4
3U-205	20	41.5	M8	13.25	11.75	55	24	10	45	5	3	-3	M5
3U-206	30	50	M10	15.75	13.25	72	30	17	58	6	5	-5	M5
3U-208	34	63	M12	16.25	13.25	82	35	17	68	6	5	-7	M6
3U-210	39	74	M14	20.75	18.25	107	40	17	93	6	5	-5	M8
3U-212	44	74	M14	44.25	41.75	130	40	17	114	6	5	-5	M10



- Pin-Arbor Draw Down type 3-jaw non-thru-hole power chuck.
- High radial gripping force and high accuracy.
- Suitable for heavy machining.
- Can work with the airtight detection device to perform axial position confirm, suitable for the precision of large length size process.

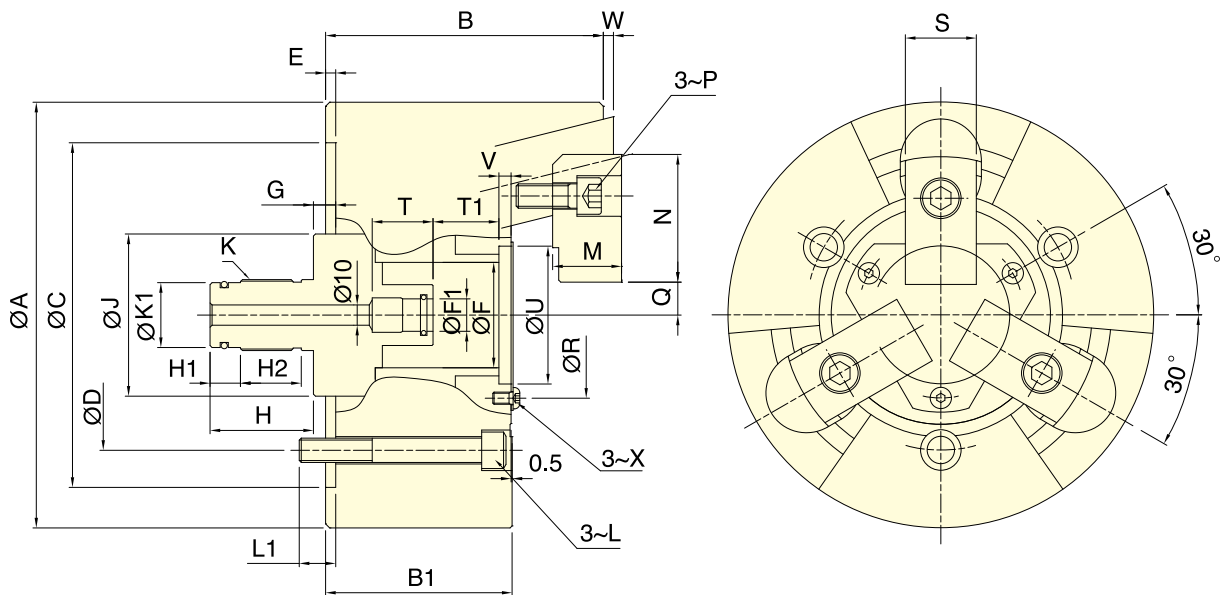

Subject to technical changes

SPECIFICATIONS

Model	Plunger stroke	Jaw stroke (Dia.)	Chucking Dia. Max.	Chucking Dia. Min.	Max. D.B. pull	Max. Clamping force	Max. speed	Moment of inertia	Weight	Matching cyl.	Max. pressure
	mm	mm	mm	mm	kN (kgf)	kN (kgf)	min ⁻¹ (r.p.m.)	kg·m ²	kg		MPa (kgf/cm ²)
3U-205K	6	3	84	15	13.9(1420)	39.7(4050)	8000	0.018	6.8	RL-100, RL-A100N	2.0(20)
3U-206K	10	5	105	24	17.9(1830)	57.8(5900)	7000	0.055	14.9	RL-100, RL-A100N	2.5(25)
3U-208K	12	6	132	25	25.0(2550)	80.0(8150)	6000	0.14	25.8	RL-125, RL-A125N	2.2(22)
3U-210K	10	5	163	34	31.0(3160)	100(10100)	4500	0.36	44.0	RL-125, RL-A125N	3.1(31)
3U-212K	10	5	210	81	35.0(3570)	100(10100)	3600	0.68	63.8	RL-125, RL-A125N	3.1(31)

DIMENSIONS

Model	A	B	B1	C(H6)	D	E	F	F1(H8)	G max.	G min.	H	H1	H2	J	K	K1	L
3U-205K	135	84.5	63	110	82.6	4	35	14	16	10	42	12	-	50	M25x1.5	22	M10
3U-206K	168	118	80	140	104.8	5	45	14	20	10	48	12	30	60	M28x1.5	24	M10
3U-208K	210	137	92	170	133.4	5	52	16	23	11	51	15	30	80	M35x1.5	30	M12
3U-210K	254	152	102	220	171.4	5	75	16	25	15	51	15	30	105	M38x1.5	34	M16
3U-212K	304	157	102	220	171.4	5	100	16	25	15	51	15	30	135	M45x1.5	40	M16

Model	L1	M	N	P	Q max.	Q min.	R	S	T	T1	U(H6)	V	W max.	W min.	X
3U-205K	15	20	41.5	M8	13.25	11.75	55	24	25	15.5	45	5	3	-3	M5
3U-206K	16.5	30	50	M10	15.75	13.25	72	30	30	26.5	58	6	5	-5	M5
3U-208K	18	34	63	M12	16.25	13.25	82	35	30	32.5	68	6	5	-7	M6
3U-210K	23	39	74	M14	20.75	18.25	107	40	30	36.5	93	6	5	-5	M8
3U-212K	26	44	74	M14	44.25	41.75	130	40	30	36.5	114	6	5	-5	M10



SPECIAL PURPOSE POWER CHUCKS

- Swing and grasp the workpiece to three jaw. (3W is automatically positioned to the center type.)
- Suitable for such materials as the casting and forging to process.
- Suitable for heavy machining.
- Seal proof for dust and cutting fluid, it is more convenient when maintenance.
- Swing parts are to heat treatment hardened and ground for steel, in order to improve products service life.
- Swing and grasp the workpiece to three jaw.(3W-C is center compensation type .)
- The workpieces compensation of eccentric is 2 mm, fixed position for the center thimble.
- Carbide gripper is optional. * The type of the carbide gripper is selected according to the work-piece conditions.
- According to different processing requirements, O.D. Gripping and I.D. Gripping can be interchanged.

Type of the Carbide gripper

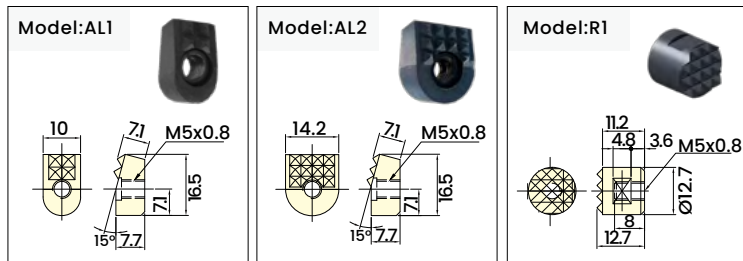

O.D. Gripping

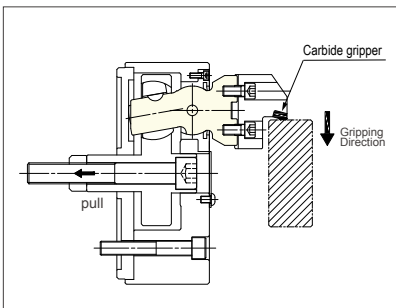

I.D. Gripping

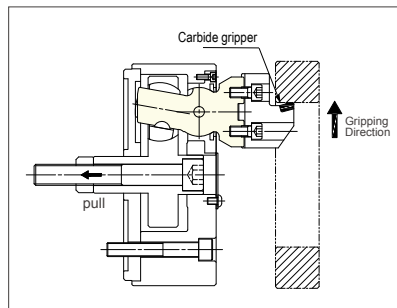

Min. Gripping range

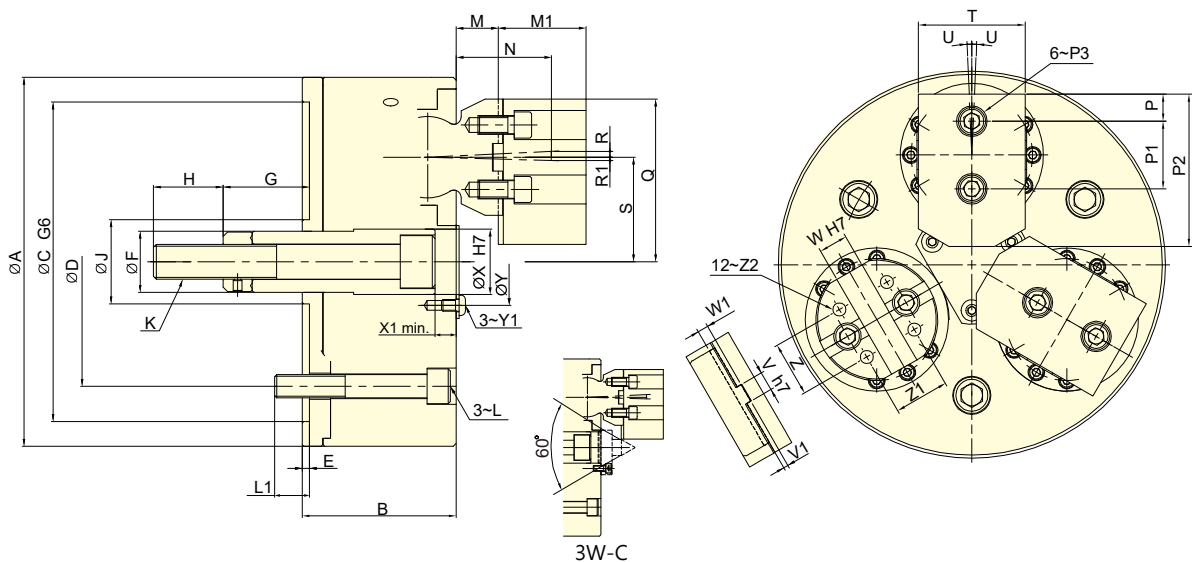
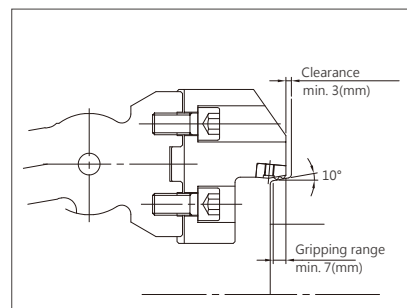

Subject to technical changes

SPECIFICATIONS

Model	Plunger stroke	Jaw stroke (Dia.)	Chucking O.D. Min.-Max.	Chucking I.D. Min.-Max.	Max. D.B. pull	Max. clamping force	Max. speed	Moment of inertia	Weight	Matching cyl.	Compensation
	mm	mm	mm	mm	kN (kgf)	kN (kgf)	min ⁻¹ (r.p.m.)	kg·m ²	kg		mm
3W-08	14.4	9.8	16~150	76~203	25(2550)	85.0(8670)	3700	0.12	23	RK-100(N)	-
3W-C08	14.4	9.8	16~150	76~203	25(2550)	85.0(8670)	3700	0.12	23	RK-100(N)	2
3W-10	17.5	12.5	50~205	85~235	35.3(3600)	105.9(10800)	2500	0.37	48.6	RK-125(N)	-
3W-C10	17.5	12.5	50~205	85~235	35.3(3600)	105.9(10800)	2500	0.37	48.6	RK-125(N)	2
3W-12	17.5	12.5	63~240	127~305	35.3(3600)	105.9(10800)	2400	0.73	65	RK-125(N)	-
3W-C12	17.5	12.5	63~240	127~305	35.3(3600)	105.9(10800)	2400	0.73	65	RK-125(N)	2
3W-15	22.5	15.9	76~317	165~381	56(5600)	168.2(16800)	2000	1.81	97	RK-150(N)	-
3W-C15	22.5	15.9	76~317	165~381	56(5600)	168.2(16800)	2000	1.81	97	RK-150(N)	3

DIMENSIONS

Model	A	B	C (G6)	D	E	F	G max.	G min.	H	J	K	L	L1	M	M1	N	P	P1	P2
3W-08	210	89	170	133.4	5	34	51.9	37.5	40	50	M18x2.5	M12	19	19.3	56.5	52.7	16	38	80
3W-C08	210	89	170	133.4	5	34	51.9	37.5	40	50	M18x2.5	M12	19	19.3	56.5	52.7	16	38	80
3W-10	254	106	220	171.4	5	42	67.5	50	48	58	M24x3	M16	24	29	60.5	65.6	17.8	44.4	100
3W-C10	254	106	220	171.4	5	42	67.5	50	48	58	M24x3	M16	24	29	60.5	65.6	17.8	44.4	100
3W-12	304	106	220	171.4	5	42	67.5	50	48	58	M24x3	M16	24	29	60.5	65.6	17.8	44.4	100
3W-C12	304	106	220	171.4	5	42	67.5	50	48	58	M24x3	M16	24	29	60.5	65.6	17.8	44.4	100
3W-15	381	120	300	235	5	55	62.5	40	46	80	M27x3	M20	30	32.4	72	74.3	19	63.5	140
3W-C15	381	120	300	235	5	55	62.5	40	46	80	M27x3	M20	30	32.4	72	74.3	19	63.5	140

Model	P3	Q	R	R1	S	T	U	V (h7)	V1	W (H7)	W1	X(H7)	X1	Y	Y1	Z	Z1	Z2
3W-08	M12	95	2.69	2.24	60	57	2	7.94	3	12.68	7	34	3.5	46	M6	32	32	M10
3W-C08	M12	95	2.69	2.24	60	57	2	7.94	3	12.68	7	34	3.5	46	M6	32	32	M10
3W-10	M12	112	4.03	2.26	72	70	2.5	12.7	3	19.03	7	45	5	60	M8	36	36	M10
3W-C10	M12	112	4.03	2.26	72	70	2.5	12.7	3	19.03	7	45	5	60	M8	36	36	M10
3W-12	M12	132.5	4.03	2.26	92.5	70	2.5	12.7	3	19.03	7	45	5	60	M8	36	36	M10
3W-C12	M12	132.5	4.03	2.26	92.5	70	2.5	12.7	3	19.03	7	45	5	60	M8	36	36	M10
3W-15	M12	172	5.14	2.83	121	80	2	12.7	3	19.03	7	56	3	90	M8	36	36	M10
3W-C15	M12	172	5.14	2.83	121	80	2	12.7	3	19.03	7	56	3	90	M8	36	36	M10



- The workpiece compensation of eccentric is 1mm, fixed position for the center, swing and grasp the workpiece to three jaw.
- Second machining can be performed without reversing the workpiece, thus significantly reducing setup time.
- With compensating jaws clamping, the Rough and precision machining can be carried out.
- With sealed design, the maintenance costs can be reduced.
- Can be paired with double-rod rotary cylinder (3RF-D type).
- The driver pin thrust can be controlled by the pressure of the rotary cylinder (3RF-D type).

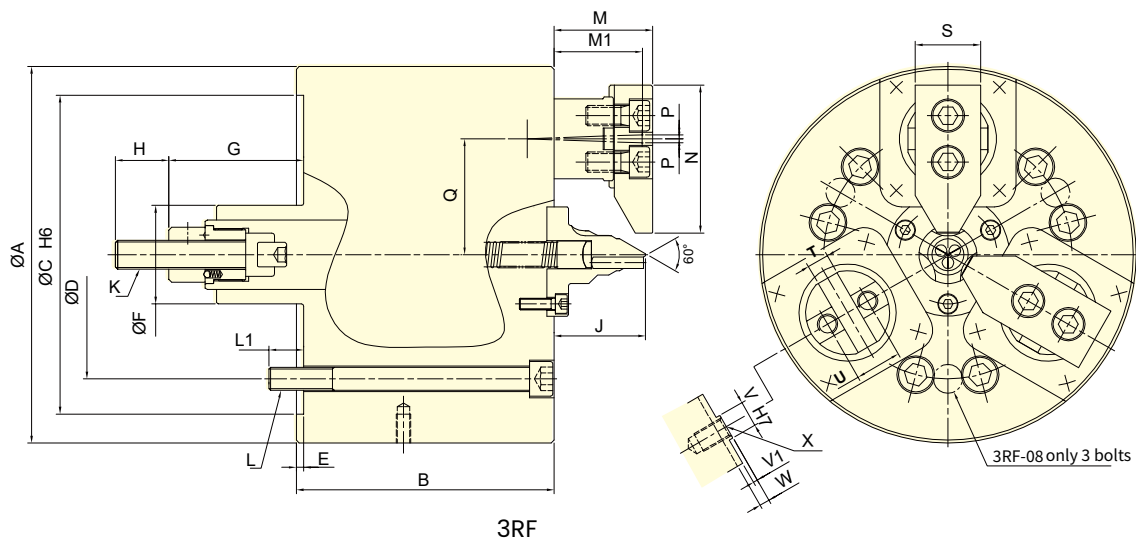

3RF

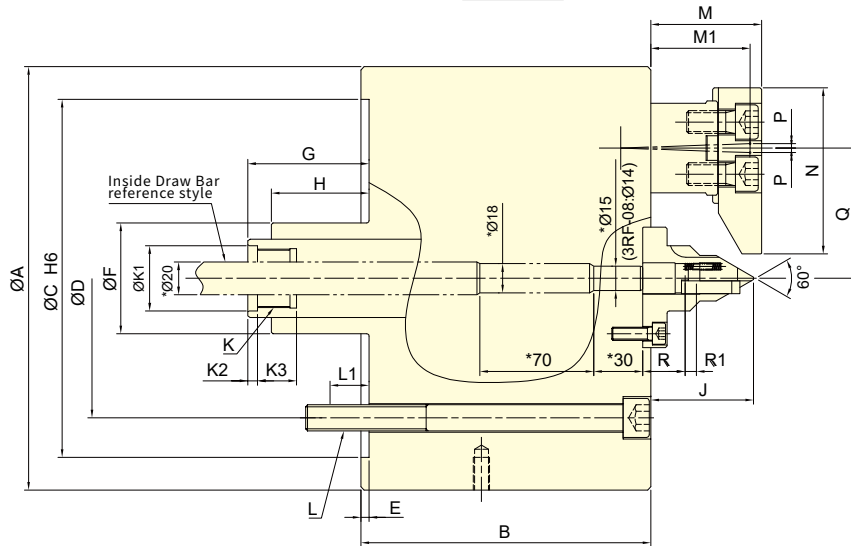

3RF-D

Note: The dimensions marked [*] are the dimensions of the inside Draw Bar , Please don't change it.

Subject to technical changes

SPECIFICATIONS

Model	Chucking Dia.	Jaw stroke (Dia.)	Chucking Dia. Max.	Chucking Dia. Min.	Max. D.B. pull	Max. clamping force	Max. speed	Moment of inertia	Weight	Matching cyl.	Compensation
	mm	mm	mm	mm	kN (kgf)	kN (kgf)	min ⁻¹ (r.p.m.)	kg·m ²	kg		
3RF-08	43.5	9.4	70	18	39.2 (4000)	39.2 (4000)	4000	0.15	39.4	RS-1250	1
3RF-08D	43.5	9.4	70	18	39.2 (4000)	39.2 (4000)	4000	0.15	38.6	RDL-160S	1

Model	Chucking Dia.	Jaw stroke (Dia.)	Chucking Dia. Max.	Chucking Dia. Min.	Max. D.B. pull	Max. clamping force	Max. speed	Moment of inertia	Weight	Matching cyl.	Compensation
	mm	mm	mm	mm	kN (kgf)	kN (kgf)	min ⁻¹ (r.p.m.)	kg·m ²	kg		mm
3RF-10	50	11	85	25	44.1(4500)	67.4(6873)	3500	0.56	68.3	RS-1550	1
3RF-10D	50	11	85	25	44.1(4500)	67.4(6873)	3500	0.56	67.5	RDL-160S	1
3RF-12	52	11.2	110	25	78.4(8000)	99(10000)	2500	0.56	109	RS-2060	1
3RF-12D	52	11.2	110	25	78.4(8000)	99(10000)	2500	0.56	107.7	RDL-160S	1

DIMENSIONS

Model	A	B	C (H6)	D	E	F	G max.	G min.	H	J	K	K1 (H7)	K2	K3	L	L1
3RF-08	210	155	170	133.4	5	68	123	79.5	37	58	M20x2.5	-	-	-	3~M12	18
3RF-08D	210	155	170	133.4	5	68	98	54.5	50	58	M36x1.5	40.5	6	24	3~M12	18
3RF-10	260	178	220	171.4	5	68	143	93	37	63	M20x2.5	-	-	-	6~M16	24
3RF-10D	260	178	220	171.4	5	68	116.5	66.5	60	63	M36x1.5	40.5	6	24	6~M16	26
3RF-12	315	190	220	171.4	5	76	167	115	46	70	M24x3	-	-	-	6~M16	24
3RF-12D	315	190	220	171.4	5	76	135	83	75	70	M40x1.5	44.5	6	28	6~M16	24

Model	M max.	M min.	M1	N	P	Q	R	R1 max.	R1 min.	S	T(H7)	U	V	V1	W	X
3RF-08	62	31	58	78	2.35	62	-	-	-	40	12	26	16	3	7	M12
3RF-08D	62	31	58	78	2.35	62	25.5	7	0	40	12	26	16	3	7	M12
3RF-10	68	35.5	61	102	2.75	80	-	-	-	45	15	32	18	3	7	M14
3RF-10D	68	35.5	61	102	2.75	80	28	7	0	45	15	32	18	3	7	M14
3RF-12	76	43	63	125	2.8	100	-	-	-	50	17	36	20	3	7	M16
3RF-12D	76	43	63	125	2.8	100	28	7	0	50	17	36	20	3	7	M16

APPLICATION NOTES
1. Clamping diameter machining

The compensating jaws are retracted. The workpiece is clamped between chuck center and tailstock center. Additionally, it is driven by the face driver.

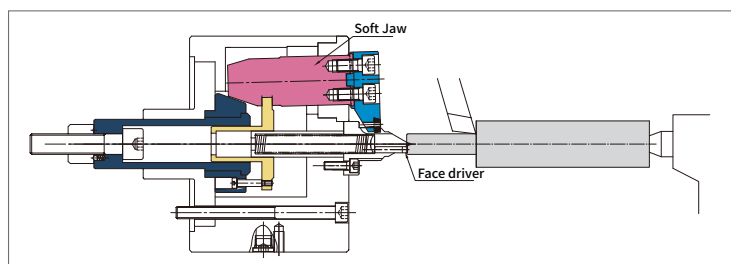
2. Rough machining

With compensating jaws clamping, the rough machining can be carried out.

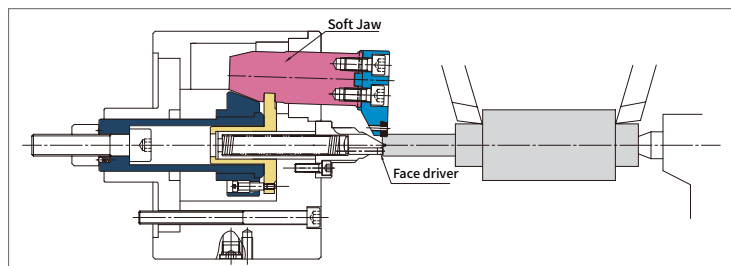

3. Finish machining

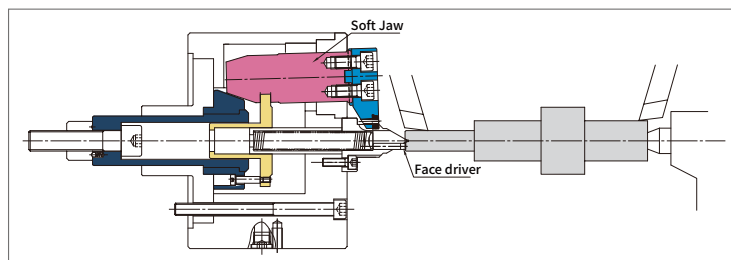
Additionally, it is driven by the face driver. The entire workpiece can be machined with precise concentricity.



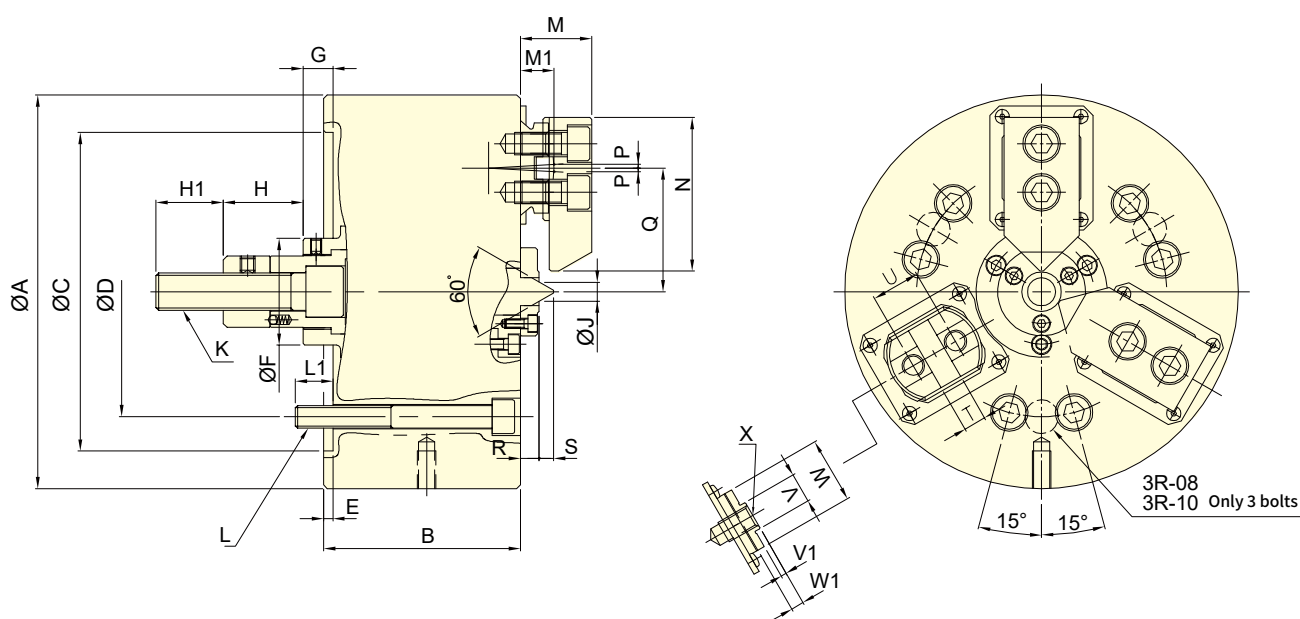

- The workpieces compensation of eccentric is 2 mm, fixed position for the center thimble, swing and grasp the workpiece to three jaw.
- Special seal proof for dust and cutting fluid, it is more convenient when maintenance.
- Swing parts are to heat treatment hardened and ground for steel, in order to improve products service life.



Subject to technical changes

SPECIFICATIONS

Model	Chucking Dia.	Jaw stroke (Dia.)	Chucking Dia. Max.	Chucking Dia. Min.	Max. D.B. pull	Max. clamping force	Max. speed	Moment of inertia	Weight	Matching cyl.	Compensation
	mm	mm	mm	mm	kN (kgf)	kN (kgf)	min ⁻¹ (r.p.m.)	kg·m ²	kg		
3R-08	20	8	65	18	19.6(2000)	53.0(5404)	2800	0.15	27	RK-100N	2
3R-10	25	10	90	22	29.4(3000)	67.7(6901)	2500	0.38	45	RK-125N	2
3R-12	25	10.2	110	22	39.4(4000)	88.4(9010)	2000	0.75	72	RK-150N	2

DIMENSIONS

Model	A	B	C (H6)	D	E	F	G max.	G min.	H	H1	J	K	L	L1
3R-08	210	105	170	133.4	5	57	26	6	42.5	36	10.4	M20x2.5	3~M12	20
3R-10	254	115	220	171.4	5.5	64	36.5	11.5	25	39	15	M20x2.5	3~M16	22.5
3R-12	304	130	220	171.4	5	70	25	0	33	45.5	15	M24x3	3~M16	22

Model	M	M1	N	P	Q max.	Q min.	R	S	T (H7)	U	V	V1	W	W1	X
3R-08	38	18	82	2	68	64	10	7.7	12	26	16	3	35	7	M12
3R-10	40	19	102	2.6	82	78	10	11.3	15	32	18	3	40	7	M14
3R-12	51	24	125	2.5	102.5	97.5	10	11.3	17	36	20	3	50	7	M16

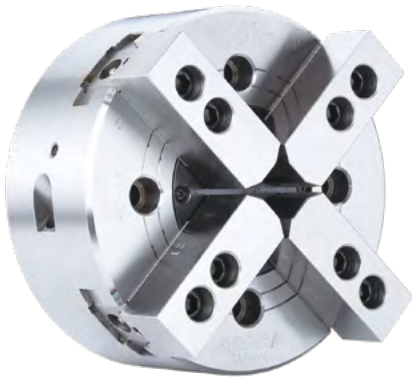

- CRANK type with two pairs of 2 jaws self center independent of each other.
- The 4T series is suitable for square bar and other nonuniform shaped workpieces.

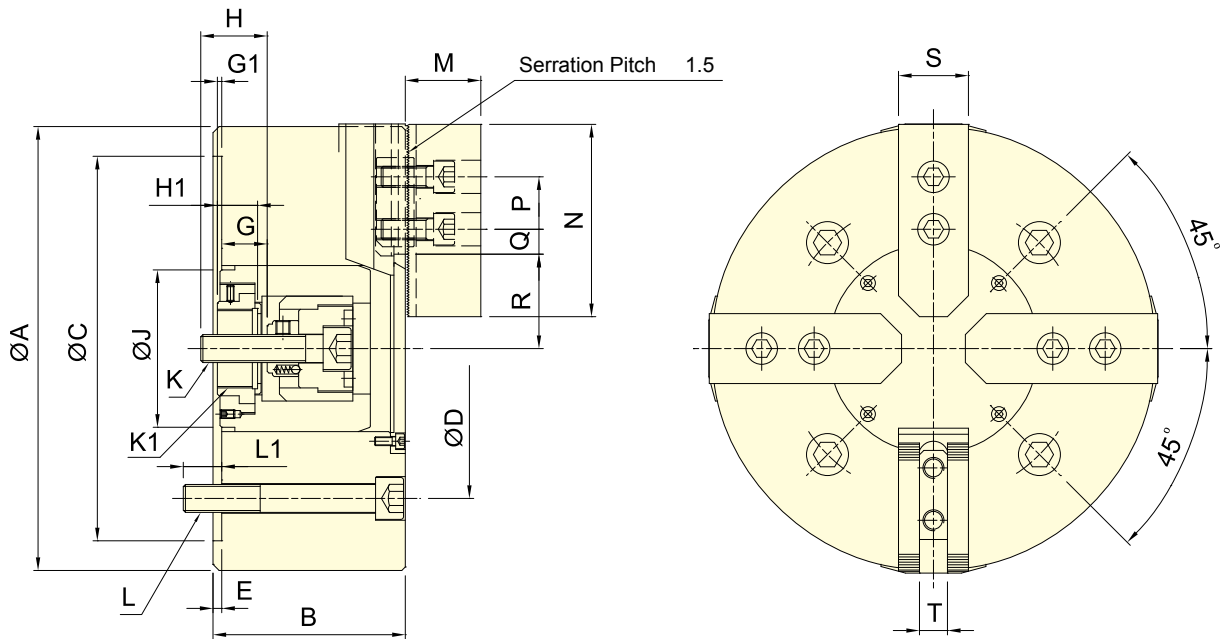

Subject to technical changes

SPECIFICATIONS

Model	Plunger stroke	Jaw stroke (Dia.)	Chucking Dia. Max.	Chucking Dia. Min.	Max. D.B. pull	Max. Clamping force	Max. speed	Moment of inertia	Weight	Matching cyl.	Max. pressure
	mm	mm	mm	mm	kN (kgf)	kN (kgf)	min ⁻¹ (r.p.m.)	kg·m ²	kg		MPa (kgf/cm ²)
4T-08	17	13.6	210	24	16.0 (1630)	54.3 (5540)	3000	0.15	23.2	RD-120(N)	1.7(17)
4T-10	20	16	254	50	21.6 (2200)	79.4 (8100)	2100	0.35	44.3	RD-125(N)	2.2(22)
4T-12	20	16	304	50	21.6 (2200)	79.4 (8100)	1500	0.66	57.6	RD-125(N)	2.2(22)
4T-15	25	19.6	381	60	27.2 (2780)	105.3 (10750)	1200	2.25	118.3	RD-125(N)	2.7(27)

DIMENSIONS

Model	A	B	C(H6)	D	E	G max.	G min.	G1 max.	G1 min.	H	H1	J	K
4T-08	210	91	170	133.4	5	32	15	2.5	-14.5	29	20	61	M14x2
4T-10	254	110	220	171.4	5	36.5	16.5	10	-10	36	23	90	M16x2
4T-12	304	110	220	171.4	5	36.5	16.5	10	-10	36	23	90	M16x2
4T-15	381	135	300	235	6	44.5	19.5	5	-20	45	28	110	M20x2.5

Model	K1	L	L1	M	N	P	Q max.	Q min.	R max.	R min.	S	T
4T-08	M34x1.5	4~M2	20	38	95	25	25.25	13.25	46.1	39.3	35	14
4T-10	M45x1.5	4~M16	25	43	110	30	32.25	12.75	59	51	40	16
4T-12	M45x1.5	4~M16	25	43	110	30	54.75	15.75	59	51	40	16
4T-15	M55x2	4~M20	30	51	130	30	66.5	12.5	78.9	69.1	50	21



- Gripping at the end face and preventing deformation of workpiece.
- Suitable for thin wall workpiece processing.
- The gripping compensating mechanism can grasp the irregular surface workpieces well.
- Airtight pressure detect function is optional.

SPECIAL PURPOSE POWER CHUCKS

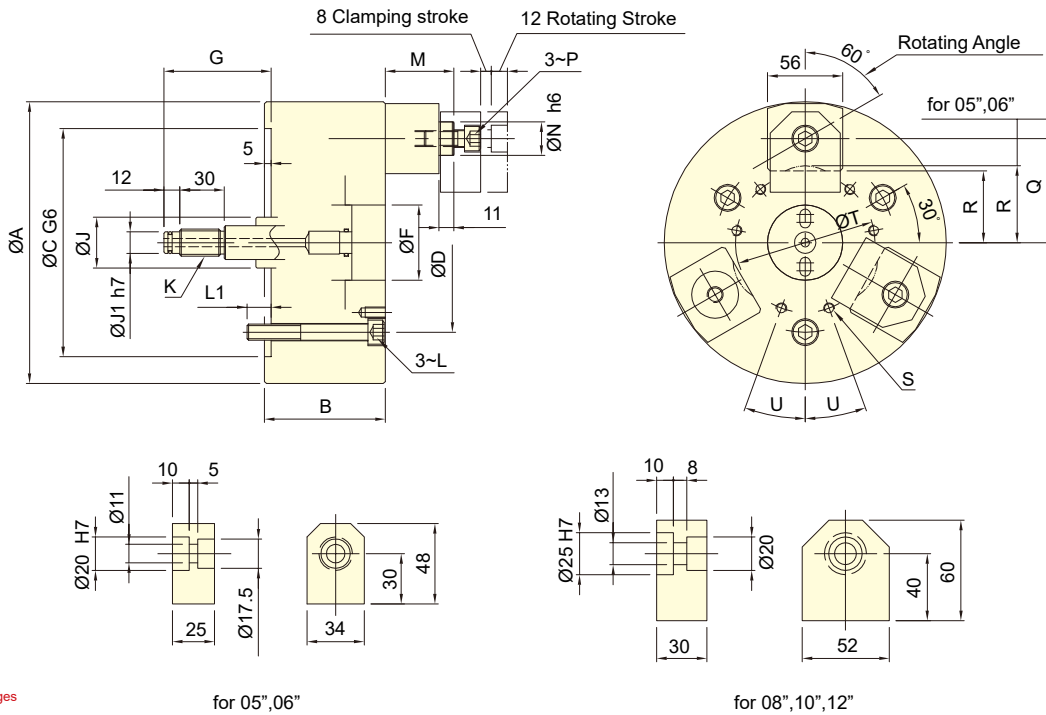

Subject to technical changes

SPECIFICATIONS

Model	Rotating stroke	Clamping stroke	Jaw's compensation	Chucking Dia.Max.	Chucking Dia.Min.	Max. D.B. pull	Max. Clamping force	Max. speed	Moment of inertia	Weight	Matching cyl.	Max. pressure
	mm	mm	mm	mm	mm	kN (kgf)	kN (kgf)	min ⁻¹ (r.p.m.)	kg·m ²	kg		MPa (kgf/cm ²)
3J-05	12	8	2	53	25	7.5(765)	6.0(612)	4000	0.02	11.0	RK-100 OR RK-100(N)	1.0(10)
3J-06	12	8	2	79	55	9.0(918)	7.5(765)	4000	0.04	12.0	RK-100 OR RK-100(N)	1.2(12)
3J-08	12	8	2	106	75	18.0(1835)	16.5(1680)	3500	0.13	23.0	RK-100 OR RK-100(N)	2.5(25)
3J-10	12	8	2.5	150	119	18.0(1835)	16.5(1680)	3500	0.30	33.0	RK-100 OR RK-100(N)	2.5(25)
3J-12	12	8	2.5	200	169	18.0(1835)	16.5(1680)	3000	0.56	44.0	RK-100 OR RK-100(N)	2.5(25)

DIMENSIONS

Model	A	B	C	D	F	G max.	G min.	J	J1	K
3J-05	135	86	110	82.6	40	75	55	25	9	M12x1.75
3J-06	165	86	140	104.8	45	75	55	28	12	M16x2
3J-08	210	90	170	133.4	56	80	60	38	16	M20x2.5
3J-10	254	95	220	171.4	56	75	55	38	16	M20x2.5
3J-12	304	95	220	171.4	56	75	55	38	16	M20x2.5

Model	L	L1	M max.	M min.	N	P	Q	R	S	T	U
3J-05	M10	15	56	36	20	M10	42.5	27	3~M6	50	-
3J-06	M10	15	56	36	20	M10	57.5	40	3~M8	64	-
3J-08	M12	18	71	51	25	M12	77.5	53.5	6~M8	104	20°
3J-10	M16	24	71	51	25	M12	99.5	75.5	6~M8	140	20°
3J-12	M16	24	71	51	25	M12	124.5	100.5	6~M8	190	20°



- Gripping at the end face and preventing deformation of workpiece.
- Suitable for thin wall workpiece processing.
- The gripping compensating mechanism can grasp the irregular surface workpieces well.
- Airtight pressure detect function is optional.

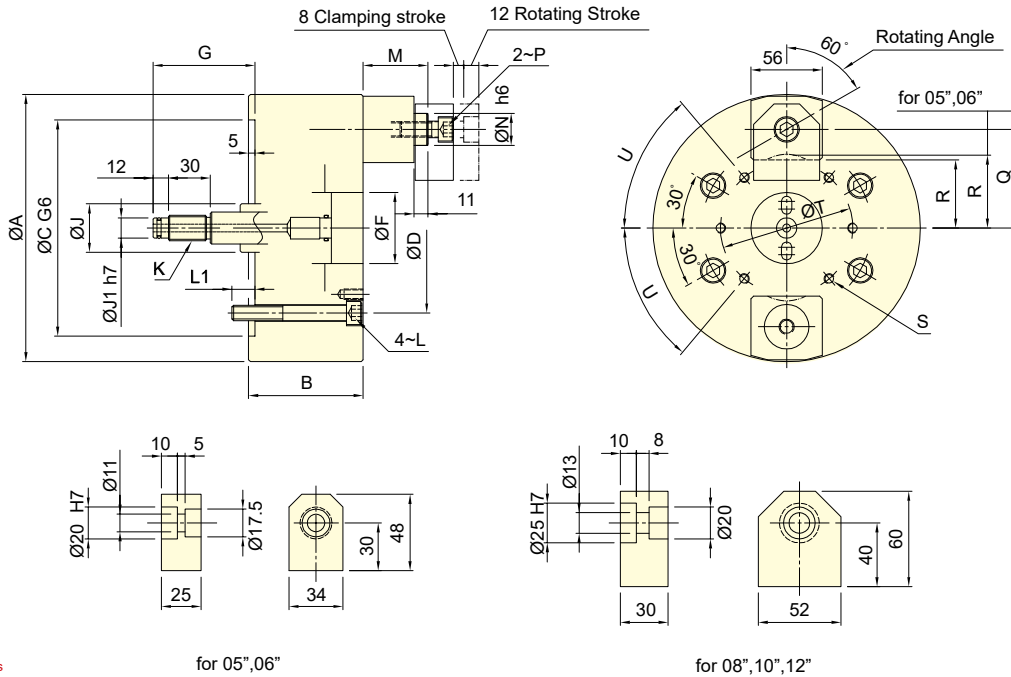

Subject to technical changes

SPECIFICATIONS

Model	Rotating stroke	Clamping stroke	Jaw's compensation	Chucking Dia. Max.	Chucking Dia. Min.	Max. D.B. pull	Max. Clamping force	Max. speed	Moment of inertia	Weight	Matching cyl.	Max. pressure
	mm	mm	mm	mm	mm	kN (kgf)	kN (kgf)	min ⁻¹ (r.p.m.)	kg·m ²	kg		MPa (kgf/cm ²)
2J-05	12	8	2	53	25	5.0(510)	4.0(408)	4000	0.015	9.0	RK-100 OR RK-100(N)	0.7(7)
2J-06	12	8	2	79	55	6.0(612)	5.0(510)	4000	0.035	9.8	RK-100 OR RK-100(N)	0.8(8)
2J-08	12	8	2	106	75	12.0(1224)	11.0(1122)	3500	0.12	20.3	RK-100 OR RK-100(N)	1.7(17)
2J-10	12	8	2.5	150	119	12.0(1224)	11.0(1122)	3500	0.28	30.7	RK-100 OR RK-100(N)	1.7(17)
2J-12	12	8	2.5	200	169	12.0(1224)	11.0(1122)	3000	0.52	41.2	RK-100 OR RK-100(N)	1.7(17)

DIMENSIONS

Model	A	B	C	D	F	G max.	G min.	J	J1	K
2J-05	135	86	110	82.6	40	75	55	25	9	M12x1.75
2J-06	165	86	140	104.8	45	75	55	28	12	M16x2
2J-08	210	90	170	133.4	56	80	60	38	16	M20x2.5
2J-10	254	95	220	171.4	56	75	55	38	16	M20x2.5
2J-12	304	95	220	171.4	56	75	55	38	16	M20x2.5

Model	L	L1	M max.	M min.	N	P	Q	R	S	T	U
2J-05	M10	15	56	36	20	M10	42.5	27	4~M6	50	30°
2J-06	M10	15	56	36	20	M10	57.5	40	4~M8	64	30°
2J-08	M12	18	71	51	25	M12	77.5	53.5	6~M8	104	50°
2J-10	M16	24	71	51	25	M12	99.5	75.5	6~M8	140	50°
2J-12	M16	24	71	51	25	M12	124.5	100.5	6~M8	190	50°

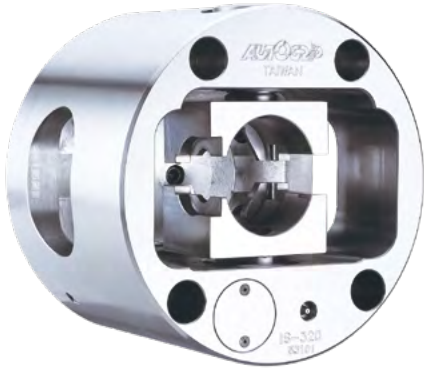

- Indexing operates during the spindle rotation, can perform a quick change between multiple working axes.
- All parts of chuck hardened, ground and lubricated directly.
- Sealed against swarf, chips and coolant.
- High rigidity and high repeatability precision.
- Unique indexing system and hydraulic system, with pressure detection device in chuck, high reliability.

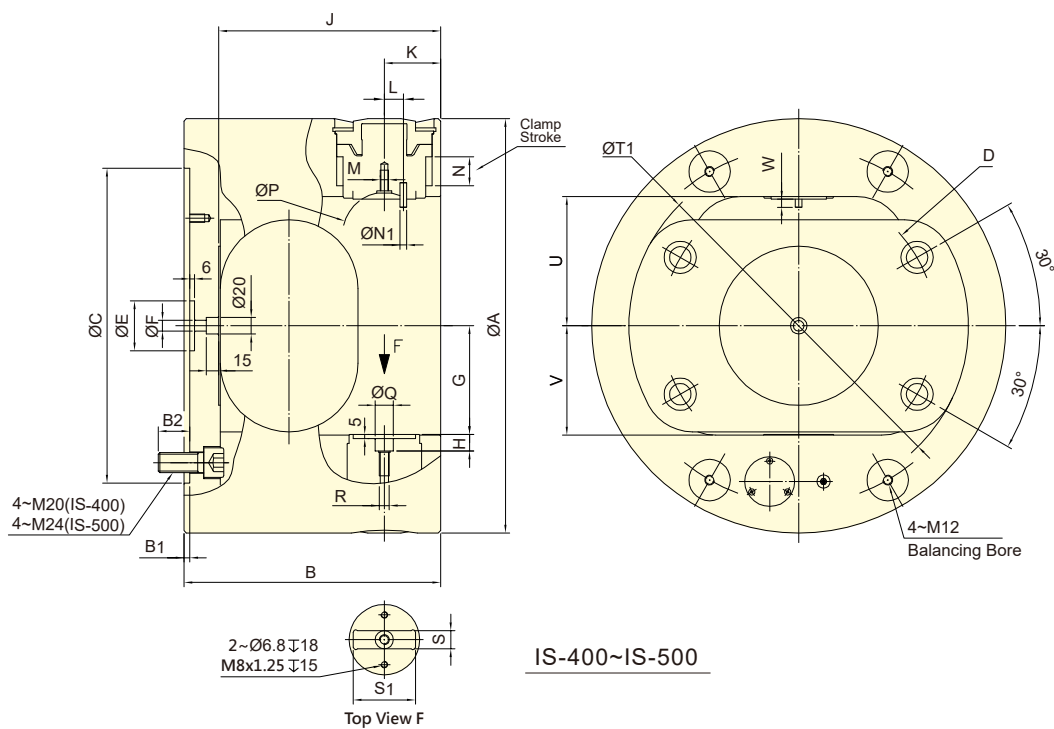
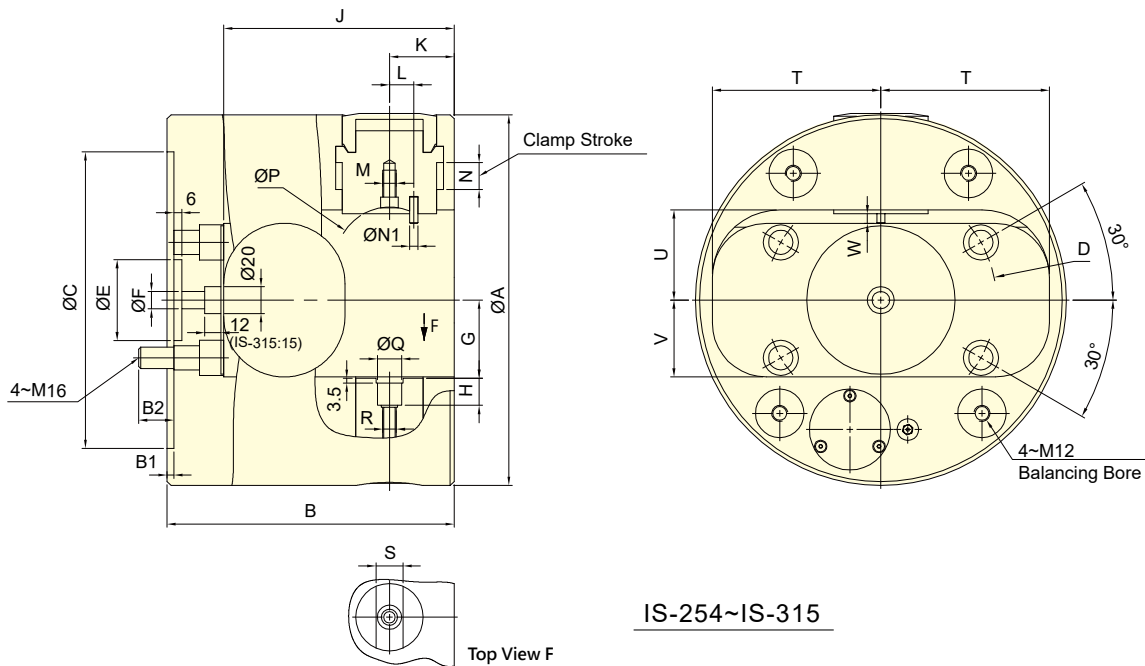

Subject to technical changes

SPECIFICATIONS

Model	Index Angle	Jaw stroke	Chucking Area Dia Max.	Chucking Area Len Max.	Max. pressure	Max. Clamping force	Max. speed	Moment of inertia	Weight	ROTATING JOINT	Main Spindle Bore	Clamp Jaw Weight
	Deg	mm	mm	mm	kgf/cm ²	kN (kgf)	min ⁻¹ (r.p.m.)	kg-m ²	kg		mm	kg
IS-254	4x90°	20	65	160	45	19.5(1990)	3100	0.41	41	IRJ-5E1	⁶¹ and above	0.6
IS-275	4x90°	20	80	220	45	25.4(2590)	2500	0.61	52	IRJ-5E1	⁶¹ and above	1.2
IS-315	4x90°	20	100	230	45	25.0(2550)	1200	1.13	76	IRJ-5E1	⁶¹ and above	1.8
*IS-400	4x90°	30	170	260	45	34.5(3510)	1000	3.4	125	IRJ-5E1	⁶¹ and above	4.0
*IS-500	4x90°	35	220	310	45	45.7(4660)	1000	9.4	220	IRJ-5E1	⁶¹ and above	6.0

DIMENSIONS

Model	A	B	B1	B2	C(H6)	D	E	F	G	H	J	K
IS-254	254	190	5	23	220	171.4	60	13	47.5	18	155	48
IS-275	275	213	5	26	220	171.4	60	13	58	20	171	48
IS-315	315	232	5	22	220	171.4	60	13	71	18.5	187	50
*IS-400	400	260	6	30	300	235	60	13	99	21	220	60
*IS-500	500	308	6	38	380	330.2	60	13	131	21	266	68

Model	L	M	N	N1	P	Q(H7)	R	S(H7)	S1	T	T1	U	V	W
IS-254	13	M8	20	5	40	18	M10	20	-	106	-	57	46.5	5.5
IS-275	18	M10	20	6	80	18	M10	20	-	125	-	67	57	7
IS-315	18	M10	20	6	75	24	M12	25	-	136	-	85	70	7.5
*IS-400	23	M10	30	8	100	22	M12	24	70	-	330	112	100	10
*IS-500	25	M10	35	8	100	22	M12	24	75	-	410	156	132	10



*Index Angle 8x45° or Specific Angle, Please contact AUTOGRIP for more detailed information. Thanks.

The maximum rotational speed can only be achieved when the hydraulic pressure is at its maximum. Additionally, the operating pressure and the weight of the clamping fixture must not exceed the values shown in the table above.

Indexing can be performed while the spindle is rotating. However, when indexing at high rotational speeds, it is recommended to reduce the speed by 50% to avoid vibration caused by imbalance when the workpiece is in an intermediate position. Furthermore, depending on the shape of the workpiece, indexing during spindle rotation may not be possible.

The "*" model is produced upon order, with no stock available.

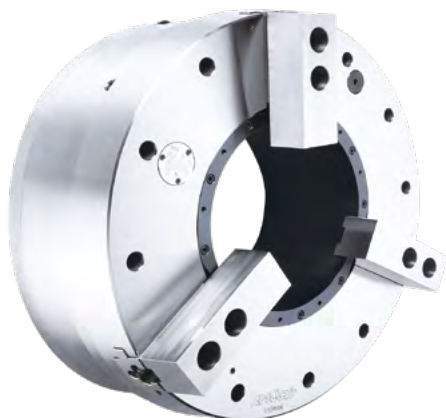

- Large through-hole 3-jaw power chuck with build in air cylinder.
- With build-in "pressure detection" device which can check the rapidly decreasing pressure within the chuck, guarantee to the security when operating.
- Features an air supply system, it is easy to install and maintain. No abrasion issue of traditional sealed ring. Maintenance cost and time can be saved.
- The build-in "clamping detection" device can avoid jaws clamping the workpiece during the rapid stroke stage. This mechanism can also prevent causing the damage of the internal parts or flying out of workpiece.(only for O.D. clamping)
- Extended jaw stroke design can shorten the processing time when gripping.
- Notice:No clamping in rapid stroke period.

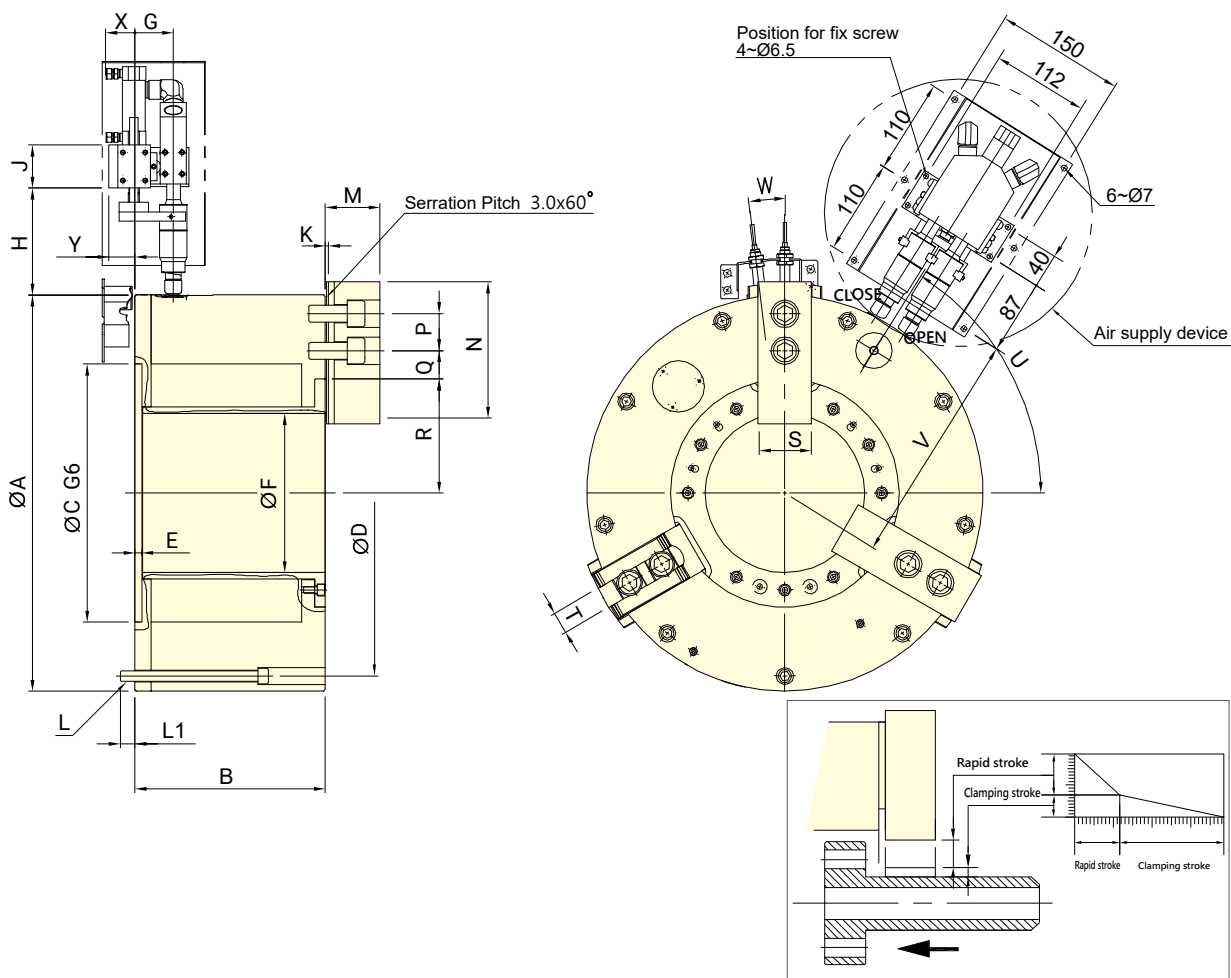

Subject to technical changes

SPECIFICATIONS

Model	Thru-hole Dia.	Jaw stroke (Dia.)		Chucking Dia. Max.	Chucking Dia. Min.	Max. Clamping force kN (kgf)	Max. speed min ⁻¹ (r.p.m.)	Moment of inertia kg·m ²	Weight kg	Air Consumption lit(at 6kgf/cm ²)
	mm	mm	mm	mm						
APS-185	185	26	14	460	127	110(11216)	1300	6.45	198	22

DIMENSIONS

Model	A	B	C	D	E	F	G	H	J	K	L	L1	M
APS-185	460	221	300	425	8	185	45	124	50	3.5	9~M12	17	63.7
Model	N	P	Q max.	Q min.	R max.	R min.	S	T	U	V	W	X	Y
APS-185	165	43	37	17	145	125	62	25.5	58	272	7°	38	30



- Large through-hole 3-jaw pneumatic power chuck with a built-in air cylinder, ideal for pipe and tube machining.
- Equipped with an integrated pressure detection mechanism that monitors sudden pressure drops inside the chuck, ensuring safe operation (Applicable to O.D. gripping only).
- Features an air supply system that allows quick installation and easy maintenance, eliminating wear issues associated with traditional air sealing rings.
- Reduces installation and maintenance costs while minimizing downtime.

SPECIAL PURPOSE POWER CHUCKS

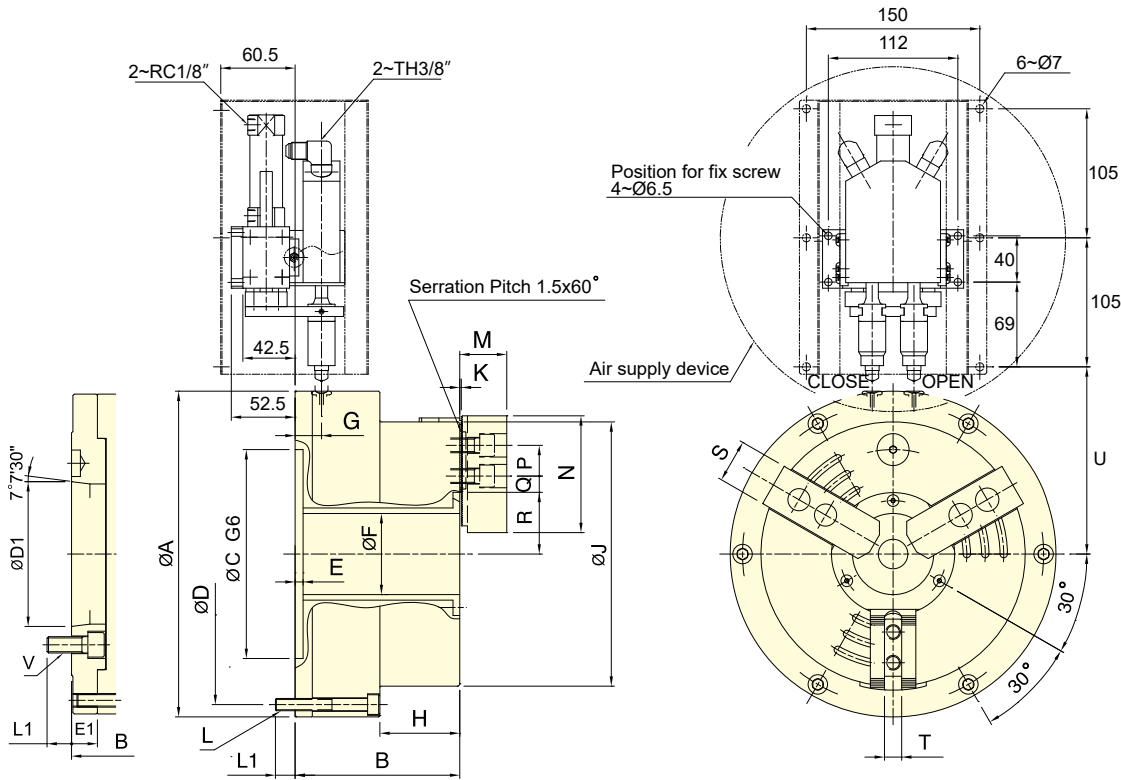

AP-A

Subject to technical changes

SPECIFICATIONS

Model	Thru-hole Dia.	Jaw stroke (Dia.)	Chucking Dia. Max.	Chucking Dia. Min.	Max. pressure	Max. Clamping force	Max. speed	Moment of inertia	Weight	Air Consumption		
	mm	mm	mm	mm	MPa (kgf/cm ²)	kN (kgf)	min ⁻¹ (r.p.m.)	kg·m ²	kg	lit (at 6kgf/cm ²)		
AP-52	A6	52	5.9	170	15	0.6(6.1)	40.5(4128)	3900	0.2	26	30	3.1
AP-66	A6	66	7.6	215	24	0.6(6.1)	50(5097)	3000	0.4	38	45	5.1
AP-86	A8	86	8.9	268	43	0.6(6.1)	80(8156)	2800	0.7	58	72	8.7
AP-115	A8	115	10.6	330	55	0.6(6.1)	90(9174)	2000	1.7	92	112	12

DIMENSIONS

Model	A	B	C	D	D1	E	E1	F	G	H	J	K	L		
AP-52	A6	235	121	140	170	215	106.38	6.5	19	52	21.5	58.5	170	2	6~M10
AP-66	A6	265	134	153	170	245	106.38	6.5	19	66	21.5	65	215	2	6~M10
AP-86	A8	315	142	169	220	295	139.72	6.5	27	86	21.5	67	268	2	6~M10
AP-115	A8	370	154	181	220	350	139.72	6.5	27	115	21.5	69	330	2	6~M10

Model	L1	M	N	P	Q max.	Q min.	R max.	R min.	S	T	U	V		
AP-52	A6	15	18	37	73	20	21.2	9.2	38	35.1	31	12	145.5	6~M12
AP-66	A6	16	18	38	95	25	23.7	8.7	50.2	46.4	35	14	159.5	6~M12
AP-86	A8	16	24	43	110	30	32.2	12.7	62.2	57.8	40	16	184.5	6~M16
AP-115	A8	16	24	51	130	30	44.7	14.7	77	71.7	50	21	212	6~M16

The dimensions and the specifications of AP-A type are in red data.



台灣精品 2018
TAIWAN EXCELLENCE

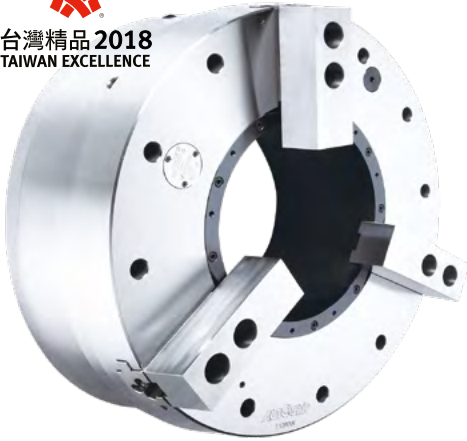

- Large through-hole 3-jaw pneumatic power chuck with a built-in air cylinder, ideal for pipe and tube machining.
- Equipped with an integrated pressure detection mechanism that monitors sudden pressure drops inside the chuck, ensuring safe operation (Applicable to O.D. gripping only).
- Features an air supply system that allows quick installation and easy maintenance, eliminating wear issues associated with traditional air sealing rings.
- Reduces installation and maintenance costs while minimizing downtime.

SPECIAL PURPOSE POWER CHUCKS

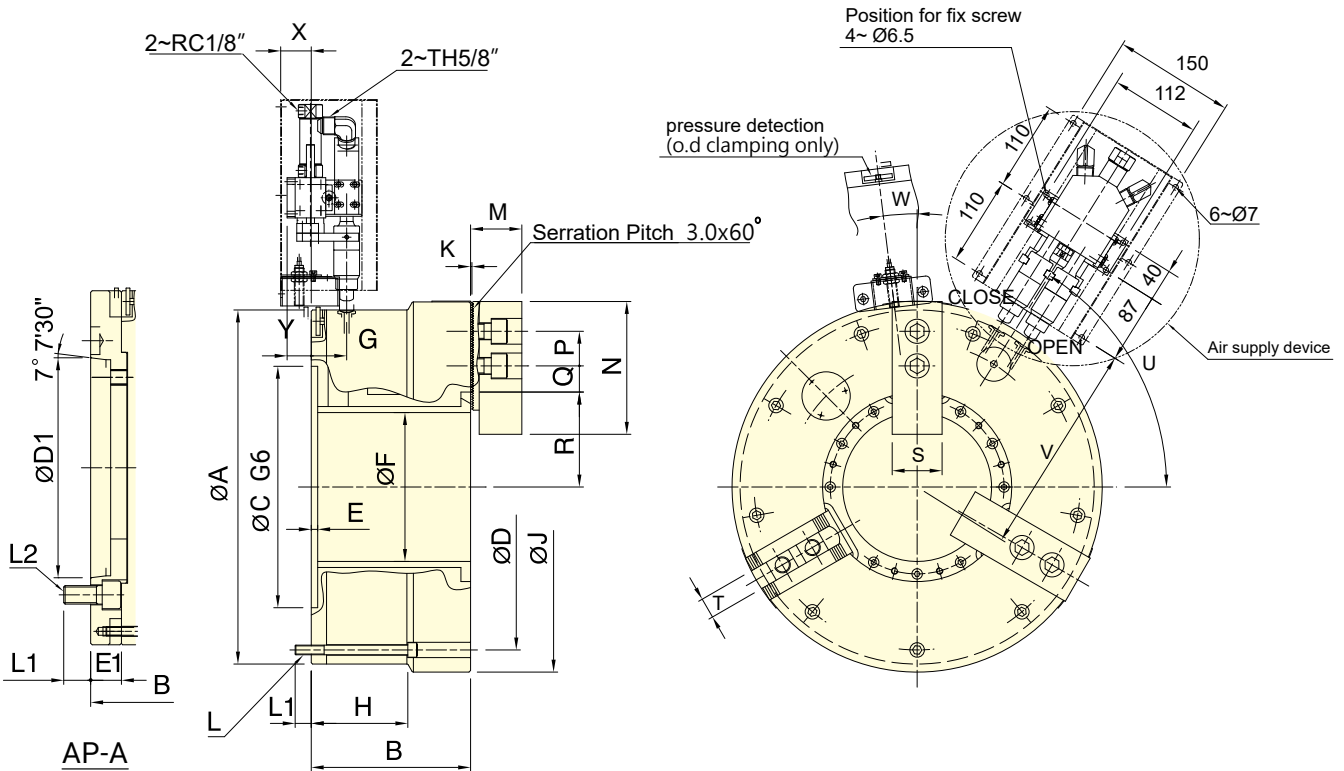

Subject to technical changes

SPECIFICATIONS

Model	Thru-hole Dia.	Jaw stroke (Dia.)	Chucking Dia. Max.	Chucking Dia. Min.	Max. pressure	Max. Clamping force	Max. speed	Moment of inertia	Weight		Air Consumption	
									mm	mm		kg
AP-145	A11	145	14	420	62	0.6(6.1)	110(11213)	1500	3.8	156	182	17.8
AP-185	A15	185	14	460	100	0.6(6.1)	160(16310)	1700	6.0	188	223	22
AP-230	A15	230	17	535	170	0.6(6.1)	150(15290)	1300	11.1	265	310	34
AP-275	A20	275	17	580	200	0.6(6.1)	160(16310)	1100	15.5	301	346	39
AP-320	A20	320	17	658	200	0.6(6.1)	180(18348)	1000	27.2	415	505	45
AP-375	A20	375	24	738	260	0.6(6.1)	210(21406)	900	44.2	530	545	55

The dimensions and the specifications of AP-A type are in red data

DIMENSIONS

Model	A	B	C	D	D1	E	E1	F	G	H	J	K	L	L1			
AP-145	A11	400	198	231	300	365	196.87	8	33	145	34	120	420	3.5	9~M12	20	31
AP-185	A15	460	198	238	300	405	285.78	8	40	185	44	120	460	3.5	9~M12	20	35
AP-230	A15	515	226	266	380	483	285.78	8	40	230	49	145	535	3.5	6~M16	24	35
AP-275	A20	560	232	272	380	528	412.78	8	40	275	52	152	580	3.5	6~M16	24	35
AP-320	A20	615	256	306	520	580	412.78	8	50	320	55	116.5	658	3.5	9~M16	25	33
AP-375	A20	690	272	322	520	650	412.78	8	50	375	55	127	738	3.5	9~M16	28	33

Model	L2	M	N	P	Q max.	Q min.	R max.	R min.	S	T	U	V	W	X	Y	
AP-145	A11	6~M20	63.7	165	43	53.5	23.5	98	91	62	25.5	57°	242	0°	38	20
AP-185	A15	6~M24	63.7	165	43	53.5	23.5	118	111	62	25.5	58°	272	7°	38	20
AP-230	A15	6~M24	71.7	180	60	48.5	18.5	145	136.5	64	25.5	30°	300	7°	33	15
AP-275	A20	6~M24	71.7	180	60	48.5	18.5	167.5	159	64	25.5	30°	322	7°	30	12
AP-320	A20	6~M24	81.5	210	60	60.5	24.5	190	181.5	75	30	52°	350	7°	27	9
AP-375	A20	6~M24	81.5	210	60	66.5	24.5	223.5	211.5	75	30	52°	387	7°	27	9

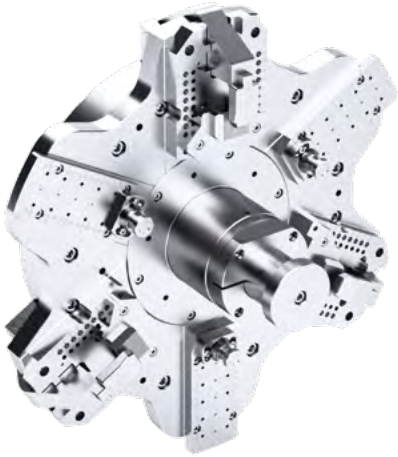

- Made of high-grade alloy steel. All sliding surfaces are surface-hardened and precision-ground to ensure durability and operational stability.
- Designed for rough and finish machining of aluminum alloy wheels for passenger vehicles.
- Accommodates wheel sizes ranging from 13" to 24" by adjusting the support and sealing surfaces, and replacing the drive arms and jaws.
- Changeable fixtures allow adaptation to various centering methods required in different machining processes, enhancing precision and production flexibility.
- Compatible with CNC lathes, dedicated wheel machining machines, and mill-turn centers.
- Optional matching jaws and drive arms available.

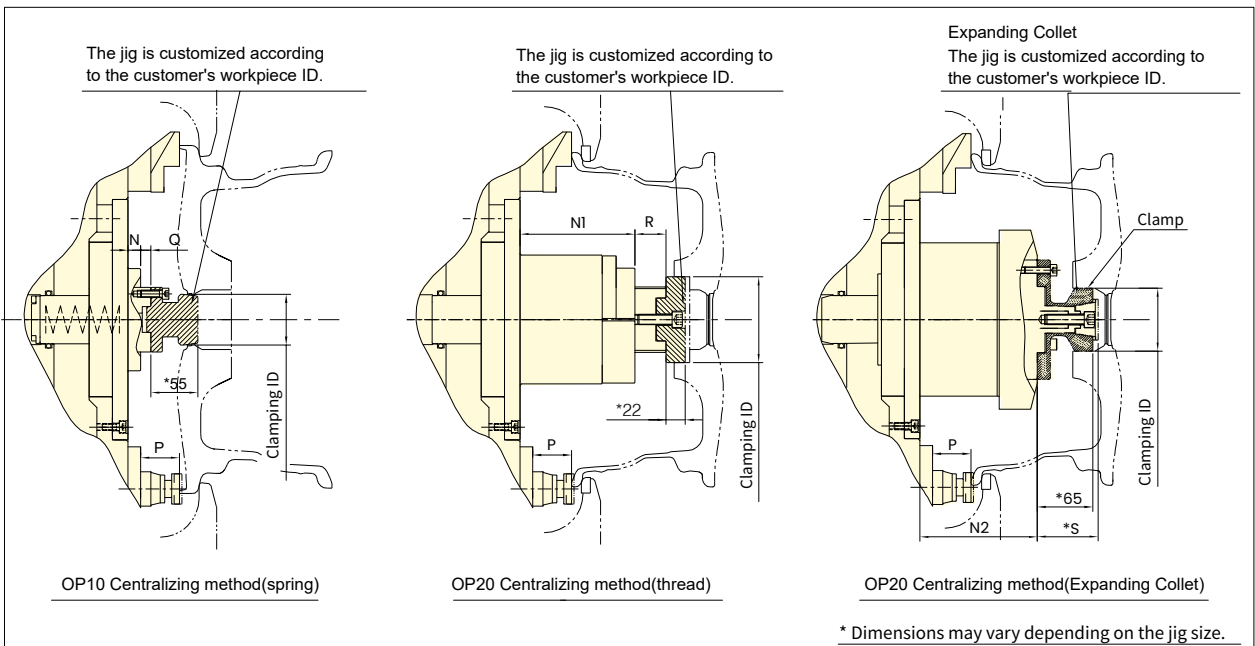
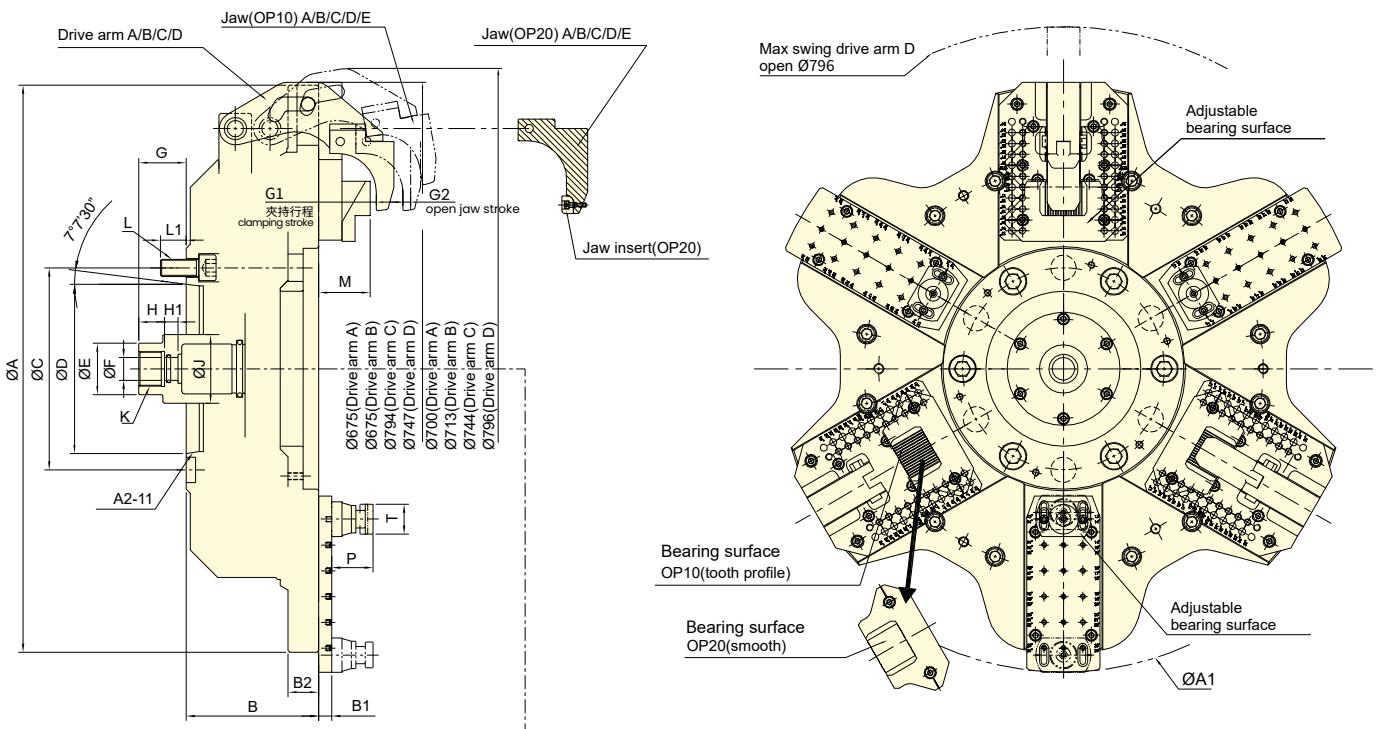

* Dimensions may vary depending on the jig size.

Subject to technical changes

SPECIFICATIONS

Model		Total axial stroke	Open jaw stroke	Clamping stroke	Max. clamping size of the Wheel	Min. clamping size of the Wheel	Max. D.B. pull	Max. clamping force
		mm	mm	mm	inch	inch	kN (kgf)	kN (kgf)
3FW-26	A11	40	9	31	24"	13"	34.3(3500)	30.9(3150)

Model		Max. speed	Moment of inertia	Weight (Jig not included)	Weight (OP10 jig included)	Weight (OP20 jig included)	Matching cyl.	Max. pressure
		min ⁻¹ (r.p.m.)	kg·m ²	kg	kg	kg		MPa kgf/cm ²
3FW-26	A11	2200	7.3	160	180	190~200	RE-A1340	3.2(33)

DIMENSIONS

Model		A	A1	B	B1	B2	C	D	E	F	G max.	G min.	G1	G2	H	H1	J
3FW-26	A11	660	706	154.5	15	36	235	196.87	60	26.5	55	15	31	9	30	15.5	80

Model		K	L	L1	M	N	N1	N2 max.	N2 min.	P max.	P min.	Q max.	Q min.	R max.	R min.	S max.	S min.	T
3FW-26	A11	M40x1.5	6~M20	30	60	15	134	220	38	48	42	15	0	106	32	71.5	66.5	35

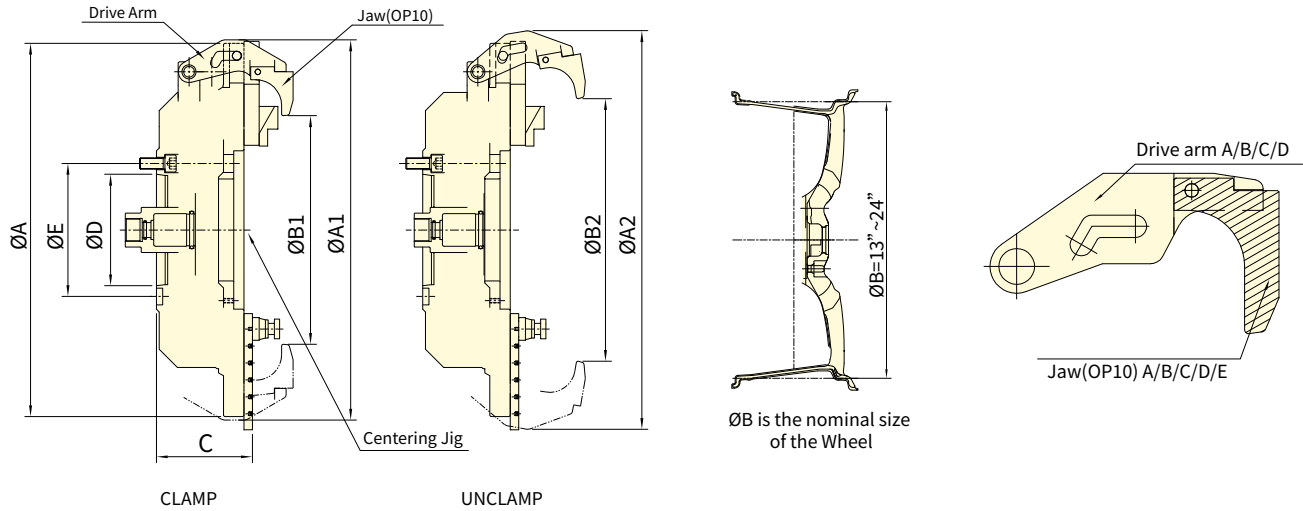

Subject to technical changes

Wheel size	Drive Arm	Drive Arm A		Drive Arm B		Drive Arm C		Drive Arm D	
		Min. ID ØB1	Max. ID ØB2	Min. ID ØB1	Max. ID ØB2	Min. ID ØB1	Max. ID ØB2	Min. ID ØB1	Max. ID ØB2
13"	Jaw A								
	339	400							
14"	Jaw B								
	364	425							
15"	Jaw C								
	392	453							
16"	Jaw D		Jaw A						
	421	482	419	480					
17"	Jaw E		Jaw B						
	445	506	444	505					
18"			Jaw C		Jaw A				
			472	533	477	538			
19"			Jaw D		Jaw B				
			501	502	502	563			
20"			Jaw E		Jaw C		Jaw A		
			525	586	530	591	530	591	
21"					Jaw D		Jaw B		
					559	620	555	616	
22"					Jaw E		Jaw C		
					583	644	583	644	
23"							Jaw D		
							607	668	
24"							Jaw E		
							633	694	
Max. chuck diameter ØA	Ø660								
Max. OD when CLAMP ØA1	Ø675		Ø675		Ø694		Ø747		
Max. OD when UNCLAMP ØA2	Ø700		Ø713		Ø744		Ø796		
Wheel size ØB	13"~17"		16"~20"		18"~22"		20"~24"		
C	169.5								
ØD	196.87								
ØE	235								

Blocks in the same color indicate that different combinations of drive arms and jaws can be used to clamp wheels of the same size. The selection depends on the available space of the machine.
 For example: Drive Arm A + Jaw D = clamping a 16" wheel, and Drive Arm B + Jaw A can also clamp a 16" wheel.

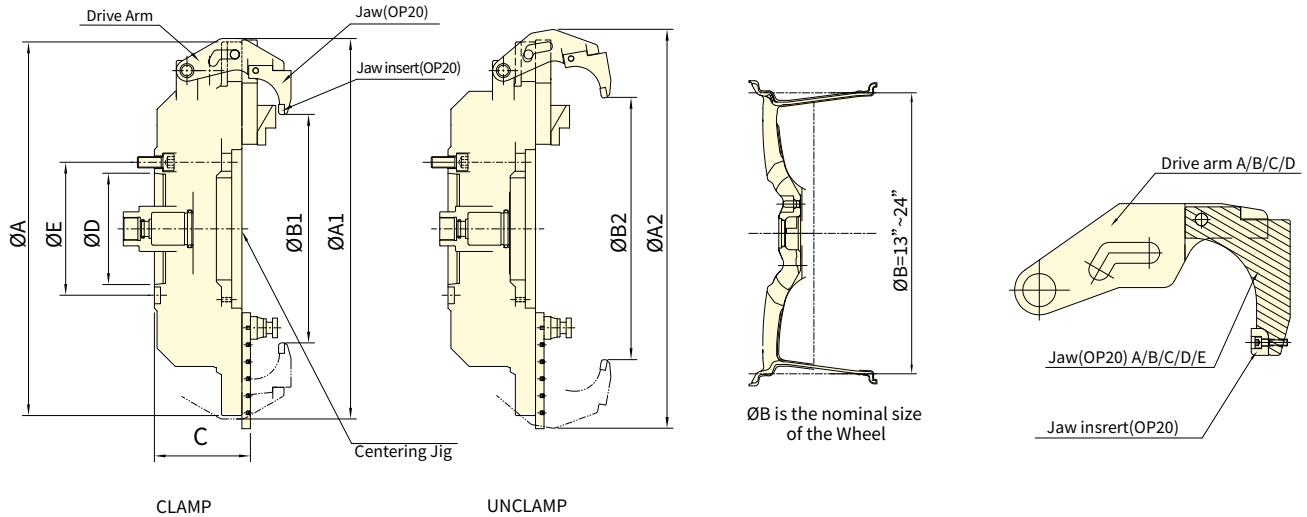

SPECIAL PURPOSE POWER CHUCKS

Subject to technical changes

Wheel size \ Drive Arm	Drive Arm A		Drive Arm B		Drive Arm C		Drive Arm D	
	Min. ID ØB1	Max. ID ØB2	Min. ID ØB1	Max. ID ØB2	Min. ID ØB1	Max. ID ØB2	Min. ID ØB1	Max. ID ØB2
13"	Jaw A							
	335	396						
14"	Jaw B							
	362	423						
15"	Jaw C							
	392	453						
16"	Jaw D		Jaw A					
	417	478	415	476				
17"	Jaw E		Jaw B					
	445	506	442	503				
18"			Jaw C		Jaw A			
			472	553	473	534		
19"			Jaw D		Jaw B			
			497	558	500	561		
20"			Jaw E		Jaw C		Jaw A	
			525	586	530	591	526	587
21"					Jaw D		Jaw B	
					555	616	553	614
22"					Jaw E		Jaw C	
					583	644	583	644
23"							Jaw D	
							603	664
24"							Jaw E	
							633	694
Max. chuck diameter ØA	Ø660							
Max. OD when CLAMP ØA1	Ø675		Ø675		Ø694		Ø747	
Max. OD when UNCLAMP ØA2	Ø700		Ø713		Ø744		Ø796	
Wheel size ØB	13"~17"		16"~20"		18"~22"		20"~24"	
C	169.5							
ØD	196.87							
ØE	235							

Blocks in the same color indicate that different combinations of drive arms and jaws can be used to clamp wheels of the same size. The selection depends on the available space of the machine. For example: Drive Arm A + Jaw D = clamping a 16" wheel, and Drive Arm B + Jaw A can also clamp a 16" wheel.