

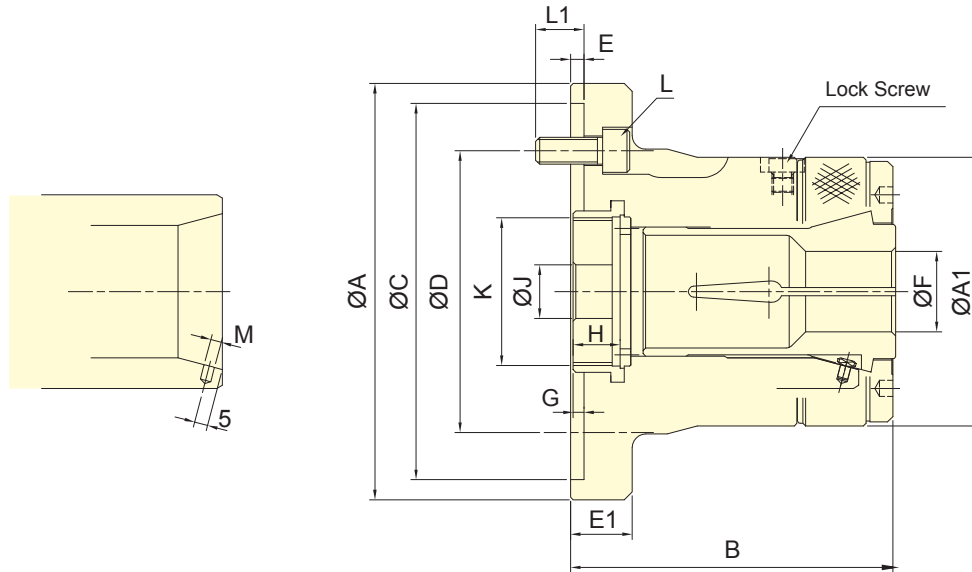

- PUSH type collet used mainly on turning, CNC, special purpose machines , ect.
- High clamping accuracy, high speed and high rigidity.
- Sealed against swarf, chips and coolant.
- The collet used must accord with DIN 6343.
- Patent numbers :  
 PAT.NO.M380842(Taiwan)  
 PAT.NO.ZL201020113762.X(China)



Subject to technical changes

## SPECIFICATIONS

Model	Plunger stroke mm	Max. Chucking Capacity			Max. D.B. pull kN (kgf)	Max. clamping force kN (kgf)	Max. speed min <sup>-1</sup> (r.p.m.)	Moment of inertia kg · m <sup>2</sup>	Weight kg	Matching steel collet	Matching Cyl.	Max. pressure MPa (kgf/cm <sup>2</sup> )
		Round mm	Hexagom mm	Square mm								
CL-26	4.5	3~26	4~22	4~18	17.6(1800)	37.9(3870)	8000	0.040	4.3	161E	TK-A533	2.4(24)
CL-30	4.5	3~30	4~26	4~20	19.6(2000)	42.1(4300)	8000	0.038	4.2	163E	TK-A533	2.7(27)
CL-36	6	3~36	6~32	6~26	22.5(2300)	48.5(4950)	6000	0.062	7.0	171E	TK-C643	2.3(23)
CL-42	6	3~42	6~36	6~29	24.5(2500)	52.9(5400)	6000	0.060	6.9	173E	TK-C643	2.5(25)
CL-52	6	5~52	8~45	7~36	27.4(2800)	59.0(6020)	6000	0.101	14.3	177E	TK-A853	2.0(20)
CL-6017	6	5~60	8~52	7~42	29.4(3000)	63.7(6500)	5000	0.098	14.1	185E	TS-866	1.8(18)
CL-6022	6	5~60	8~52	7~42	29.4(3000)	63.7(6500)	5000	0.126	16.3	185E	TS-866	1.8(18)
CL-80	6	20~80	18~69	15~56	34.3(3500)	71.5(7300)	4000	0.108	17.8	193E	TK-A1287	1.6(16)

## DIMENSIONS

Model	A	A1	B	C(H6)	D	E	E1	F max.	F min.	G max.	G min.	H	J	K max.	L	L1	M
CL-26	120	85	100	110	82.6	4	23	26	3	7	2.5	15	12	M40x1.5	3~M10x25	16	4
CL-30	120	85	100	110	82.6	4	23	30	3	7	2.5	15	12	M40x1.5	3~M10x25	16	4
CL-36	155	100	120	140	104.8	5	23	36	3	7	1	17.5	20	M55x2	3~M10x25	18	4
CL-42	155	100	120	140	104.8	5	23	42	3	7	1	17.5	20	M55x2	3~M10x25	18	4
CL-52	185	130	145.5	170	133.4	5	27	52	5	9	3	24	30	M60x2	6~M12x30	20	5
CL-6017	185	130	145.5	170	133.4	5	27	60	5	9	3	24	45	M75x2	6~M12x30	20	5
CL-6022	234	130	142	220	171.4	5	32	60	5	13	7	24	45	M85x2	6~M16x30	20	5
CL-80	234	156	163	220	171.4	5	32	80	20	15.5	9.5	22	45	M100x2	6~M16x30	20	5



- PUSH type collet used mainly on turning, CNC, special purpose machines , ect.
- High clamping accuracy, high speed and high rigidity.
- Sealed against swarf, chips and coolant.
- The collet used must accord with DIN 6343.
- Patent numbers :  
 PAT.NO.M380842(Taiwan)  
 PAT.NO.ZL201020113762.X(China)

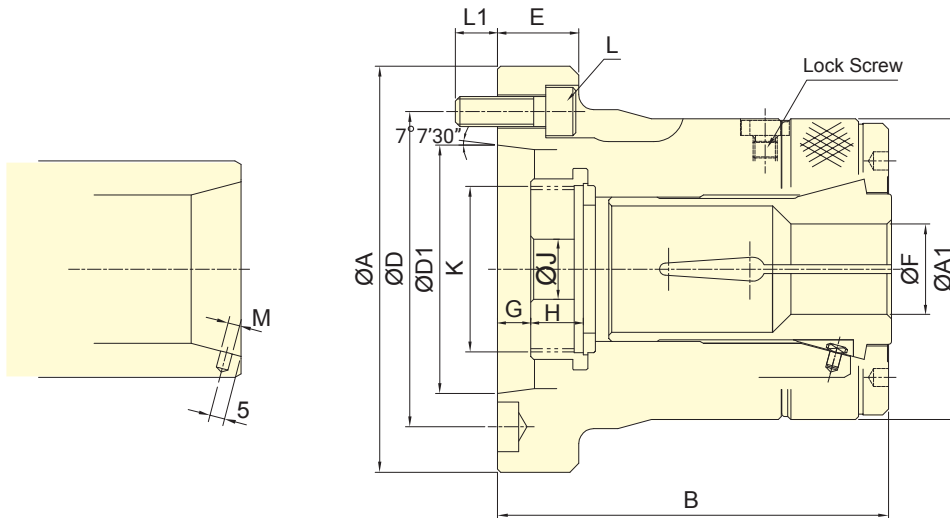

Subject to technical changes

## SPECIFICATIONS

Model	Plunger stroke mm	Max. Chucking Capacity			Max. D.B. pull kN (kgf)	Max. clamping force kN (kgf)	Max. speed min <sup>-1</sup> (r.p.m.)	Moment of inertia kg · m <sup>2</sup>	Weight kg	Matching steel collet	Matching Cyl.	Max. pressure MPa (kgf/cm <sup>2</sup> )	
		Round mm	Hexagom mm	Square mm									
CL-26	A4	4.5	3~26	4~22	4~18	17.6(1800)	37.9(3870)	8000	0.040	4.2	161E	TK-A533	2.4(24)
CL-30	A4	4.5	3~30	4~26	4~20	19.6(2000)	42.1(4300)	8000	0.038	4.1	163E	TK-A533	2.7(27)
CL-36	A5	6	3~36	6~32	6~26	22.5(2300)	48.5(4950)	6000	0.058	6.3	171E	TK-C643	2.3(23)
CL-42	A5	6	3~42	6~36	6~29	24.5(2500)	52.9(5400)	6000	0.057	6.1	173E	TK-C643	2.5(25)
CL-42	A6	6	3~42	6~36	6~29	24.5(2500)	52.9(5400)	6000	0.061	7.5	173E	TK-C643	2.5(25)
CL-52	A6	6	5~52	8~45	7~36	27.4(2800)	59.0(6020)	6000	0.093	13.8	177E	TK-A853	2.0(20)
CL-60	A6	6	5~60	8~52	7~42	29.4(3000)	63.7(6500)	5000	0.091	13.5	185E	TS-866	1.8(18)
CL-60	A8	6	5~60	8~52	7~42	29.4(3000)	63.7(6500)	5000	0.104	14.5	185E	TS-866	1.8(18)
CL-80	A8	6	20~80	18~69	15~56	34.3(3500)	71.5(7300)	4000	0.120	19.8	193E	TK-A1287	1.6(16)

## DIMENSIONS

Model	A	A1	B	D	D1	E	F max.	F min.	G max.	G min.	H	J	K max.	L	L1	M	
CL-26	A4	110	85	108	82.6	63.51	25	26	3	9.5	5	15	12	M40x1.5	3~M10x30	15	4
CL-30	A4	110	85	108	82.6	63.51	25	30	3	9.5	5	15	12	M40x1.5	3~M10x30	15	4
CL-36	A5	135	100	130	104.8	82.56	27	36	3	14	8	17.5	20	M55x2	4~M10x30	14	4
CL-42	A5	135	100	130	104.8	82.56	27	42	3	14	8	17.5	20	M55x2	4~M10x30	14	4
CL-42	A6	165	100	130	133.4	106.38	32	42	3	15	9	17.5	20	M60x2	4~M12x35	16	4
CL-52	A6	170	130	154	133.4	106.38	27	52	5	10.5	4.5	24	45	M60x2	4~M12x35	20	5
CL-60	A6	170	130	154	133.4	106.38	27	60	5	10.5	4.5	24	45	M75x2	4~M12x35	20	5
CL-60	A8	210	130	147.5	171.4	139.72	35	60	5	3.5	-2.5	24	45	M85x2	4~M16x40	22	5
CL-80	A8	210	156	175	171.4	139.72	35	80	20	7.5	1.5	22	45	M100x2	6~M16x40	22	5

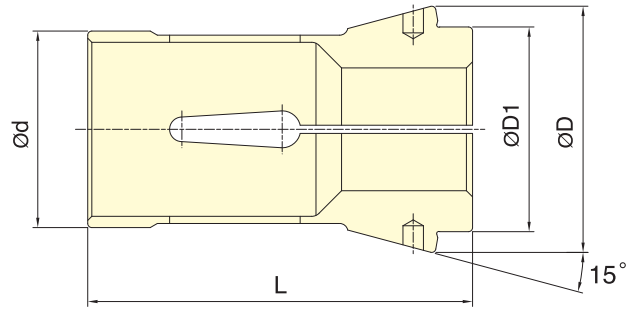
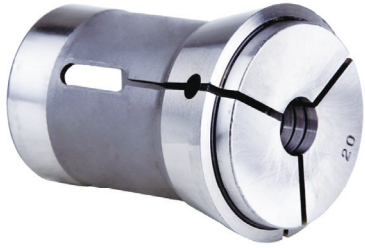

DIN 6343 Collet standard

Subject to technical changes

**DIMENSIONS**

Collet	Max. Chucking Capacity (mm)			d	D	D1	L	Matching Collet Chuck
	Round	Hexagom	Square					
<b>161E</b>	3~26	4~22	4~18	32	45	34	75	CL-26, CL-26A4
<b>163E</b>	3~30	4~26	4~20	35	48	38	80	CL-30, CL-30A4
<b>171E</b>	3~36	6~32	6~26	42	55	42	94	CL-36, CL-36A5
<b>173E</b>	3~42	6~36	6~29	48	60	50	94	CL-42, CL-42A5, CL-42A6
<b>177E</b>	5~52	8~45	7~36	58	70	60	94	CL-52, CL-52A6
<b>185E</b>	5~60	8~52	7~42	66	84	73	110	CL-6017, CL-6022, CL-60A6, CL-60A8
<b>193E</b>	20~80	18~69	15~56	90	107	92	130	CL-80, CL-80A8

Test Bar D(S,H)	L mm	A DIN	
		Class 1	Class 2
0.5~1.0	3	0.015	0.015
1.0~1.6	6	0.015	0.020
1.6~3.0	10	0.015	0.020
3.0~6.0	16	0.015	0.020
6.0~10.0	25	0.015	0.020
10.0~18.0	40	0.020	0.030
18.0~24.0	50	0.020	0.030
24.0~30.0	60	0.020	0.030
30.0~50.0	80	0.030	0.040
50.0~60.0	100	0.030	0.040

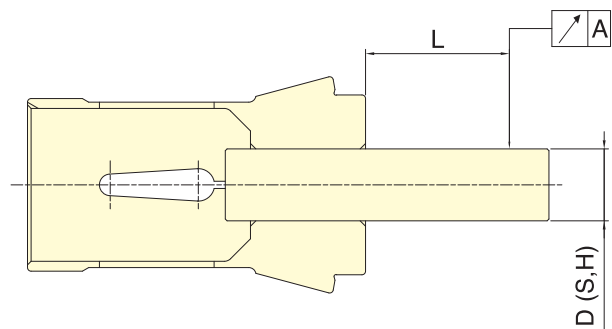

Note: Collets chuck are conformed to DIN 6343 Class2.



- Suitable for CNC lathes, dedicated machines, or other turning machinery for bar or shaft processing.
- Draw-back clamping with radial clamping and axial fine-tuning torque, featuring through-hole.
- High precision, high speed, and high rigidity structure.
- Comprehensive waterproof design to prevent cutting water from entering the spindle through holes.
- J is the hole diameter of blank draw nut.  
K is the maximum thread specification and it could be customize.

COLLET CHUCKS

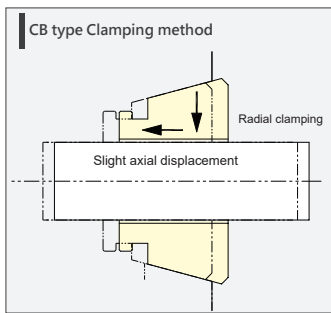

During clamping, the workpiece shifts slightly backward along with the collet.

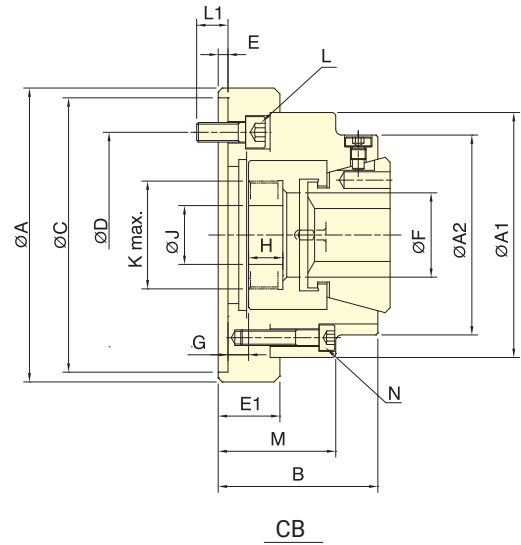
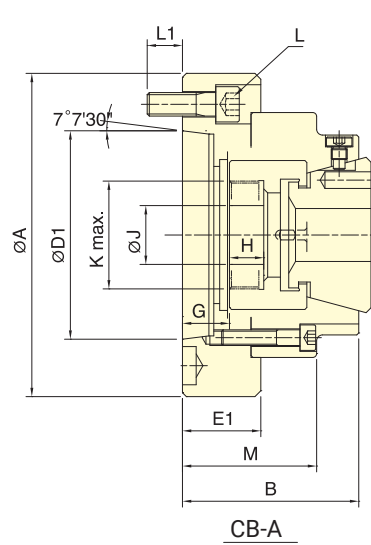

Subject to technical changes

### SPECIFICATIONS

Model	Plunger stroke	Max. Chucking Capacity			Max. D.B. pull	Max. clamping force	Max. speed	Weight	Matching steel collet	Matching Cyl.	Max. pressure
		Round	Hexagom	Square							
	mm	mm	mm	mm	kN (kgf)	kN (kgf)	min <sup>-1</sup> (r.p.m.)	kg			MPa (kgf/cm <sup>2</sup> )
CB-42	4.5	4~42	7~36	7~30	34.3(3500)	78.4(8000)	7000	6.5	RG-42	TK-B846	2.8(28)
CB-42 A5	4.5	4~42	7~36	7~30	34.3(3500)	78.4(8000)	7000	6.2	RG-42	TK-B846	2.8(28)
CB-42 A6	4.5	4~42	7~36	7~30	34.3(3500)	78.4(8000)	7000	7.4	RG-42	TK-B846	2.8(28)
CB-52	4.5	4~52	7~36	7~45	39.2(4000)	92.1(9400)	7000	6	RG-52	TK-A853	3.2(32)
CB-5217	4.5	4~52	7~36	7~45	39.2(4000)	92.1(9400)	7000	9.6	RG-52	TK-A853	3.2(32)
CB-52 A5	4.5	4~52	7~36	7~45	39.2(4000)	92.1(9400)	7000	6.5	RG-52	TK-A853	3.2(32)
CB-52 A6	4.5	4~52	7~36	7~45	39.2(4000)	92.1(9400)	7000	7.8	RG-52	TK-A853	3.2(32)
CB-65	4.5	4~65	8~56	8~46	44.1(4500)	103(10500)	5500	15	RG-65	TS-866	3.0(30)
CB-65 A6	4.5	4~65	8~56	8~46	44.1(4500)	103(10500)	5500	13.6	RG-65	TS-866	3.0(30)
CB-65 A8	4.5	4~65	8~56	8~46	44.1(4500)	103(10500)	5500	17.6	RG-65	TS-866	3.0(30)
CB-80	4.5	5~80	8~68	8~56	50.0(5100)	115(11730)	5500	19	RG-80	TK-A1287	2.3(23)
CB-80 A8	4.5	5~80	8~68	8~56	50.0(5100)	115(11730)	5500	19	RG-80	TK-A1287	2.3(23)

### DIMENSIONS

Model	A	A1	A2	B	C(H6)	D	D1	E	E1	F	G max.	G min.	H	J	K max.	L	L1	M	N
CB-42	150	125	102	81.5	140	104.8	-	5	31	43	10.5	6	17.5	30	M55x2	3~M10x25	11	60	4~M8
CB-42 A5	140	125	102	91.5	-	104.8	82.56	-	41.5	43	25.5	21	17.5	30	M55x2	4~M10x25	12	70	4~M8
CB-42 A6	165	125	102	91.5	-	133.4	106.38	-	45	43	29	24.5	17.5	30	M55x2	4~M12x35	18	73.5	4~M8
CB-52	150	125	102	83.5	140	104.8	-	5	31.5	53	11	6.5	17.5	30	M60x2	4~M10x25	16	62.5	4~M8
CB-5217	180	125	102	87	170	133.4	-	5	35	53	14.5	10	17.5	30	M60x2	4~M12x30	18	66	4~M8
CB-52 A5	140	125	102	93.5	-	104.8	82.56	-	41.5	53	26	21.5	17.5	30	M60x2	4~M10x30	16	72.5	4~M8
CB-52 A6	165	125	102	99	-	133.4	106.38	-	47	53	31.5	27	17.5	30	M60x2	6~M12x35	18	78	4~M8
CB-65	185	145	120	100	170	133.4	-	6	50	66	13.5	9	21.5	32	M75x2	6~M12x40	20	73.5	4~M8
CB-65 A6	165	145	120	111	-	133.4	106.38	-	61	66	30.5	26	21.5	32	M75x2	4~M12x40	20	84.5	4~M8
CB-65 A8	207	145	120	107	-	171.4	139.72	-	57	66	26.5	22	21.5	32	M75x2	4~M16x40	24	80.5	4~M8
CB-80	235	175	150	112	220	171.4	-	5	37	82.5	13.5	8	25	45	M85x2	6~M16x30	22	87	6~M10
CB-80 A8	210	175	150	125	-	171.4	139.72	-	50	82.5	26.5	21	25	45	M85x2	6~M16x50	24	100	6~M10



- The pull-back positioning clamping, combined with the workpiece stop block mechanism, features radial clamping and axial fine-tuning torque, enabling precise positioning of the workpiece feeding length for enhanced length accuracy control.
- The material stopper and dust cover can be interchanged for combined use, providing chip prevention functionality.
- J is the hole diameter of blank draw nut.  
K is the maximum thread specification and it could be customize.

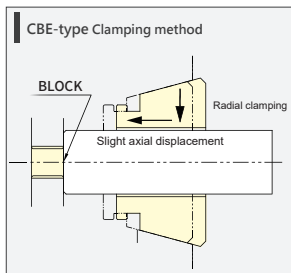

With the material stop mechanism in place, the workpiece does not shift backward during clamping, although there may be slight scuff marks on the surface.

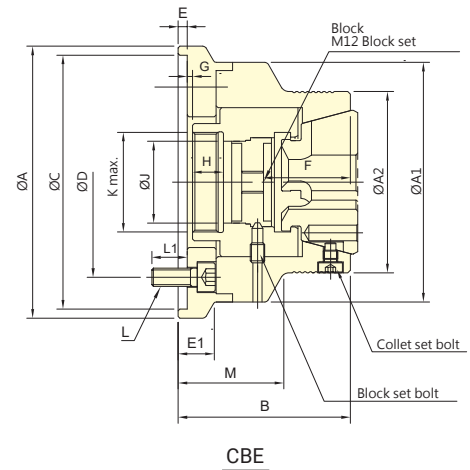
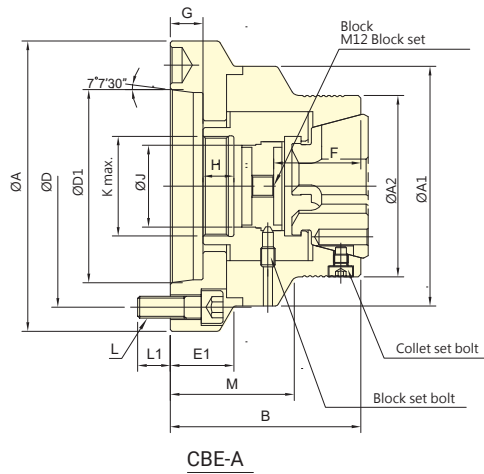

Subject to technical changes

## SPECIFICATIONS

Model	Plunger stroke mm	Max. Chucking Capacity			Max. D.B. pull kN (kgf)	Max. clamping force kN (kgf)	Max. speed min <sup>-1</sup> (r.p.m.)	Weight kg	Matching steel collet	Matching Cyl.	Max. pressure MPa (kgf/cm <sup>2</sup> )
		Round mm	Hexagom mm	Square mm							
<b>CBE-42</b>	4.5	4~42	7~36	7~30	34.3(3500)	78.4(8000)	7000	6	RG-42	TK-B846	2.8(28)
<b>CBE-4212</b>	4.5	4~42	7~36	7~30	34.3(3500)	78.4(8000)	7000	6	RG-42	TK-B846	2.8(28)
<b>CBE-42 A5</b>	4.5	4~42	7~36	7~30	34.3(3500)	78.4(8000)	7000	6.3	RG-42	TK-B846	2.8(28)
<b>CBE-42 A6</b>	4.5	4~42	7~36	7~30	34.3(3500)	78.4(8000)	7000	7.4	RG-42	TK-B846	2.8(28)
<b>CBE-52</b>	4.5	4~52	7~36	7~30	39.2(4000)	92.1(9400)	7000	6.9	RG-52	TK-A853	3.2(32)
<b>CBE-5212</b>	4.5	4~52	7~36	7~30	39.2(4000)	92.1(9400)	7000	6.7	RG-52	TK-A853	3.2(32)
<b>CBE-5217</b>	4.5	4~52	7~36	7~30	39.2(4000)	92.1(9400)	7000	8.9	RG-52	TK-A853	3.2(32)
<b>CBE-52 A5</b>	4.5	4~52	7~36	7~30	39.2(4000)	92.1(9400)	7000	7.8	RG-52	TK-A853	3.2(32)
<b>CBE-52 A6</b>	4.5	4~52	7~36	7~30	39.2(4000)	92.1(9400)	7000	8.3	RG-52	TK-A853	3.2(32)
<b>CBE-65</b>	4.5	4~65	8~56	8~46	44.1(4500)	103(10500)	6000	8.6	RG-65	TS-866	3.0(30)
<b>CBE-6514</b>	4.5	4~65	8~56	8~46	44.1(4500)	103(10500)	6000	9.3	RG-65	TS-866	3.0(30)
<b>CBE-65 A5</b>	4.5	4~65	8~56	8~46	44.1(4500)	103(10500)	6000	10.8	RG-65	TS-866	3.0(30)
<b>CBE-65 A6</b>	4.5	4~65	8~56	8~46	44.1(4500)	103(10500)	6000	9.5	RG-65	TS-866	3.0(30)
<b>CBE-65 A8</b>	4.5	4~65	8~56	8~46	44.1(4500)	103(10500)	6000	9.5	RG-65	TS-866	3.0(30)

## DIMENSIONS

Model	A	A1	A2	B	C (H6)	D	D1	E	E1	F	G max.	G min.	H	J	K max.	L	L1	M
<b>CBE-42</b>	150	132	100	95	140	104.8	-	5	20	48	5.5	1	17	45	M55x2	4~M10x25	19.5	58
<b>CBE-4212</b>	132	132	100	95	120	100	-	5	-	48	5.5	1	17	45	M55x2	4~M10x25	19.5	58
<b>CBE-42 A5</b>	132	132	100	105	-	104.8	82.56	-	-	48	20.5	16	17	45	M55x2	4~M10x30	16	68
<b>CBE-42 A6</b>	160	132	100	105	-	133.4	106.38	-	35	48	20.5	16	17	45	M55x2	4~M12x35	18	68
<b>CBE-52</b>	150	140	107	99	140	104.8	-	5	-	52	5.5	1	17	56	M60x2	4~M10x20	14.5	60
<b>CBE-5212</b>	140	140	107	99	120	100	-	5	-	52	5.5	1	17	56	M60x2	4~M10x20	14.5	60
<b>CBE-5217</b>	180	140	107	109	170	133.4	-	6	-	52	14.5	10	17	56	M60x2	4~M12x30	18	70
<b>CBE-52 A5</b>	140	140	107	109	-	104.8	82.56	-	-	52	20.5	16	17	56	M60x2	4~M10x30	16	70
<b>CBE-52 A6</b>	160	140	107	109	-	133.4	106.37	-	-	52	20.5	16	17	56	M60x2	4~M12x35	18	70
<b>CBE-65</b>	180	157	122	114	170	133.4	-	6	24	56	15	10.5	17.5	68	M75x2	4~M12x30	18	72
<b>CBE-6514</b>	157	157	122	116	140	104.8	-	6	-	56	17	12.5	17.5	68	M75x2	4~M10x30	18	74
<b>CBE-65 A5</b>	157	157	122	114	-	104.8	82.56	-	-	56	21	16.5	17.5	68	M75x2	4~M10x25	16	72
<b>CBE-65 A6</b>	157	157	122	112	-	133.4	106.38	-	-	56	19	14.5	17.5	68	M75x2	4~M12x35	18.5	70
<b>CBE-65 A8</b>	202	157	122	116	-	171.4	139.72	-	38	56	23	18.5	17.5	68	M75x2	4~M16x35	24	74



- The push-forward clamping, combined with a stop block mechanism, features radial clamping with zero radial displacement, enabling precise positioning of the workpiece feeding length for improved length accuracy control.
  - Combined with AUTOGRIP rubber collets, it prevents the typical forward pushing of elastic collets, preserving the integrity of the workpiece surface.
  - The material stopper and dust cover can be interchanged for combined use, balancing through-hole applications and chip prevention functionality, suitable for sub-spindle clamping to reduce clamping pressure effects.
- J is the hole diameter of blank draw nut.  
K is the maximum thread specification and it could be customize.

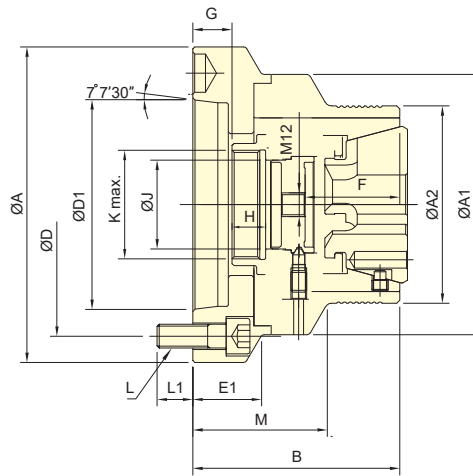
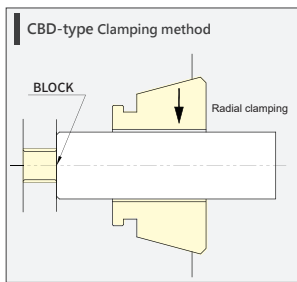

CBD-A

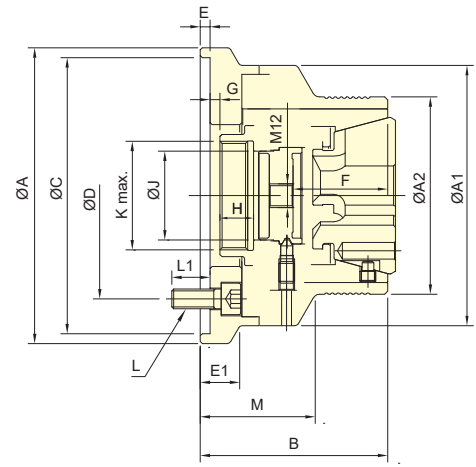

CBD

Subject to technical changes

## SPECIFICATIONS

Model	Plunger stroke mm	Max. Chucking Capacity			Max. D.B. pull kN (kgf)	Max. clamping force kN (kgf)	Max. speed min <sup>-1</sup> (r.p.m.)	Weight kg	Matching steel collet	Matching Cyl.	Max. pressure MPa (kgf/cm <sup>2</sup> )	
		Round mm	Hexagom mm	Square mm								
CBD-52	4.5	4~52	7~36	7~45	39.2(4000)	92.1(9400)	7000	7.3	RG-52	TK-A853	3.0(30)	
CBD-5212	4.5	4~52	7~36	7~45	39.2(4000)	92.1(9400)	7000	7.1	RG-52	TK-A853	3.0(30)	
CBD-5217	4.5	4~52	7~36	7~45	39.2(4000)	92.1(9400)	7000	10.9	RG-52	TK-A853	3.0(30)	
CBD-52	A5	4.5	4~52	7~36	7~45	39.2(4000)	92.1(9400)	7000	7.8	RG-52	TK-A853	3.0(30)
CBD-52	A6	4.5	4~52	7~36	7~45	39.2(4000)	92.1(9400)	7000	9.1	RG-52	TK-A853	3.0(30)
CBD-65		4.5	4~65	8~56	8~46	44.1(4500)	103(10500)	6000	8.6	RG-65	TS-866	2.7(27)
CBD-6514		4.5	4~65	8~56	8~46	44.1(4500)	103(10500)	6000	9.3	RG-65	TS-866	2.7(27)
CBD-65	A5	4.5	4~65	8~56	8~46	44.1(4500)	103(10500)	6000	10.8	RG-65	TS-866	2.7(27)
CBD-65	A6	4.5	4~65	8~56	8~46	44.1(4500)	103(10500)	6000	9.5	RG-65	TS-866	2.7(27)
CBD-65	A8	4.5	4~65	8~56	8~46	44.1(4500)	103(10500)	6000	9.5	RG-65	TS-866	2.7(27)

## DIMENSIONS

Model	A	A1	A2	B	C (H6)	D	D1	E	E1	F	G max.	G min.	H	J	K max.	L	L1	M
CBD-52	150	140	116	99	140	104.8	-	5	-	52	7	2.5	17	56	M60x2	4~M10x20	14.5	57
CBD-5212	140	140	116	99	120	100	-	5	-	52	7	2.5	17	56	M60x2	4~M10x20	14.5	57
CBD-5217	180	140	116	109	170	133.4	-	6	-	52	16	11.5	17	56	M60x2	4~M12x30	18	67
CBD-52	A5	140	140	116	109	-	104.8	82.56	-	52	22	17.5	17	56	M60x2	4~M10x30	16	67
CBD-52	A6	160	140	116	109	-	133.4	106.38	-	52	22	17.5	17	56	M60x2	4~M12x35	18	67
CBD-65		180	157	132	112	170	133.4	-	6	24	54	15.5	11	68	M75x2	4~M12x30	18	70
CBD-6514		157	157	132	114	140	104.8	-	6	-	54	17.5	13	68	M75x2	4~M10x30	18	72
CBD-65	A5	157	157	132	112	-	104.8	82.56	-	54	21.5	17	17.5	68	M75x2	4~M10x25	16	70
CBD-65	A6	157	157	132	110	-	133.4	106.38	-	54	19.5	15	17.5	68	M75x2	4~M12x35	18.5	68
CBD-65	A8	202	157	132	114	-	171.4	139.72	-	38	54	23.5	19	68	M75x2	4~M16x35	24	72



- Simple, concise, and lightweight design.
- Rear pull positioning clamping, with a stopper block mechanism. Equipped with radial clamping and axial fine-tuning torque, it can precisely position the workpiece's material entry length, ensuring more accurate length control.
- The stopper block and dust cover can be interchanged, allowing for through-hole applications and dustproof functionality.
- J is the hole diameter of blank draw nut.
- K is the maximum thread specification and it could be customize.

COLLET CHUCKS

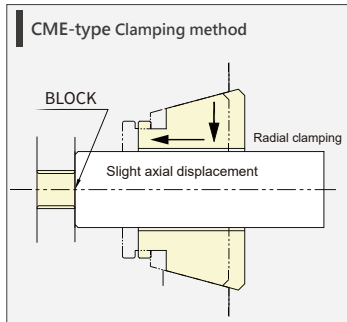

With the material stop mechanism in place, the workpiece does not shift backward during clamping, although there may be slight scuff marks on the surface.

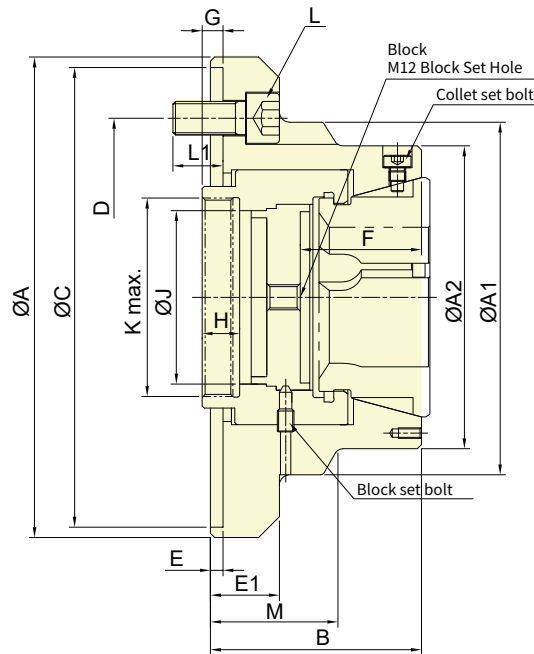

Subject to technical changes

## SPECIFICATIONS

Model	Plunger stroke mm	Max. Chucking Capacity			Max. D.B. pull kN (kgf)	Max. clamping force kN (kgf)	Max. speed min <sup>-1</sup> (r.p.m.)	Weight kg	Matching steel collet	Matching Cyl.	Max. pressure MPa (kgf/cm <sup>2</sup> )
		Round mm	Hexagom mm	Square mm							
<b>CME-80</b>	4.5	5~80	8~68	8~56	50.0(5100)	115(11730)	6500	13.6	RG-80	TK-A1287	2.3(23)

## DIMENSIONS

Model	A	A1	B	C (H6)	D	E	E1	F	G max.	G min.	H	J	K max.	L	L1	M
<b>CME-80</b>	230	170	101	220	171.4	6	33	58	12	7.5	18	83	M95x2	3~M16x35	24	61



- Compact and lightweight design with simplified structure.
  - Dead length clamping with a built-in work stop ensures zero axial movement for precise workpiece positioning.
  - Compatible with AUTOGRIP rubber collets to prevent forward push and protect the workpiece surface.
  - Interchangeable work stop and dust cover for through-hole machining and chip protection. Ideal for sub-spindle clamping with reduced axial clamping force.
- J is the hole diameter of blank draw nut.  
K is the maximum thread specification and it could be customize.

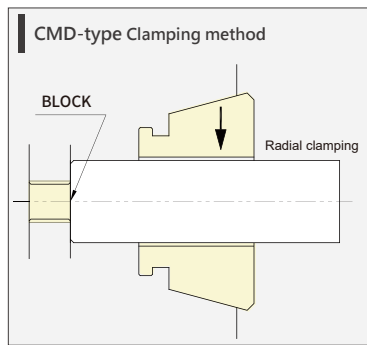

When clamping, the workpiece does not shift forward.

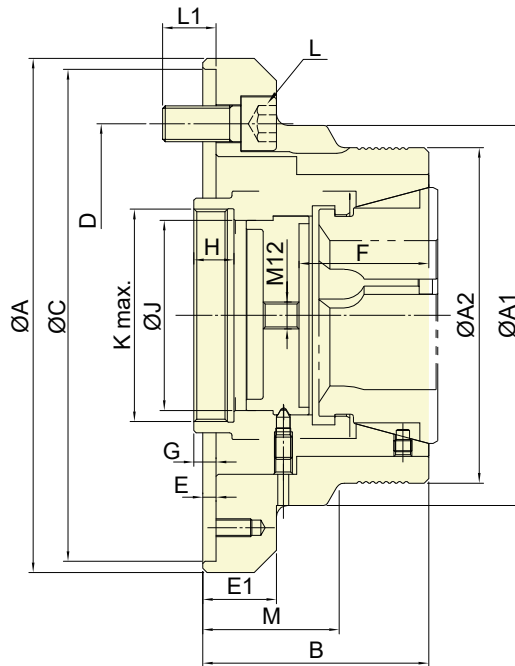

Subject to technical changes

## SPECIFICATIONS

Model	Plunger stroke	Max. Chucking Capacity			Max. D.B. pull	Max. clamping force	Max. speed	Weight	Matching steel collet	Matching Cyl.	Max. pressure
		Round	Hexagom	Square							
		mm	mm	mm							mm
<b>CMD-80</b>	4.5	5~80	8~68	8~56	50.0(5100)	115(11730)	6500	13.6	RG-80	TK-A1287	2.3(23)

## DIMENSIONS

Model	A	A1	A2	B	C (H6)	D	E	E1	F	G max.	G min.	H	J	K max.	L	L1	M
<b>CMD-80</b>	230	170	150	101	220	171.4	6	33	58	12.5	8	18	85	M95x2	3~M16X35	24	61



- Build-in cylinder, ideal for drilling machines, milling machines and machining centers
- Work with AUTOGRIP's rubber collet(RG series), quick change and saving runtime.
- Two modes for the media supply: side-supply mode or baseplate-supply mode.

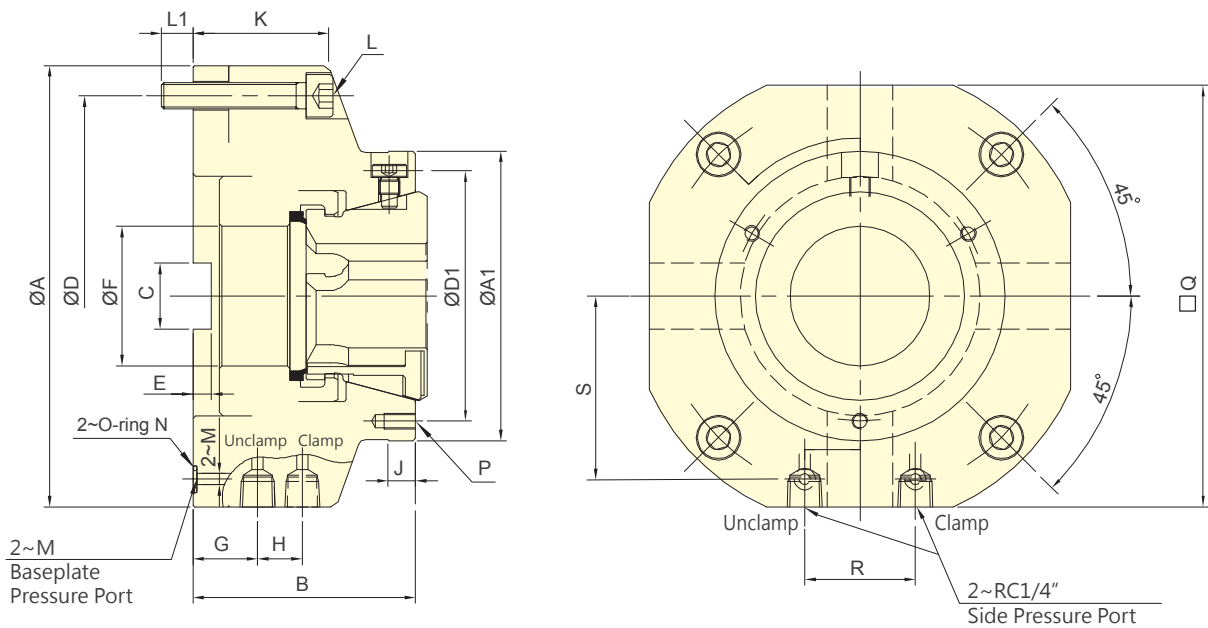

Subject to technical changes

## SPECIFICATIONS

Model	Jaw stroke (Dia.) mm	Max. Chucking Capacity			Max. clamping force Pneumatic kN (kgf)	Max. clamping force Hydraulic kN (kgf)	Max. pressure Pneumatic MPa (kgf/cm <sup>2</sup> )	Max. pressure Hydraulic MPa (kgf/cm <sup>2</sup> )	Weight kg	Matching steel collet
		Round mm	Hexagom mm	Square mm						
<b>SCB-52</b>	± 0.5	4~52	7~45	7~36	8.2(837)	101(10300)	0.6(6)	4.0(40)	8.6	RG-52
<b>SCB-65</b>	± 0.5	4~65	8~56	8~46	10(1020)	105(10700)	0.6(6)	4.2(42)	10.2	RG-65

## DIMENSIONS

Model	A (g6)	A1	B	C	D	D1	E	F	G	H
<b>SCB-52</b>	175	110	84.5	25	152	95	7	53	24.5	17
<b>SCB-65</b>	192	130	94	30	169	114	9	66	26.5	20

Model	J	K	L	L1	M	N	P	Q	R	S
<b>SCB-52</b>	10	51.5	4~M10	12	4.2	P7	3~M6x12	160	42	69.5
<b>SCB-65</b>	10	61.5	4~M10	12.5	4.2	P7	3~M6x12	175	50	77



- Rubber grip collet for push type or draw type collet chucks.
- Full gripping area: high rigidity, more gripping force.  
Gripping smoothly: prevent to damage the workpiece.
- More accurate than standard spring collets.  
Accuracy: With customized rubber grip collet.
- Grip Range:  $\pm 0.5\text{mm}$ .
- Quick change and easy.
- Dust-proof and swarf-proof design.

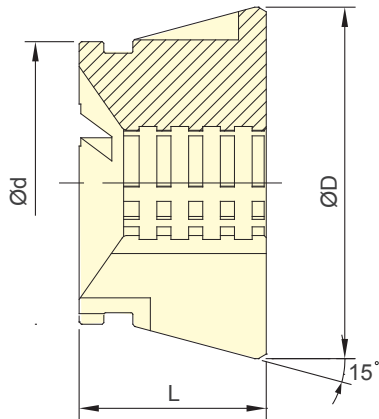

RG-RT

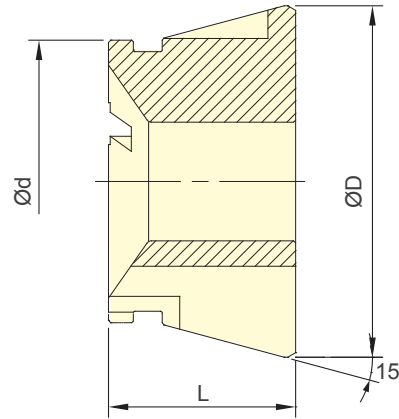

RG-R

Subject to technical changes

## SPECIFICATIONS

Model	Max. Chucking Capacity	d	D	L	Matching Collect Chuck
	Round mm				
RG-42R	4~42	54	79.3	42	CB-42, CBE-42
RG-42RT	11~42	54	79.3	42	CB-42, CBE-42
RG-52R	4~52	66	79.3	46	CB-52, CBD-52, CBE-52, SCB-52
RG-52RT	11~52	66	79.3	46	CB-52, CBD-52, CBE-52, SCB-52
RG-65R	4~65	80	99.5	53	CB-65, CBD-65, CBE-65, SCB-65
RG-65RT	11~65	80	99.5	53	CB-65, CBD-65, CBE-65, SCB-65

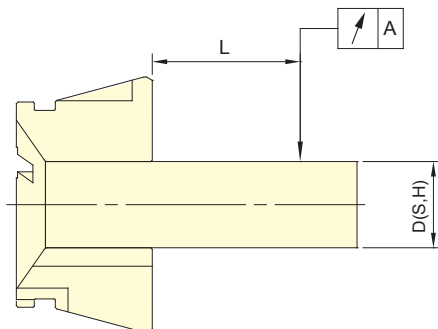

Test Bar D(S,H)	L	A DIN	
	mm	Class1	Class2
3.0~6.0	16	0.015	0.020
6.0~10.0	25	0.015	0.020
10.0~18.0	40	0.020	0.030
18.0~24.0	50	0.020	0.030
24.0~30.0	60	0.020	0.030
30.0~50.0	80	0.030	0.040
50.0~60.0	100	0.030	0.040

Note1 : Collets chuck are conformed to DIN 6343 Class2.

Note2 : AUTOGRIP's rubber grip collets are conformed to DIN 6343 Class1.