

\*訂購時請將圖面連同訂單一併回傳。 \*Please send back with order while ordering.

客戶確認 Confirmed

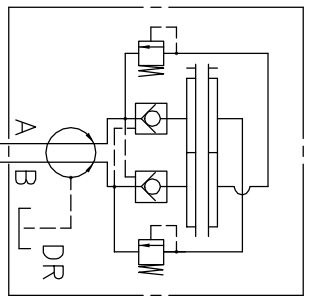
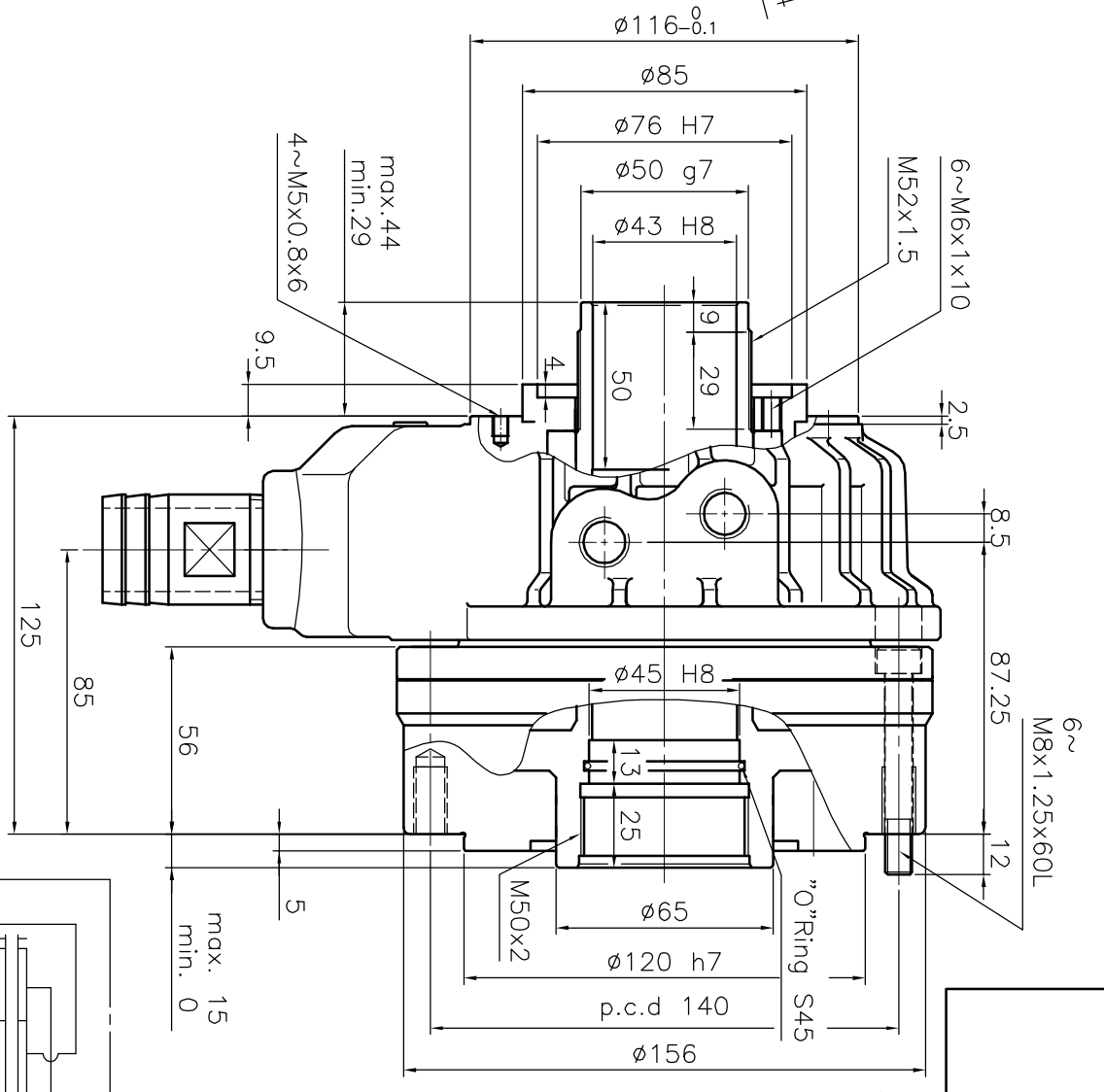
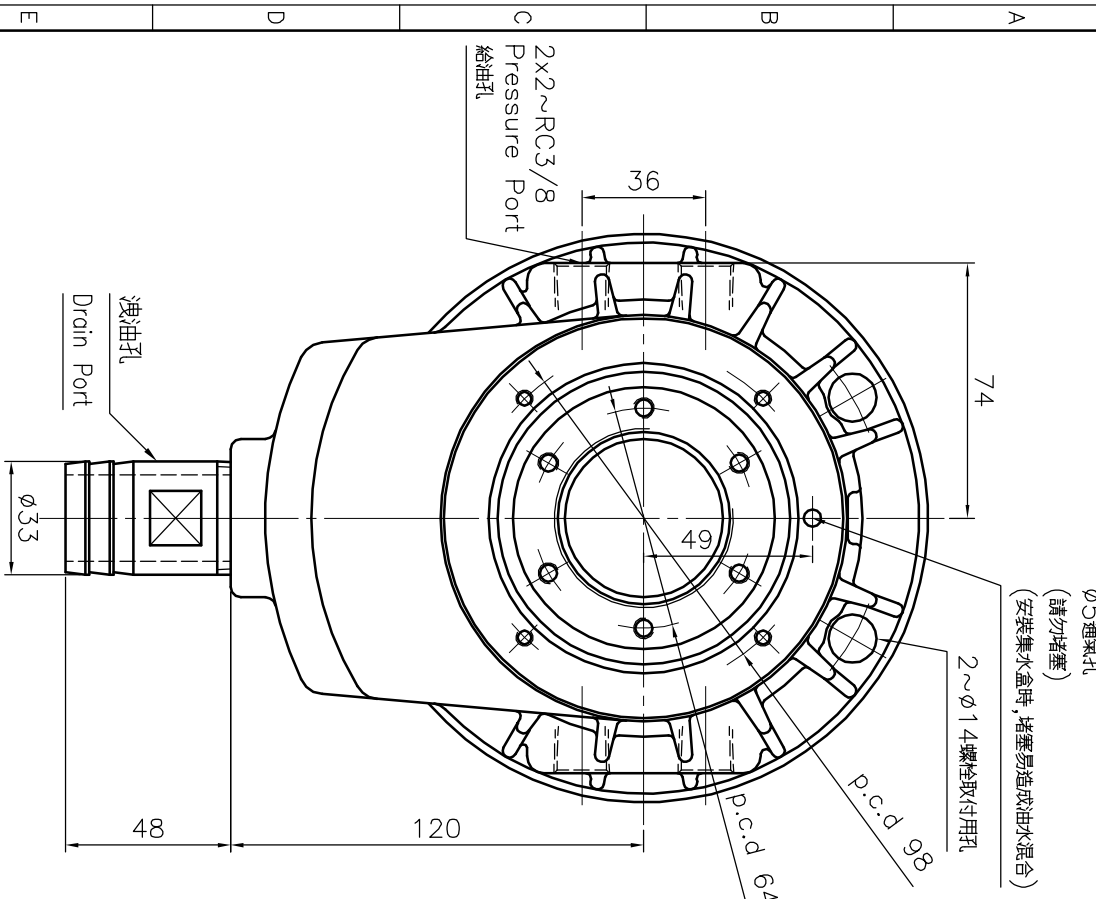

名稱 Name	超短型中空迴轉油壓缸 SHORT TYPE ROTARY HYD. CYLINDER
規格 Spec. 型號 Model	TK-C643
活塞面積 Eff. piston area	伸側 Extend cm <sup>2</sup> 99.1 拉側 Retract cm <sup>2</sup> 88.0
行程 Piston stroke	15
最高使用迴轉數 Max. speed	r.p.m. 7000
最高使用壓力 Max. pressure	kjf/cm <sup>2</sup> 45
GD <sup>2</sup> Moment of inertia	kjf m <sup>2</sup> 0.018
重量 Weight	kgs 7.5
總洩油量 Total leakage	liter/min 3.0

- 洩油孔直管務必單獨接回油槽，以避免產生背壓。
- The drain port should be independently connected to oil tank to avoid back pressure.

\*為確保產品品質日益精進，敝公司擁有設計變更之權。  
\*Subject to technical changes.

佳質  
2022-08-19  
正式發行