

- Super high speed, light weight large Through-Hole.
- Built-in check valve which prevents the internal pressure from sudden declining so that the workpiece will not fly out and cause a serious accident.

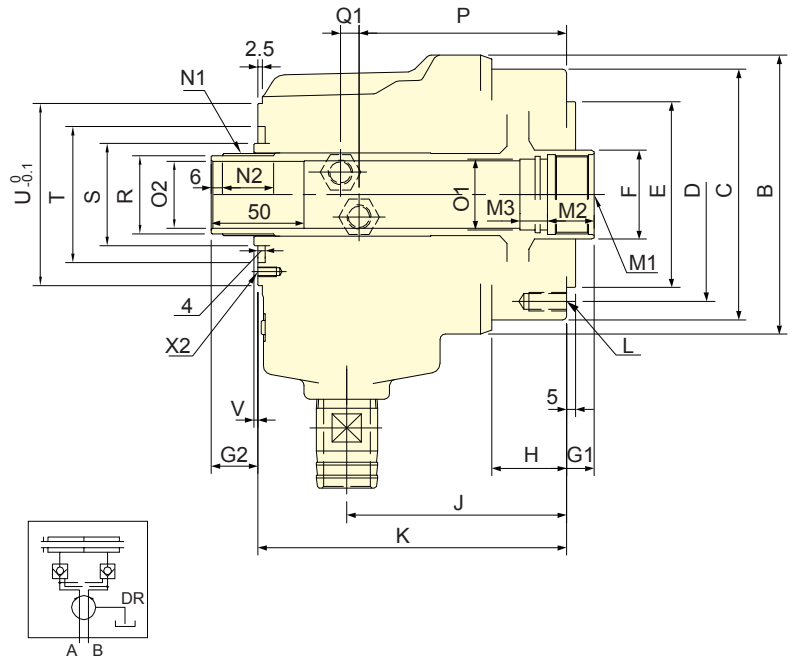
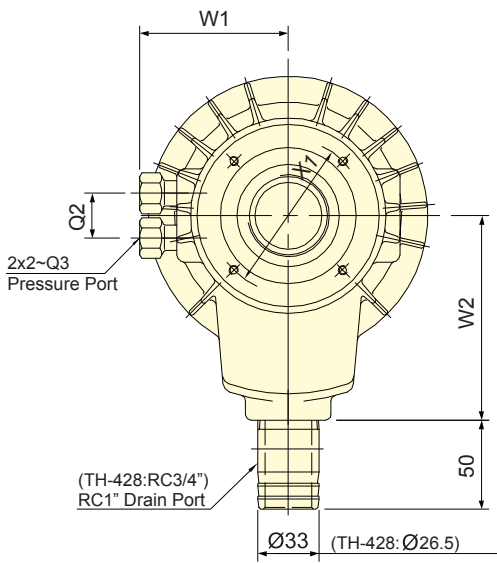

Subject to technical changes
SPECIFICATIONS

Model	Eff. piston area		Piston stroke	Max. speed	Max. pressure	I Moment of inertia	Weight	Total oil leakage
	Extend	Retract						
	cm ²	cm ²						
TH-428	53.2	50.5	10	8000	4.0(40)	0.008	5.8	3.0
TH-A536	69.8	67.5	15	8000	4.0(40)	0.05	8.3	3.0

DIMENSIONS

Model	A I.D.	B	C	D	E (h7)	F	G1 max.	G1 min.	G2 max.	G2 min.	H	J	K	L	M1	M2	M3
TH-428	90	130	120	100	80	40	10	0	35	25	45	127.5	155	6-M8x15	M33x1.5	25	12
TH-A536	105	150	135	115	100	48	15	0	40	25	40	118	166	6-M10x20	M42x1.5	25	15

Model	N1	N2	O1 (H8)	O2 (H8)	P	Q1	Q2	Q3	R (g7)	S	T	U	V	W1	W2	X1	X2
TH-428	M34x1.5	26	30	28	101.5	11	24	RC1/4	32	45	65	86	4	72	105	76	M4x7
TH-A536	M44x1.5	28	38	36	111.5	10	24	RC1/4	42	55	73	98	4	80	110	83	M5x10