

1	2	3	4	5	6	7	8	
規格 Spec. 型號 Model	爪行程 mm Jaw Stroke (Dia.)	夾持直徑 Gripping Dia. mm 最大 Max. 最小 min.	最大夾持力 Max gripping force kN 氣壓 Pneumatic at 0.7 Mpa 油壓 Hydraulic at 1.2 Mpa	最高使用壓力 Max pressure Mpa 氣壓 Pneumatic 油壓 Hydraulic	最低使用壓力 Mpa Min. pressure	空氣消耗量(使用壓力 0.6 Mpa) lit Air consumption (at 0.6 Mpa)	重量 kg Weight	客戶確認 Confirmed
SP-206	5.5	168 30	14 24	7 12	2	1.4	16	

※訂購時請將圖面連同訂單一併回傳。 ※Please send back with order while ordering.

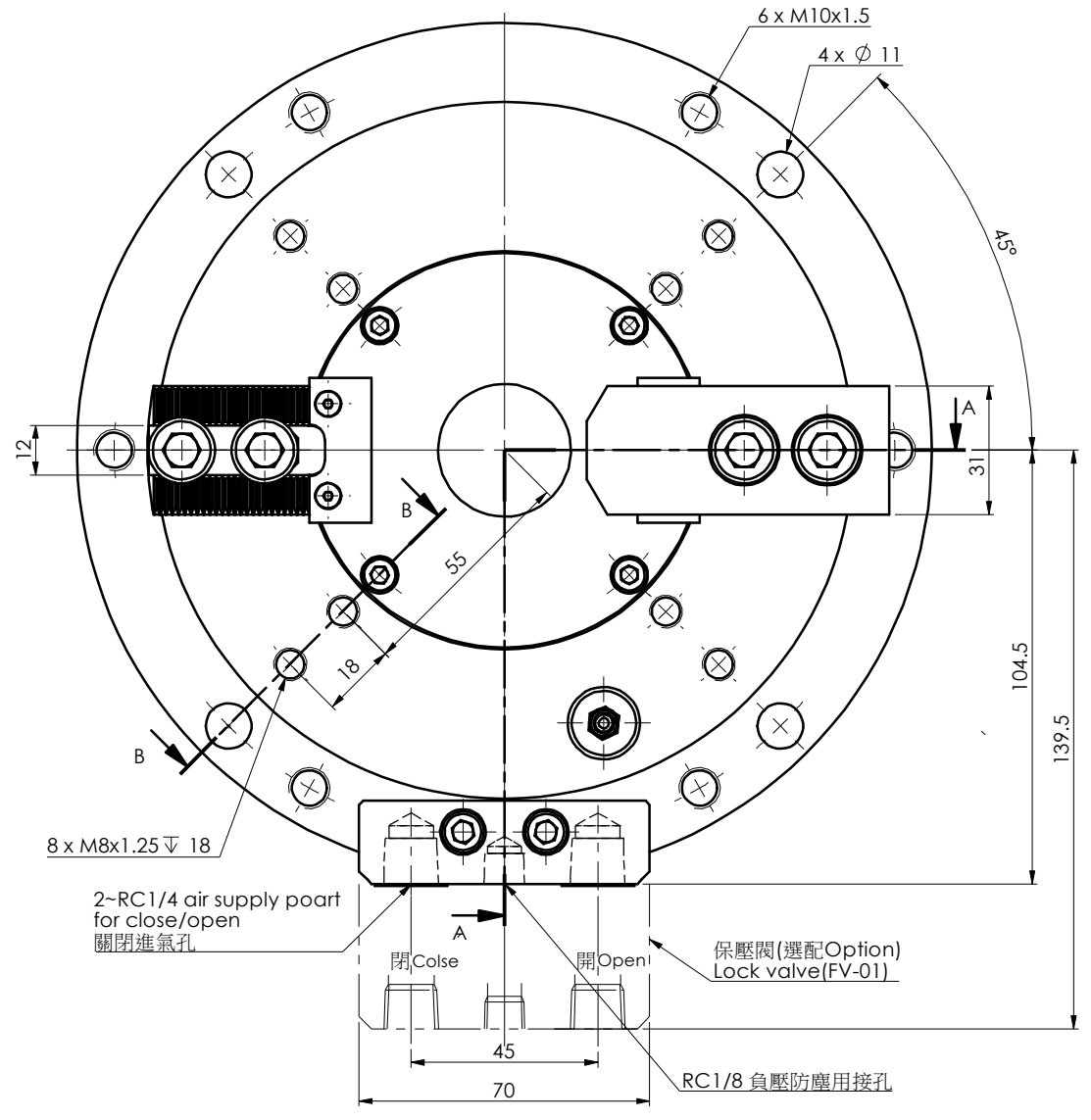
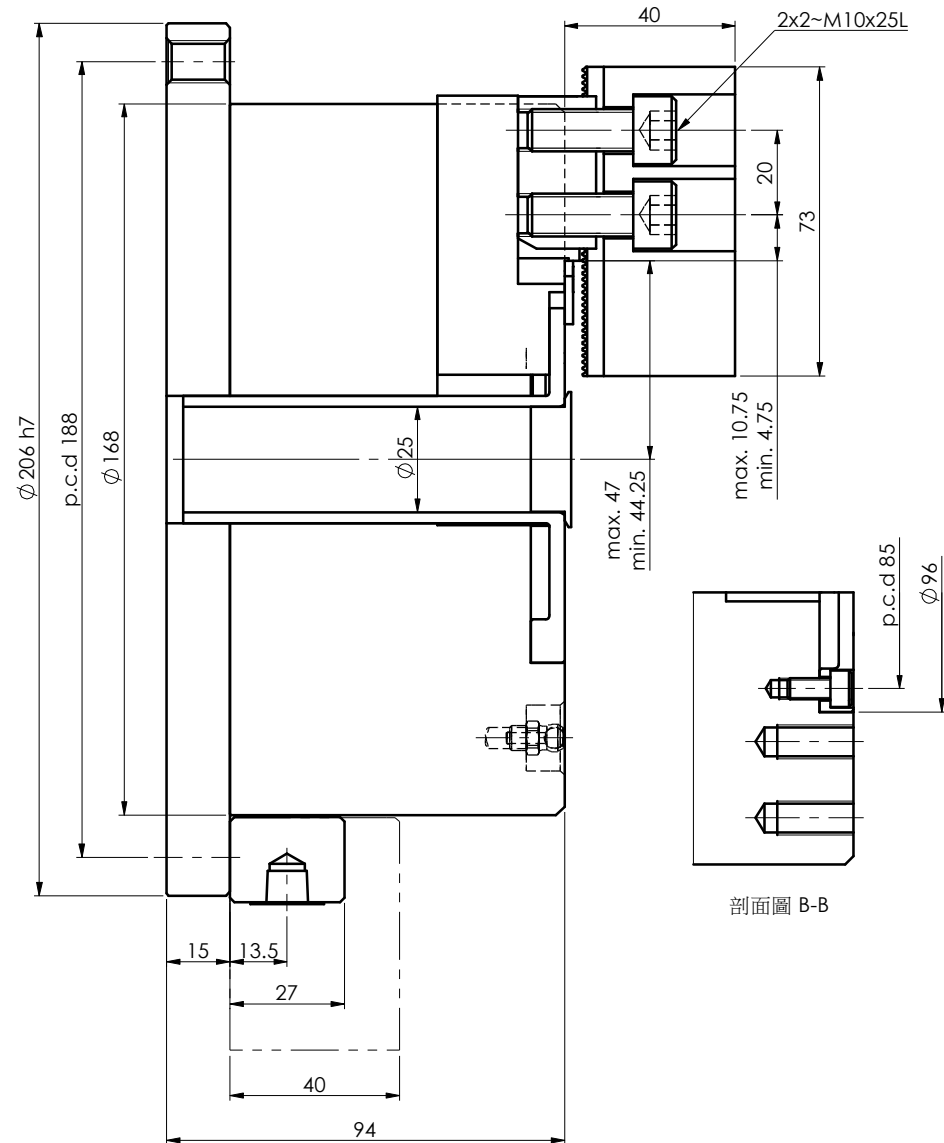

立置式二爪夾頭 剖面圖 A-A

※為確保產品品質日益精進，敝公司擁有設計變更之權。 ※Subject to technical changes.