

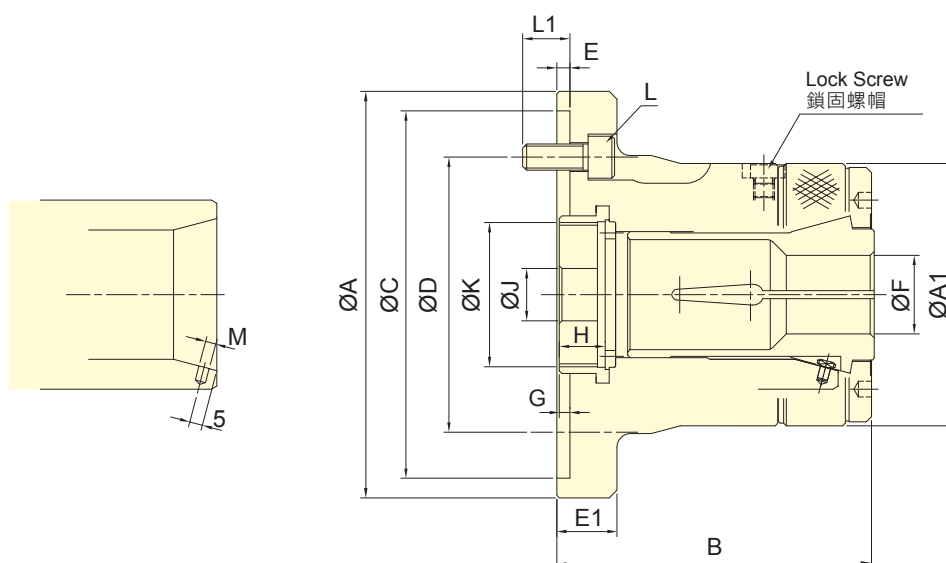

- 前推式彈性筒夾夾頭 · 適合CNC車床 · 專用機 · 或其他旋削機械。
- 高精度 · 高轉速及高剛性結構。
- 全面防水設計 · 防止切削水進入主軸通孔處。
- PUSH type collet used mainly on turning, CNC, special purpose machines , ect.
- High clamping accuracy, high speed and high rigidity.
- Sealed against swarf, chips and coolant.
- 搭配彈性筒夾須符合 DIN 6343 規範。
- The collet used must accord with DIN 6343.
- 專利產品字號 Patent numbers :
台灣 : PAT.NO.M380842(Taiwan)
大陸 : PAT.NO.ZL201020113762.X(China)



保留規格修改的權利
Subject to technical changes

技術規格 SPECIFICATIONS

型號 Model	套筒行程 Plunger stroke mm	最大夾持能力 Max. Chucking Capacity			容許最大入力 Max. D.B. pull kN (kgf)	最大夾持力 Max. clamping force kN (kgf)	最高迴轉數 Max. speed min ⁻¹ (r.p.m.)	I Moment of inertia kg·m ²	重量 Weight kg	使用筒夾 Matching steel collet	適用迴轉缸 Matching Cyl.	最大使用壓力 Max. pressure MPa (kgf/cm ²)
		圓棒 Round mm	六角材 Hexagom mm	方材 Square mm								
CL-26	4.5	3~26	4~22	4~18	17.6(1800)	37.9(3870)	8000	0.040	4.3	161E	TK-A533	2.4(24)
CL-30	4.5	3~30	4~26	4~20	19.6(2000)	42.1(4300)	8000	0.038	4.2	163E	TK-A533	2.7(27)
CL-36	6	3~36	6~32	6~26	22.5(2300)	48.5(4950)	6000	0.062	7.0	171E	TK-C643	2.3(23)
CL-42	6	3~42	6~36	6~29	24.5(2500)	52.9(5400)	6000	0.060	6.9	173E	TK-C643	2.5(25)
CL-52	6	5~52	8~45	7~36	27.4(2800)	59.0(6020)	6000	0.101	14.3	177E	TK-A853	2.0(20)
CL-6017	6	5~60	8~52	7~42	29.4(3000)	63.7(6500)	5000	0.098	14.1	185E	TS-866	1.8(18)
CL-6022	6	5~60	8~52	7~42	29.4(3000)	63.7(6500)	5000	0.126	16.3	185E	TS-866	1.8(18)
CL-80	6	20~80	18~69	15~56	34.3(3500)	71.5(7300)	4000	0.108	17.8	193E	TK-A1287	1.6(16)

外型尺寸 DIMENSIONS

Model	A	A1	B	C(H6)	D	E	E1	F max.	F min.	G max.	G min.	H	J	K max.	L	L1	M
CL-26	120	85	100	110	82.6	4	23	26	3	7	2.5	15	12	M40x1.5	3~M10x25	16	4
CL-30	120	85	100	110	82.6	4	23	30	3	7	2.5	15	12	M40x1.5	3~M10x25	16	4
CL-36	155	100	120	140	104.8	5	23	36	3	7	1	17.5	20	M55x2	3~M10x25	18	4
CL-42	155	100	120	140	104.8	5	23	42	3	7	1	17.5	20	M55x2	3~M10x25	18	4
CL-52	185	130	145.5	170	133.4	5	27	52	5	9	3	24	30	M60x2	6~M12x30	20	5
CL-6017	185	130	145.5	170	133.4	5	27	60	5	9	3	24	45	M75x2	6~M12x30	20	5
CL-6022	234	130	142	220	171.4	5	32	60	5	13	7	24	45	M85x2	6~M16x30	20	5
CL-80	234	156	163	220	171.4	5	32	80	20	15.5	9.5	22	45	M100x2	6~M16x30	20	5



- 前推式彈性筒夾夾頭，適合CNC車床，專用機，或其他旋削機械。
- 高精度，高轉速及高剛性結構。
- 全面防水設計，防止切削水進入主軸通孔處。
- PUSH type collet used mainly on turning, CNC, special purpose machines, ect.
- High clamping accuracy, high speed and high rigidity.
- Sealed against swarf, chips and coolant.
- 搭配彈性筒夾須符合 DIN 6343 規範。
- The collet used must accord with DIN 6343.
- 專利產品字號 Patent numbers :
台灣：PAT.NO.M380842(Taiwan)
大陸：PAT.NO.ZL201020113762.X(China)

筒夾夾頭

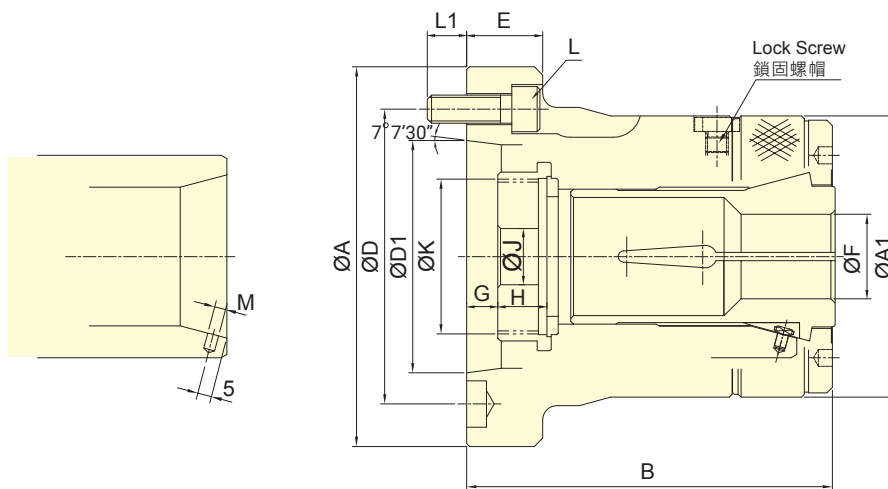
 保留規格修改的權利
Subject to technical changes

技術規格 SPECIFICATIONS

型號 Model	套筒行程 Plunger stroke mm	最大夾持能力 Max. Chucking Capacity			容許最大 入力 Max. D.B. pull kN (kgf)	最大夾持力 Max. clamping force kN (kgf)	最高迴轉數 Max. speed min ⁻¹ (r.p.m.)	I Moment of inertia kg·m ²	重量 Weight kg	使用筒夾 Matching steel collet	適用迴轉缸 Matching Cyl.	最大使用 壓力 Max. pressure MPa (kgf/cm ²)	
		圓棒 Round mm	六角材 Hexagom mm	方材 Square mm									
CL-26	A4	4.5	3~26	4~22	4~18	17.6(1800)	37.9(3870)	8000	0.040	4.2	161E	TK-A533	2.4(24)
CL-30	A4	4.5	3~30	4~26	4~20	19.6(2000)	42.1(4300)	8000	0.038	4.1	163E	TK-A533	2.7(27)
CL-36	A5	6	3~36	6~32	6~26	22.5(2300)	48.5(4950)	6000	0.058	6.3	171E	TK-C643	2.3(23)
CL-42	A5	6	3~42	6~36	6~29	24.5(2500)	52.9(5400)	6000	0.057	6.1	173E	TK-C643	2.5(25)
CL-42	A6	6	3~42	6~36	6~29	24.5(2500)	52.9(5400)	6000	0.061	7.5	173E	TK-C643	2.5(25)
CL-52	A6	6	5~52	8~45	7~36	27.4(2800)	59.0(6020)	6000	0.093	13.8	177E	TK-A853	2.0(20)
CL-60	A6	6	5~60	8~52	7~42	29.4(3000)	63.7(6500)	5000	0.091	13.5	185E	TS-866	1.8(18)
CL-60	A8	6	5~60	8~52	7~42	29.4(3000)	63.7(6500)	5000	0.104	14.5	185E	TS-866	1.8(18)
CL-80	A8	6	20~80	18~69	15~56	34.3(3500)	71.5(7300)	4000	0.120	19.8	193E	TK-A1287	1.6(16)

外型尺寸 DIMENSIONS

Model	A	A1	B	D	D1	E	F max.	F min.	G max.	G min.	H	J	K max.	L	L1	M	
CL-26	A4	110	85	108	82.6	63.51	25	26	3	9.5	5	15	12	M40x1.5	3~M10x30	15	4
CL-30	A4	110	85	108	82.6	63.51	25	30	3	9.5	5	15	12	M40x1.5	3~M10x30	15	4
CL-36	A5	135	100	130	104.8	82.56	27	36	3	14	8	17.5	20	M55x2	4~M10x30	14	4
CL-42	A5	135	100	130	104.8	82.56	27	42	3	14	8	17.5	20	M55x2	4~M10x30	14	4
CL-42	A6	165	100	130	133.4	106.38	32	42	3	17	11	17.5	20	M60x2	4~M12x35	16	4
CL-52	A6	170	130	154	133.4	106.38	27	52	5	10.5	4.5	24	45	M60x2	4~M12x35	20	5
CL-60	A6	170	130	154	133.4	106.38	27	60	5	10.5	4.5	24	45	M75x2	4~M12x35	20	5
CL-60	A8	210	130	147.5	171.4	139.72	35	60	5	3.5	-2.5	24	45	M85x2	4~M16x40	22	5
CL-80	A8	210	156	175	171.4	139.72	35	80	20	7.5	1.5	22	45	M100x2	6~M16x40	22	5



- 適合CNC車床·專用機·或其他旋削機械·作棒材或心軸加工用。
- 具軸向與徑向夾持力矩·適合粗重加工。
- 高精度·高轉速及高剛性結構。
- 全面防水設計·防止切削水進入主軸通孔處。
- DRAW BACK type collet chuck used mainly on CNC turning machines, special purpose machines, etc. Suitable for machining bar material and mandrel.
- High clamping accuracy, high speed and high rigidity.
- This is a completely sealed design, which prevents coolant and chips from entering the spindle.
- J 值為連結螺帽未車製螺牙時的孔徑。
K max 值為連結螺帽可車製螺牙之最大規格·可依實際需求訂製。
- J is the hole diameter of blank draw nut.
K is the maximum thread specification and it could be customize.

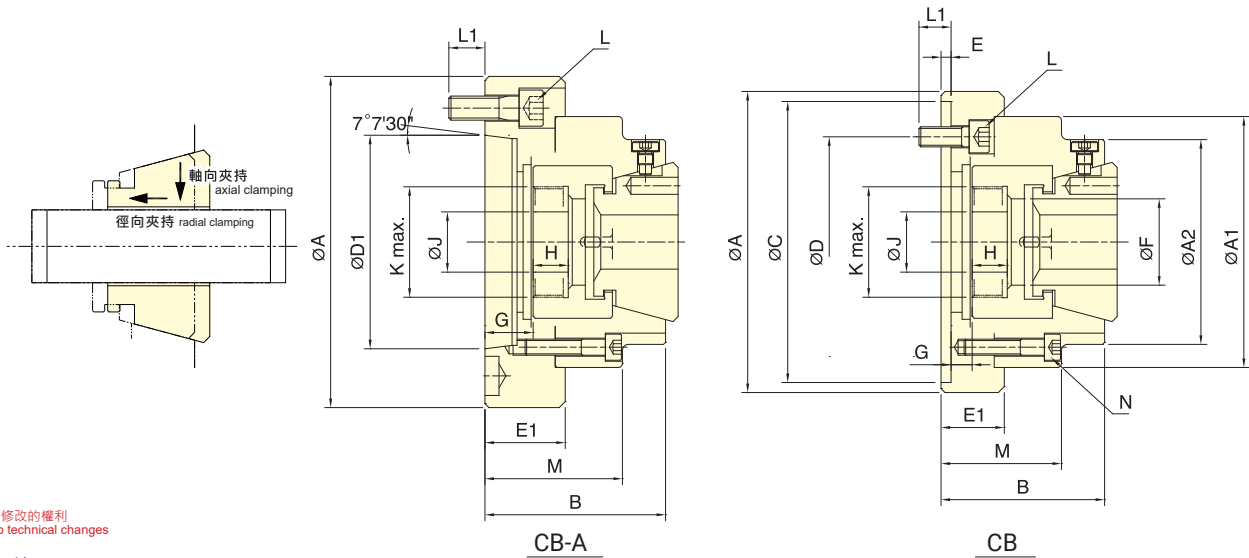

保留規格修改的權利
Subject to technical changes

技術規格 SPECIFICATIONS

型號 Model	套筒行程 Plunger stroke mm	最大夾持能力 Max. Chucking Capacity			容許最大入力 Max. D.B. pull kN (kgf)	最大夾持力 Max. clamping force kN (kgf)	最高迴轉數 Max. speed min ⁻¹ (r.p.m.)	重量 Weight kg	使用筒夾 Matching steel collet	適用迴轉缸 Matching Cyl.	最大使用壓力 Max. pressure MPa (kgf/cm ²)
		圓棒 Round mm	六角材 Hexagom mm	方材 Square mm							
CB-42	4.5	4~42	7~36	7~30	34.3(3500)	78.4(8000)	7000	6.5	RG-42	TK-B846	2.8(28)
CB-42 A5	4.5	4~42	7~36	7~30	34.3(3500)	78.4(8000)	7000	6.2	RG-42	TK-B846	2.8(28)
CB-42 A6	4.5	4~42	7~36	7~30	34.3(3500)	78.4(8000)	7000	7.4	RG-42	TK-B846	2.8(28)
CB-52	4.5	4~52	7~36	7~45	39.2(4000)	92.1(9400)	7000	6	RG-52	TK-A853	3.2(32)
CB-5217	4.5	4~52	7~36	7~45	39.2(4000)	92.1(9400)	7000	9.6	RG-52	TK-A853	3.2(32)
CB-52 A5	4.5	4~52	7~36	7~45	39.2(4000)	92.1(9400)	7000	6.5	RG-52	TK-A853	3.2(32)
CB-52 A6	4.5	4~52	7~36	7~45	39.2(4000)	92.1(9400)	7000	7.8	RG-52	TK-A853	3.2(32)
CB-65	4.5	4~65	8~56	8~46	44.1(4500)	103(10500)	5500	15	RG-65	TS-866	3.0(30)
CB-65 A6	4.5	4~65	8~56	8~46	44.1(4500)	103(10500)	5500	13.6	RG-65	TS-866	3.0(30)
CB-65 A8	4.5	4~65	8~56	8~46	44.1(4500)	103(10500)	5500	17.6	RG-65	TS-866	3.0(30)
CB-80	4.5	5~80	8~68	8~56	50.0(5100)	115(11730)	5500	19	RG-80	TK-A1287	2.3(23)
CB-80 A8	4.5	5~80	8~68	8~56	50.0(5100)	115(11730)	5500	19	RG-80	TK-A1287	2.3(23)

外型尺寸 DIMENSIONS

Model	A	A1	A2	B	C(H6)	D	D1	E	E1	F	G max.	G min.	H	J	K max.	L	L1	M	N
CB-42	150	125	102	81.5	140	104.8	-	5	31	43	10.5	6	17.5	30	M55x2	3~M10x25	11	60	4~M8
CB-42 A5	140	125	102	91.5	-	104.8	82.56	-	41.5	43	25.5	21	17.5	30	M55x2	4~M10x25	12	70	4~M8
CB-42 A6	165	125	102	91.5	-	133.4	106.38	-	45	43	29	24.5	17.5	30	M55x2	4~M12x35	18	73.5	4~M8
CB-52	150	125	102	83.5	140	104.8	-	5	31.5	53	11	6.5	17.5	30	M60x2	4~M10x25	16	62.5	4~M8
CB-5217	180	125	102	87	170	133.4	-	5	35	53	14.5	10	17.5	30	M60x2	4~M12x30	18	66	4~M8
CB-52 A5	140	125	102	93.5	-	104.8	82.56	-	41.5	53	26	21.5	17.5	30	M60x2	4~M10x30	16	72.5	4~M8
CB-52 A6	165	125	102	99	-	133.4	106.38	-	47	53	31.5	27	17.5	30	M60x2	6~M12x35	18	78	4~M8
CB-65	185	145	120	100	170	133.4	-	6	50	66	13.5	9	21.5	32	M75x2	6~M12x40	20	73.5	4~M8
CB-65 A6	165	145	120	111	-	133.4	106.38	-	61	66	30.5	26	21.5	32	M75x2	4~M12x40	20	84.5	4~M8
CB-65 A8	207	145	120	107	-	171.4	139.72	-	57	66	26.5	22	21.5	32	M75x2	4~M16x40	24	80.5	4~M8
CB-80	235	175	150	112	220	171.4	-	5	37	82.5	13.5	8	25	45	M85x2	6~M16x30	22	87	6~M10
CB-80 A8	210	175	150	125	-	171.4	139.72	-	50	82.5	26.5	21	25	45	M85x2	6~M16x50	24	100	6~M10



- 後拉夾持，配合擋料塊機構，可精準定位工件入料長度，使長度精度控制更加精準。
- 具軸向與徑向夾持力矩，適合粗重加工，大型直徑或短型工件。
- 擋料塊與防塵蓋可互換搭配使用，應用與防屑功能可以兼顧。
- End stop clamping.
- With backgauge block mechanism, positioning and the length control of the workpiece can be more precise.
- Backgauge block and cover are interchangeable. The chip-proof function can also be achieved.
- J 值為連結螺帽未車製螺牙時的孔徑。
K max 值為連結螺帽可車製螺牙之最大規格，可依實際需求訂製。
- J is the hole diameter of blank draw nut.
K is the maximum thread specification and it could be customize.

筒夾夾頭

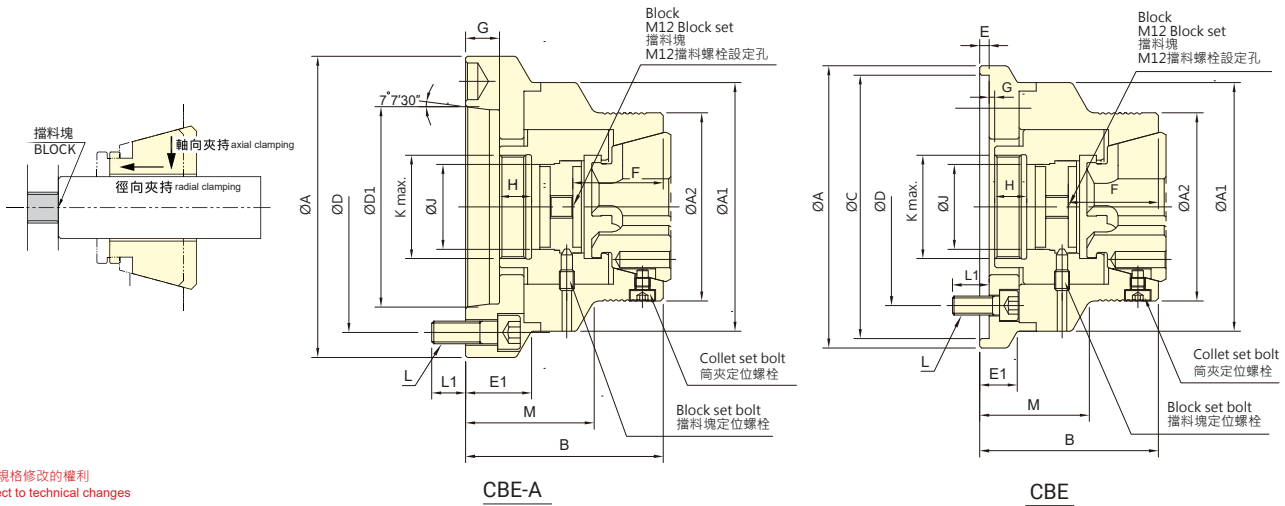

保留規格修改的權利
Subject to technical changes

技術規格 SPECIFICATIONS

型號 Model	套筒行程 Plunger stroke mm	最大夾持能力 Max. Chucking Capacity			容許最大入力 Max. D.B. pull kN (kgf)	最大夾持力 Max. clamping force kN (kgf)	最高迴轉數 Max. speed min ⁻¹ (r.p.m.)	重量 Weight kg	使用筒夾 Matching steel collet	適用迴轉缸 Matching Cyl.	最大使用壓力 Max. pressure MPa (kgf/cm ²)
		圓棒 Round mm	六角材 Hexagom mm	方材 Square mm							
CBE-42	4.5	4~42	7~36	7~30	34.3(3500)	78.4(8000)	7000	6	RG-42	TK-B846	2.8(28)
CBE-4212	4.5	4~42	7~36	7~30	34.3(3500)	78.4(8000)	7000	6	RG-42	TK-B846	2.8(28)
CBE-42 A5	4.5	4~42	7~36	7~30	34.3(3500)	78.4(8000)	7000	6.3	RG-42	TK-B846	2.8(28)
CBE-42 A6	4.5	4~42	7~36	7~30	34.3(3500)	78.4(8000)	7000	7.4	RG-42	TK-B846	2.8(28)
CBE-52	4.5	4~52	7~36	7~30	39.2(4000)	92.1(9400)	7000	6.9	RG-52	TK-A853	3.2(32)
CBE-5212	4.5	4~52	7~36	7~30	39.2(4000)	92.1(9400)	7000	6.7	RG-52	TK-A853	3.2(32)
CBE-5217	4.5	4~52	7~36	7~30	39.2(4000)	92.1(9400)	7000	8.9	RG-52	TK-A853	3.2(32)
CBE-52 A5	4.5	4~52	7~36	7~30	39.2(4000)	92.1(9400)	7000	7.8	RG-52	TK-A853	3.2(32)
CBE-52 A6	4.5	4~52	7~36	7~30	39.2(4000)	92.1(9400)	7000	8.3	RG-52	TK-A853	3.2(32)
CBE-65	4.5	4~65	8~56	8~46	44.1(4500)	103(10500)	6000	8.6	RG-65	TS-866	3.0(30)
CBE-6514	4.5	4~65	8~56	8~46	44.1(4500)	103(10500)	6000	9.3	RG-65	TS-866	3.0(30)
CBE-65 A5	4.5	4~65	8~56	8~46	44.1(4500)	103(10500)	6000	10.8	RG-65	TS-866	3.0(30)
CBE-65 A6	4.5	4~65	8~56	8~46	44.1(4500)	103(10500)	6000	9.5	RG-65	TS-866	3.0(30)
CBE-65 A8	4.5	4~65	8~56	8~46	44.1(4500)	103(10500)	6000	9.5	RG-65	TS-866	3.0(30)

外型尺寸 DIMENSIONS

Model	A	A1	A2	B	C (H6)	D	D1	E	E1	F	G max.	G min.	H	J	K max.	L	L1	M
CBE-42	150	132	100	95	140	104.8	-	5	20	48	5.5	1	17	45	M55x2	4~M10x25	19.5	58
CBE-4212	132	132	100	95	120	100	-	5	-	48	5.5	1	17	45	M55x2	4~M10x25	19.5	58
CBE-42 A5	132	132	100	105	-	104.8	82.56	-	-	48	20.5	16	17	45	M55x2	4~M10x30	16	68
CBE-42 A6	160	132	100	105	-	133.4	106.38	-	35	48	20.5	16	17	45	M55x2	4~M12x35	18	68
CBE-52	150	140	107	99	140	104.8	-	5	-	52	5.5	1	17	56	M60x2	4~M10x20	14.5	60
CBE-5212	140	140	107	99	120	100	-	5	-	52	5.5	1	17	56	M60x2	4~M10x20	14.5	60
CBE-5217	180	140	107	109	170	133.4	-	6	-	52	14.5	10	17	56	M60x2	4~M12x30	18	70
CBE-52 A5	140	140	107	109	-	104.8	82.56	-	-	52	20.5	16	17	56	M60x2	4~M10x30	16	70
CBE-52 A6	160	140	107	109	-	133.4	106.37	-	-	52	20.5	16	17	56	M60x2	4~M12x35	18	70
CBE-65	180	157	122	114	170	133.4	-	6	24	56	15	10.5	17.5	68	M75x2	4~M12x30	18	72
CBE-6514	157	157	122	116	140	104.8	-	6	-	56	17	12.5	17.5	68	M75x2	4~M10x30	18	74
CBE-65 A5	157	157	122	114	-	104.8	82.56	-	-	56	21	16.5	17.5	68	M75x2	4~M10x25	16	72
CBE-65 A6	157	157	122	112	-	133.4	106.38	-	-	56	19	14.5	17.5	68	M75x2	4~M12x35	18.5	70
CBE-65 A8	202	157	122	116	-	171.4	139.72	-	38	56	23	18.5	17.5	68	M75x2	4~M16x35	24	74



- 前推夾持，搭配擋料塊機構，只具軸向夾持軸向零移位，可精準定位工件入料長度，使長度精度控制更加精準。
- 搭配AUTOGRIP橡膠筒夾，不會產生一般彈性筒夾將工件往前推的情況，可使工件表面不受損。
- 擋料塊與防塵蓋可互換搭配使用，通孔應用與防屑功能可以兼顧，適合副主軸夾持，可減少夾持的拉壓力現象。
- Clamping push with the backgauge block mechanism, collet will not be pushed, can precise positioning for workpiece length, make the precision of the length control more precise.
- Match AUTOGRIP's Rubber collet(RG series), clamping direction perpendicular to axis, never occur that situation of collet push workpiece.
- Backgauge block and cover able to interchangeable use, as well as application and chip-proof function.
- J 值為連結螺帽未車製螺牙時的孔徑。
K max 值為連結螺帽可車製螺牙之最大規格，可依實際需求訂製。
- J is the hole diameter of blank draw nut.
K is the maximum thread specification and it could be customize.

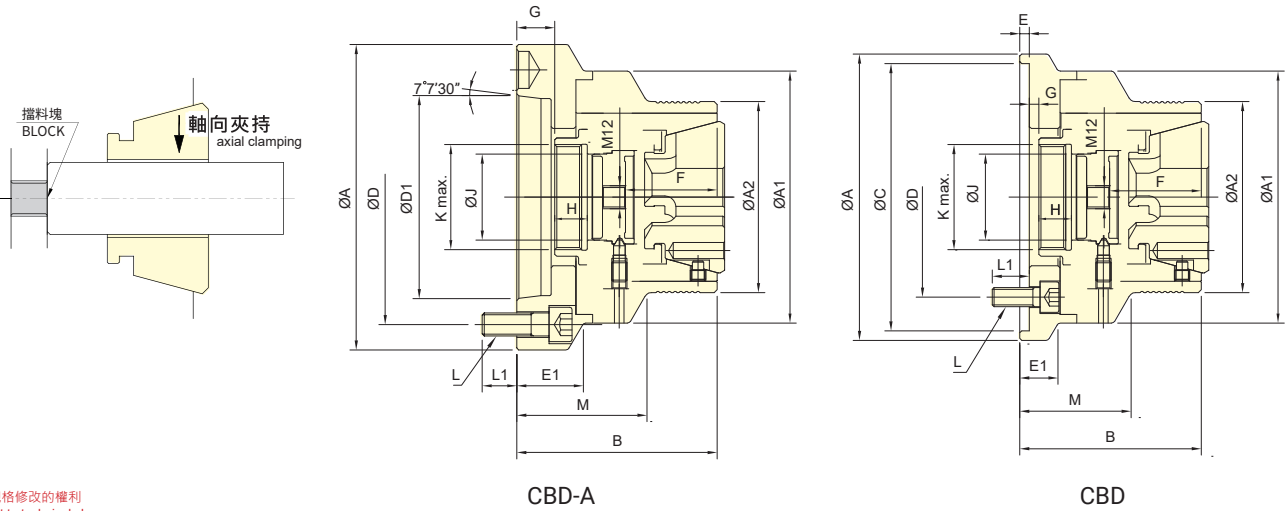

保留規格修改的權利
Subject to technical changes

技術規格 SPECIFICATIONS

型號 Model	套筒行程 Plunger stroke mm	最大夾持能力 Max. Chucking Capacity			容許最大入力 Max. D.B. pull kN (kgf)	最大夾持力 Max. clamping force kN (kgf)	最高迴轉數 Max. speed min ⁻¹ (r.p.m.)	重量 Weight kg	使用筒夾 Matching steel collet	適用迴轉缸 Matching Cyl.	最大使用壓力 Max. pressure MPa (kgf/cm ²)
		圓棒 Round mm	六角材 Hexagom mm	方材 Square mm							
CBD-52	4.5	4~52	7~36	7~45	39.2(4000)	92.1(9400)	7000	7.3	RG-52	TK-A853	3.0(30)
CBD-5212	4.5	4~52	7~36	7~45	39.2(4000)	92.1(9400)	7000	7.1	RG-52	TK-A853	3.0(30)
CBD-5217	4.5	4~52	7~36	7~45	39.2(4000)	92.1(9400)	7000	10.9	RG-52	TK-A853	3.0(30)
CBD-52 A5	4.5	4~52	7~36	7~45	39.2(4000)	92.1(9400)	7000	7.8	RG-52	TK-A853	3.0(30)
CBD-52 A6	4.5	4~52	7~36	7~45	39.2(4000)	92.1(9400)	7000	9.1	RG-52	TK-A853	3.0(30)
CBD-65	4.5	4~65	8~56	8~46	44.1(4500)	103(10500)	6000	8.6	RG-65	TS-866	2.7(27)
CBD-6514	4.5	4~65	8~56	8~46	44.1(4500)	103(10500)	6000	9.3	RG-65	TS-866	2.7(27)
CBD-65 A5	4.5	4~65	8~56	8~46	44.1(4500)	103(10500)	6000	10.8	RG-65	TS-866	2.7(27)
CBD-65 A6	4.5	4~65	8~56	8~46	44.1(4500)	103(10500)	6000	9.5	RG-65	TS-866	2.7(27)
CBD-65 A8	4.5	4~65	8~56	8~46	44.1(4500)	103(10500)	6000	9.5	RG-65	TS-866	2.7(27)

外型尺寸 DIMENSIONS

Model	A	A1	A2	B	C (H6)	D	D1	E	E1	F	G max.	G min.	H	J	K max.	L	L1	M
CBD-52	150	140	116	99	140	104.8	-	5	-	52	7	2.5	17	56	M60x2	4~M10x20	14.5	57
CBD-5212	140	140	116	99	120	100	-	5	-	52	7	2.5	17	56	M60x2	4~M10x20	14.5	57
CBD-5217	180	140	116	109	170	133.4	-	6	-	52	16	11.5	17	56	M60x2	4~M12x30	18	67
CBD-52 A5	140	140	116	109	-	104.8	82.56	-	-	52	22	17.5	17	56	M60x2	4~M10x30	16	67
CBD-52 A6	160	140	116	109	-	133.4	106.38	-	-	52	22	17.5	17	56	M60x2	4~M12x35	18	67
CBD-65	180	157	132	112	170	133.4	-	6	24	54	15.5	11	17.5	68	M75x2	4~M12x30	18	70
CBD-6514	157	157	132	114	140	104.8	-	6	-	54	17.5	13	17.5	68	M75x2	4~M10x30	18	72
CBD-65 A5	157	157	132	112	-	104.8	82.56	-	-	54	21.5	17	17.5	68	M75x2	4~M10x25	16	70
CBD-65 A6	157	157	132	110	-	133.4	106.38	-	-	54	19.5	15	17.5	68	M75x2	4~M12x35	18.5	68
CBD-65 A8	202	157	132	114	-	171.4	139.72	-	38	54	23.5	19	17.5	68	M75x2	4~M16x35	24	72



- 適合鑽床、銑床或切削中心機使用。
- 高精度及高剛性結構。
- 不需要另外搭配立式油壓缸。
- 安裝容易，接上配管即可進行加工。
- 搭配RG系統橡膠筒夾，換模簡便快速。
- 提供側邊配管與底部油路板兩種供油模式。
- Build-in cylinder, ideal for drilling machines, milling machines and machining centers
- Work with AUTOGRIP's rubber collet(RG series), quick change and saving runtime.
- Two modes for the media supply: side-supply mode or baseplate-supply mode.

筒夾夾頭

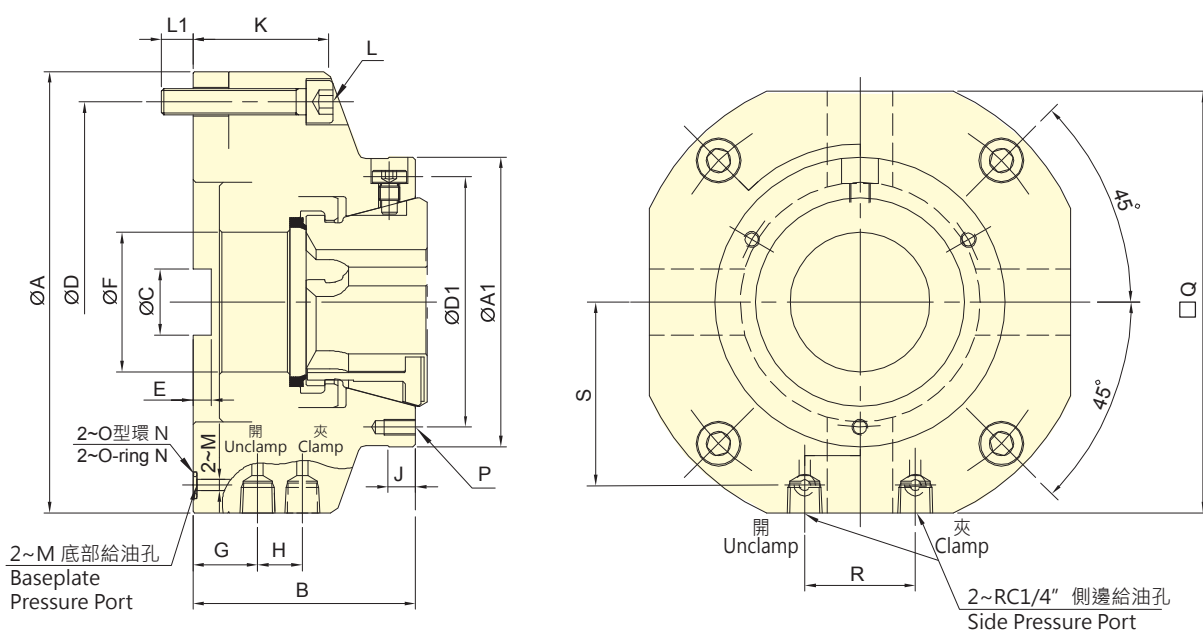

保留規格修改的權利
Subject to technical changes

技術規格 SPECIFICATIONS

型號 Model	爪行程(直徑) Jaw stroke(Dia.)	最大夾持能力 Max. Chucking Capacity			最大夾持力 Max. clamping force	重量 Weight	使用筒夾 Matching steel collet	最大使用壓力 Max. pressure
		圓棒 Round	六角材 Hexagom	方材 Square				
SCB-52	± 0.5	4~52	7~45	7~36	80(8150)	8.6	RG-52	4.0(40)
SCB-65	± 0.5	4~65	8~56	8~46	105(10700)	10.2	RG-65	4.2(42)

外型尺寸 DIMENSIONS

Model	A (g6)	A1	B	C	D	D1	E	F	G	H
SCB-52	175	110	84.5	25	152	95	7	53	24.5	17
SCB-65	192	130	94	30	169	114	9	66	26.5	20

Model	J	K	L	L1	M	N	P	Q	R	S
SCB-52	10	51.5	4~M10	12	4.2	P7	3~M6x12	160	42	69.5
SCB-65	10	61.5	4~M10	12.5	4.2	P7	3~M6x12	175	50	77



- 可用於前推式或後拉式設計的筒夾夾頭。
- 平順與接近全包覆夾持的特性，擁有更好的夾持力，且不容易傷害工件。
- 搭配單一對應工件尺寸。
- 單一規格夾持範圍可達±0.5mm。
- 更換快速方便。
- 防塵防屑設計。
- Rubber grip collet for push type or draw type collet chucks.
- Full gripping area: high rigidity, more gripping force. Gripping smoothly: prevent to damage the workpiece.
- More accurate than standard spring collets. Accuracy: With customized rubber grip collet.
- Grip Range: ±0.5mm.
- Quick change and easy.
- Dust-proof and swarf-proof design.

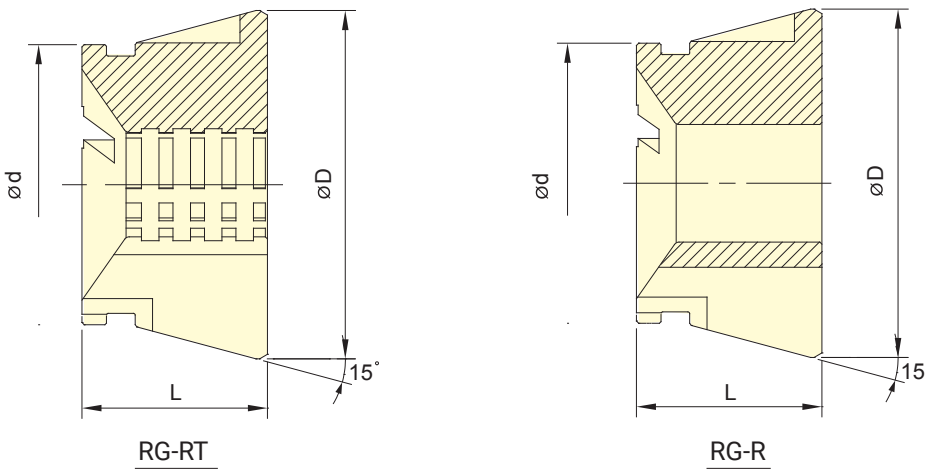

保留規格修改的權利
Subject to technical changes

技術規格 SPECIFICATIONS

型號 Model	最大夾持能力 Max. Chucking Capacity 圓棒 Round mm	d	D	L	適合筒夾夾頭
					Matching Collect Chuck
RG-42R	4~42	54	79.3	42	CB-42, CBE-42
RG-42RT	11~42	54	79.3	42	CB-42, CBE-42
RG-52R	4~52	66	79.3	46	CB-52, CBD-52, CBE-52, SCB-52
RG-52RT	11~52	66	79.3	46	CB-52, CBD-52, CBE-52, SCB-52
RG-65R	4~65	80	99.5	53	CB-65, CBD-65, CBE-65, SCB-65
RG-65RT	11~65	80	99.5	53	CB-65, CBD-65, CBE-65, SCB-65

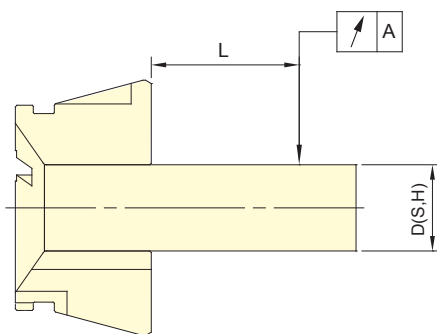

測棒 D(S,H)	L	A DIN	
Test Bar D(S,H)	mm	Class1	Class2
3.0~6.0	16	0.015	0.020
6.0~10.0	25	0.015	0.020
10.0~18.0	40	0.020	0.030
18.0~24.0	50	0.020	0.030
24.0~30.0	60	0.020	0.030
30.0~50.0	80	0.030	0.040
50.0~60.0	100	0.030	0.040

註 1：一般內筒夾精度為 DIN 二級

註 2：本公司橡膠筒夾以 DIN 一級為標準

Note1: Collets chuck are conformed to DIN 6343 Class2.

Note2: AUTOGRIP's rubber grip collets are conformed to DIN 6343 Class1.

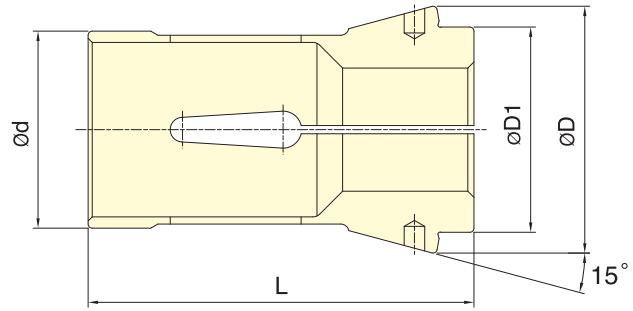

DIN 6343 Collet standard
筒夾規範

保留規格修改的權利
Subject to technical changes

外型尺寸 DIMENSIONS

彈性筒夾 Collet	最大夾持能力 Max. Chucking Capacity (mm)			d	D	D1	L	適合筒夾夾頭
	圓棒 Round	六角材 Hexagom	方材 Square					Matching Collet Chuck
161E	3~26	4~22	4~18	32	45	34	75	CL-26, CL-26A4
163E	3~30	4~26	4~20	35	48	38	80	CL-30, CL-30A4
171E	3~36	6~32	6~26	42	55	42	94	CL-36, CL-36A5
173E	3~42	6~36	6~29	48	60	50	94	CL-42, CL-42A5, CL-42A6
177E	5~52	8~45	7~36	58	70	60	94	CL-52, CL-52A6
185E	5~60	8~52	7~42	66	84	73	110	CL-6017, CL-6022, CL-60A6, CL-60A8
193E	20~80	18~69	15~56	90	107	92	130	CL-80, CL-80A8

測棒D(S,H)	L mm	A DIN	
		Class 1	Class 2
0.5~1.0	3	0.015	0.015
1.0~1.6	6	0.015	0.020
1.6~3.0	10	0.015	0.020
3.0~6.0	16	0.015	0.020
6.0~10.0	25	0.015	0.020
10.0~18.0	40	0.020	0.030
18.0~24.0	50	0.020	0.030
24.0~30.0	60	0.020	0.030
30.0~50.0	80	0.030	0.040
50.0~60.0	100	0.030	0.040

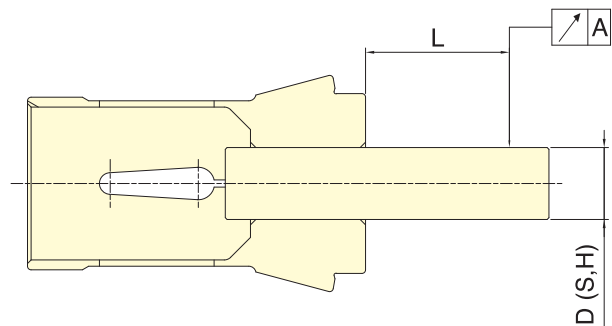

註：一般內筒夾 精度為 DIN 二級
Note: Collets chuck are conformed to DIN 6343 Class2.