

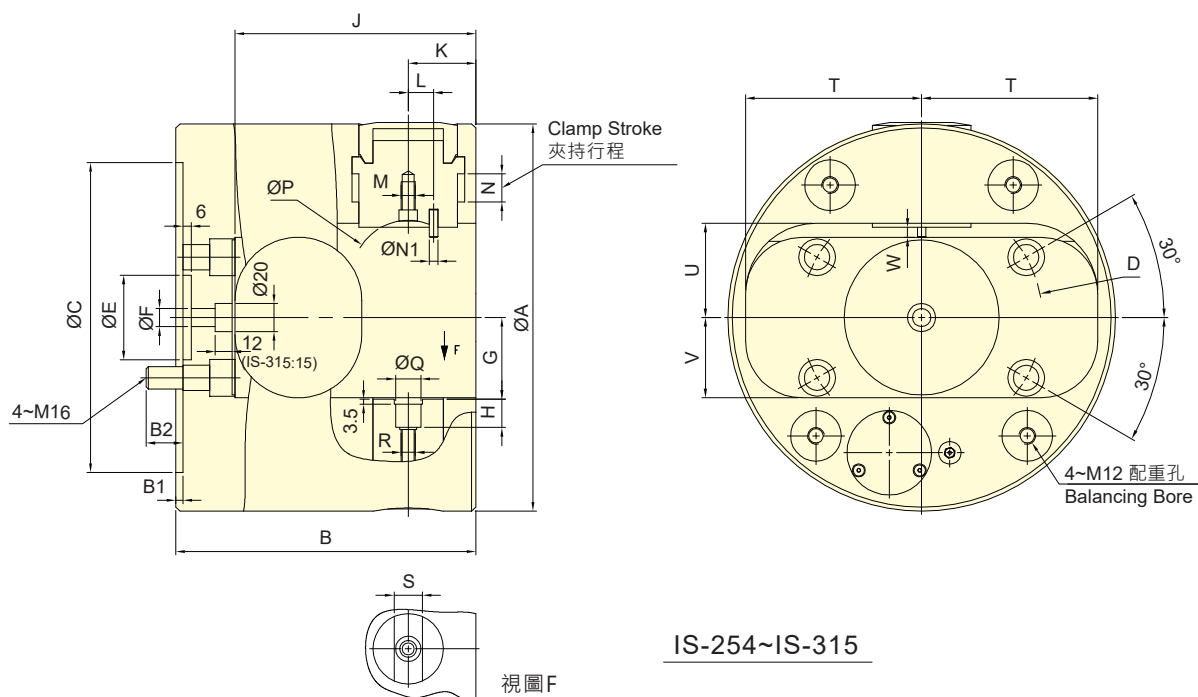

- 主軸運轉過程中進行分度操作，可於多個工作軸之間進行快速轉換。
- 夾頭內部零件均經硬化及精密研磨，並直接潤滑。
- 防水及防切屑設計。
- 高剛性結構及高重複精度。
- 獨特的分度系統及液壓系統，夾頭有壓力檢知機構，可靠性高。
- Indexing operates during the spindle rotation, can perform a quick change between multiple working axes.
- All parts of chuck hardened, ground and lubricated directly.
- Sealed against swarf, chips and coolant.
- High rigidity and high repeatability precision.
- Unique indexing system and hydraulic system, with pressure detection device in chuck, high reliability.



IS-254~IS-315

保留規格修改的權利  
Subject to technical changes

### 技術規格 SPECIFICATIONS

型號	分度角度	爪行程	夾持範圍 Chuckling Area		容許油壓壓力	最大夾持力	最高迴轉數	I	重量	油壓迴轉接頭組	主軸內孔
Model	Index Angle	Jaw stroke	直徑Dia	長度Len	Max. pressure	Max. Clamping force	Max. speed	Moment of inertia	Weight	ROTATING JOINT	Main Spindle Bore
	Deg		mm	mm							
IS-254	4x90°	20	65	160	45	19.5(1990)	1700	0.41	41	IS-315	70 以上
IS-275	4x90°	20	80	220	45	25.4(2590)	1500	0.61	52	IS-315	70 以上
IS-315	4x90°	20	100	230	45	25.0(2550)	1200	1.13	76	IS-315	70以上

### 外型尺寸 DIMENSIONS

Model	A	B	B1	B2	C(H6)	D	E	F	G	H	J	K
IS-254	254	190	5	23	220	171.4	60	13	47.5	18	155	48
IS-275	275	213	5	26	220	171.4	60	13	58	20	171	48
IS-315	315	232	5	22	220	171.4	60	13	71	18.5	187	50

Model	L	M	N	N1	P	Q(H7)	R	S(H7)	T	U	V	W
IS-254	13	M8	20	5	40	18	M10	20	106	57	46.5	5.5
IS-275	18	M10	20	6	80	18	M10	20	125	67	57	7
IS-315	18	M10	20	6	75	24	M12	25	125	85	70	7.5

\* 分度角度 8x45° 或特殊的角度，請逕洽本公司業務部。\*Index Angle 8x45° or Specific Angle, Please contact AUTOGRIP for more detailed information.Thanks.



- 中心防塵蓋端面經研磨處理，可做為工件或治具的基準靠模面。
- 內斜式主爪滑道(具有軸向行程的後拉效果)，改善工具夾持上浮情況，並可使用標準生爪。
- The surface of the center through cover is grinding treated, it can be the position base surface of the jig/workpiece.
- The slideway of main jaws is inclined. It improves the clamping force and reduces the upfloat situation of the workpiece.
- Work with standard top jaws.
- 氣密檢知 (選配)。
- 只能用於工件外夾。
- Airtight pressure detect function is optional.
- External gripping only.

特殊動力夾頭

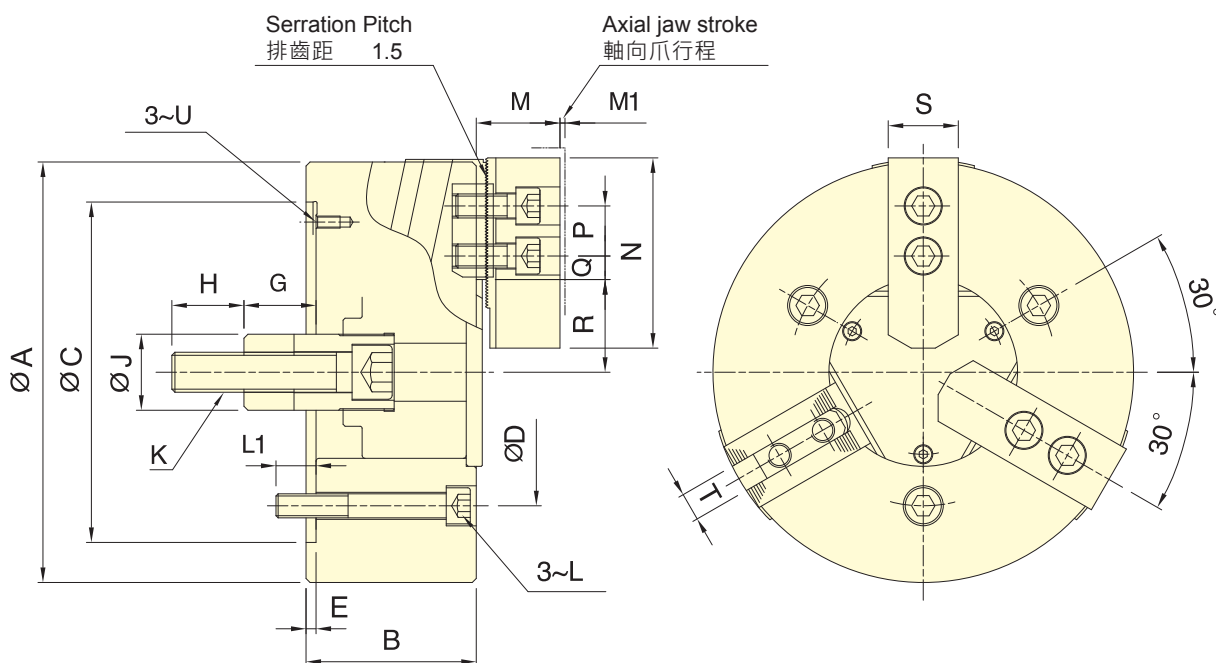

保留規格修改的權利  
Subject to technical changes

### 技術規格 SPECIFICATIONS

型號	模心行程	爪行程 (直徑)	夾持直徑 Chuck Dia.		容許最大入力	最大夾持力	最高迴轉數	I	重量	適用迴轉缸	最大使用壓力
			最大 Max.	最小Min.							
Model	Plunger stroke	Jaw stroke (Dia.)	mm	mm	kN (kgf)	kN (kgf)	min <sup>-1</sup> (r.p.m.)	kg · m <sup>2</sup>	kg		MPa (kgf/cm <sup>2</sup> )
3N-06	20	8.1 (軸向 0.9)	165	14	18 (1835)	61.5 (6270)	5000	0.05	11.1	RK-100(N)	2.6 (26)
3N-08	23	9.4 (軸向 1.0)	210	17	25 (2540)	85.8 (8750)	4500	0.14	24.5	RK-125(N)	2.2 (22)
3N-10	25	10.2 (軸向 1.1)	254	22	29 (2950)	108 (11000)	4000	0.32	34.5	RK-150(N)	1.8 (18)

### 外型尺寸 DIMENSIONS

Model	A	B	C(H6)	D	E	G max.	G min.	H	J	K	L
3N-06	165	72	140	104.8	5	54.5	34.5	36	34	M16x2	M10
3N-08	210	85	170	133.4	5	59	36	36	38	M20x2.5	M12
3N-10	254	89	220	171.4	5	63	38	36	45	M20x2.5	M16

  

Model	L1	M	M1	N	P	Q max.	Q min.	R max.	R min.	S	T	U
3N-06	16	41	0.9	73	20	15.25	7.75	38.3	34.25	31	12	M6
3N-08	20	42	1.0	95	25	22.25	11.75	46.3	41.6	35	14	M6
3N-10	24	47	1.1	110	30	33.75	11.25	52.1	47	40	16	M8

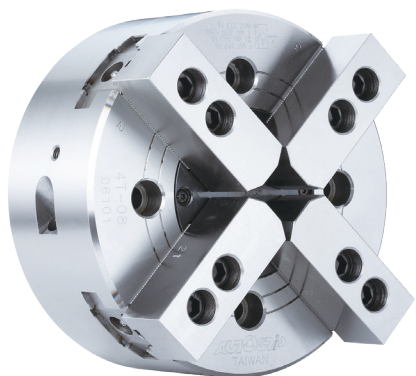

- 曲柄型雙副兩爪各自動作之特殊夾頭。
  - 特別適用方形材或其他非規則形狀的工件。
  - CRANK type with two pairs of 2 jaws self center independent of each other.
  - The 4T series is suitable for square bar and other nonuniform shaped workpieces.
- 專利產品字號 Patent numbers :  
 台灣 : PAT.NO.M359385 (Taiwan)  
 大陸 : PAT.NO.ZL200920009309.1(China)

特殊動力夾頭

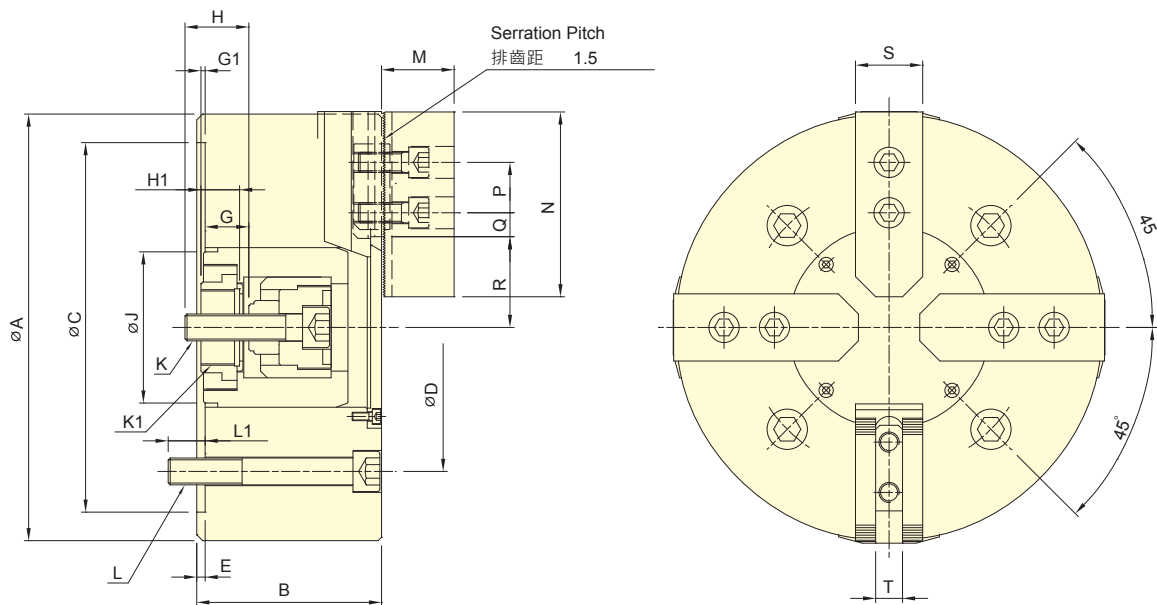

保留規格修改的權利  
Subject to technical changes

### 技術規格 SPECIFICATIONS

型號 Model	楔行程 Plunger stroke mm	爪行程 (直徑) Jaw stroke (Dia.) mm	夾持範圍 Chucking Range		容許最大入力 Max. D.B. pull kN (kgf)	最大夾持力 Max. Clamping force kN (kgf)	最高迴轉數 Max. speed min <sup>-1</sup> (r.p.m.)	I Moment of inertia kg · m <sup>2</sup>	重量 Weight kg	適用迴轉缸 Matching cyl.	最大使用壓力
			最大 Max. mm	最小 Min. mm							MPa (kgf/cm <sup>2</sup> )
4T-08	17	13.6	210	24	16.0(1630)	54.3(5540)	3000	0.15	23.2	RD-120(N)	1.7(17)
4T-10	20	16	254	50	21.6(2200)	79.4(8100)	2100	0.35	44.3	RD-125(N)	2.2(22)
4T-12	20	16	304	50	21.6(2200)	79.4(8100)	1500	0.66	57.6	RD-125(N)	2.2(22)
4T-15	25	19.6	381	60	27.2(2780)	105.3(10750)	1200	2.25	118.3	RD-125(N)	2.7(27)

### 外型尺寸 DIMENSIONS

Model	A	B	C(H6)	D	E	G max.	G min.	G1 max.	G1 min.	H	H1	J	K
4T-08	210	91	170	133.4	5	32	15	2.5	-14.5	29	20	61	M14x2
4T-10	254	110	220	171.4	5	36.5	16.5	10	-10	36	23	90	M16x2
4T-12	304	110	220	171.4	5	36.5	16.5	10	-10	36	23	90	M16x2
4T-15	381	135	300	235	6	44.5	19.5	5	-20	45	28	110	M20x2.5

Model	K1	L	L1	M	N	P	Q max.	Q min.	R max.	R min.	S	T
4T-08	M34x1.5	4~M2	20	38	95	25	25.25	13.25	46.1	39.3	35	14
4T-10	M45x1.5	4~M16	25	43	110	30	32.25	12.75	59	51	40	16
4T-12	M45x1.5	4~M16	25	43	110	30	54.75	15.75	59	51	40	16
4T-15	M55x2	4~M20	30	51	130	30	66.5	12.5	78.9	69.1	50	21



- 可同時將工件做徑向夾持與軸向後拉，使工件不上浮並緊貼座金基準面。
  - 高剛性硬化處理的本體與圓柱後拉機構，並經過軸孔精搪，確保夾持精度與耐用度。
  - Radial clamp and axial pull down at the same time, keep the workpiece attaching close to the base surface of the chuck.
  - Almost no workpiece uplifting displacement.
  - The body and the cylinder pull-down mechanism are heat-treated and fine boring, which guarantee the clamping precision and durability.
- 氣密檢知 (選配)。  
■ Airtight pressure detect function is optional.

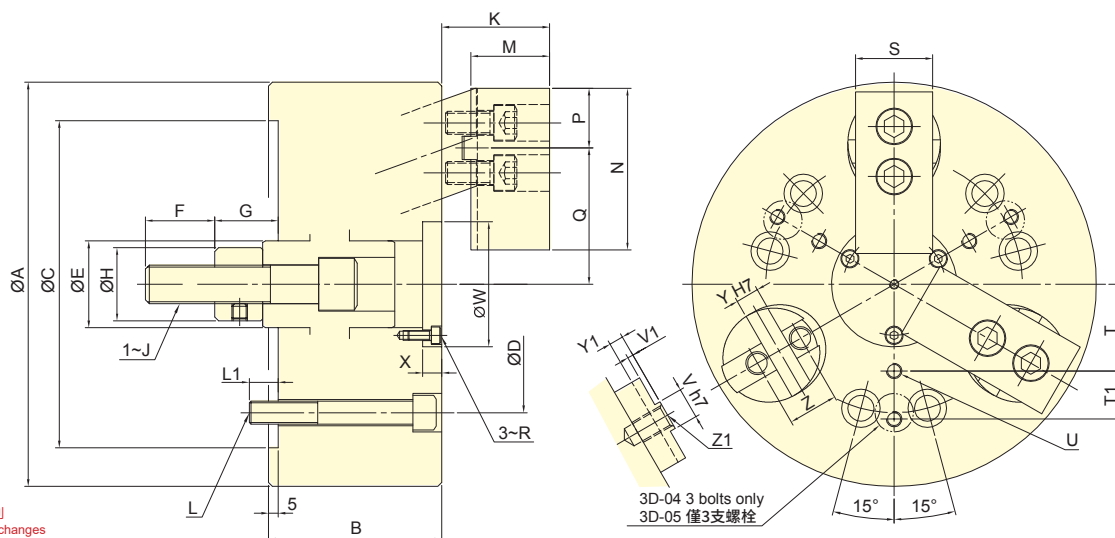

保留規格修改的權利  
Subject to technical changes

### 技術規格 SPECIFICATIONS

型號	楔心行程	爪行程 (直徑)	夾持直徑 Chucking Dia.		容許最大入力	最大夾持力	最高迴轉數	I	重量	適用迴轉缸	最大使用壓力
Model	Plunger stroke	Jaw stroke (Dia.)	最大 Max.	最小 Min.	Max. D.B. pull	Max. Clamping force	Max. speed	Moment of inertia	Weight	Matching cyl.	Max. pressure
	mm	mm	mm	mm	kN (kgf)	kN (kgf)	min <sup>-1</sup> (r.p.m.)	kg · m <sup>2</sup>	kg		MPa (kgf/cm <sup>2</sup> )
3D-04	7	5	110	13	6.0(612)	10.5(1070)	3500	0.007	4.5	RK-75	1.6(16.5)
3D-05	7	5	135	21	10.0(1020)	17.0(1730)	3500	0.018	7.9	RK-75	2.7(27.5)
3D-06	10	7.2	165	22	15.0(1530)	25.0(2550)	3500	0.051	15	RK-100	2.1(21.4)
3D-08	10	7.2	210	28	25.0(2550)	45.0(4590)	3000	0.15	26	RK-125	2.2(22.5)
3D-10	15	10.8	254	35	35.0(3569)	60.0(6118)	2500	0.37	46	RK-125	3.1(31.6)
3D-12	15	10.8	304	50	45.0(4590)	75.0(7650)	2000	0.79	70	RK-150	2.8(28.5)
3D-15	20	14.5	381	60	53.9(5500)	90.0(9180)	1500	2.25	132	RK-150	3.4(34.2)

### 外型尺寸 DIMENSIONS

Model	A	B	C (H6)	D	E	F	G max.	G min.	H	J	K max.	K min.	L	L1	M	N	P
3D-04	110	60	85	70.6	25	20	22	15	25	M10	30	23	3~M10	15	19.5	50	22
3D-05	135	70	110	82.6	30	25	24	17	28	M12	35	28	3~M10	16	24.5	56	23
3D-06	165	85	140	104.8	35	36	37	27	32	M16	45	35	6~M10	16	31	70	27
3D-08	210	90	170	133.4	45	36	38	28	38	M20	56	46	6~M12	15	41	84	31
3D-10	254	110	220	171.4	55	46	47	32	50	M24	65	50	6~M16	24	46	100	38
3D-12	304	125	220	171.4	55	50	49.5	34.5	53	M27	70	55	6~M16	22	51	120	42
3D-15	381	140	300	235	70	55	61	41	55	M30	86	66	6~M20	30	60	165	60

Model	Q max.	Q min.	R	S	T	T 1	U	V (h7)	V 1	W	X	Y(H7)	Y1	Z	Z1
3D-04	37	34.5	M3	25	22.5	-	3~M6	8	2.5	35	2	8	6	-	M10
3D-05	46	43.5	M3	30	27.5	-	3~M6	8	2.5	44	2	8	6	-	M12
3D-06	57.7	54.3	M4	35	35	20	6~M6	10	2.5	52	7	10	6.5	-	M14
3D-08	70.8	67.2	M5	40	45	25	6~M8	16	3	65	10	12	7.5	26	M12
3D-10	85	79.6	M6	50	55	30	6~M8	18	3	75	12	15	7.5	32	M14
3D-12	101.9	96.5	M6	60	70	35	6~M10	20	3	90	12	17	7.5	36	M16
3D-15	135.6	128.3	M8	70	95	45	6~M12	24	4	120	13	20	6	40	M16

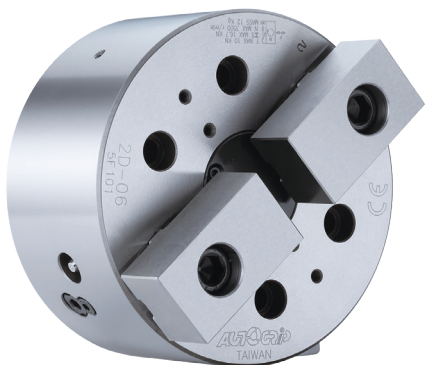

- 可同時將工件做徑向夾持與軸向後拉，使工件不上浮並緊貼座金基準面。
- 高剛性硬化處理的本體與圓柱後拉機構，並經過軸孔精搪，確保夾持精度與耐用度。
- Radial clamp and axial pull down at the same time, keep the workpiece attaching close to the base surface of the chuck.
- Almost no workpiece uplifting displacement.
- The body and the cylinder pull-down mechanism are heat-treated and fine boring, which guarantee the clamping precision and durability.
- 氣密檢知 (選配)。
- Airtight pressure detect function is optional.

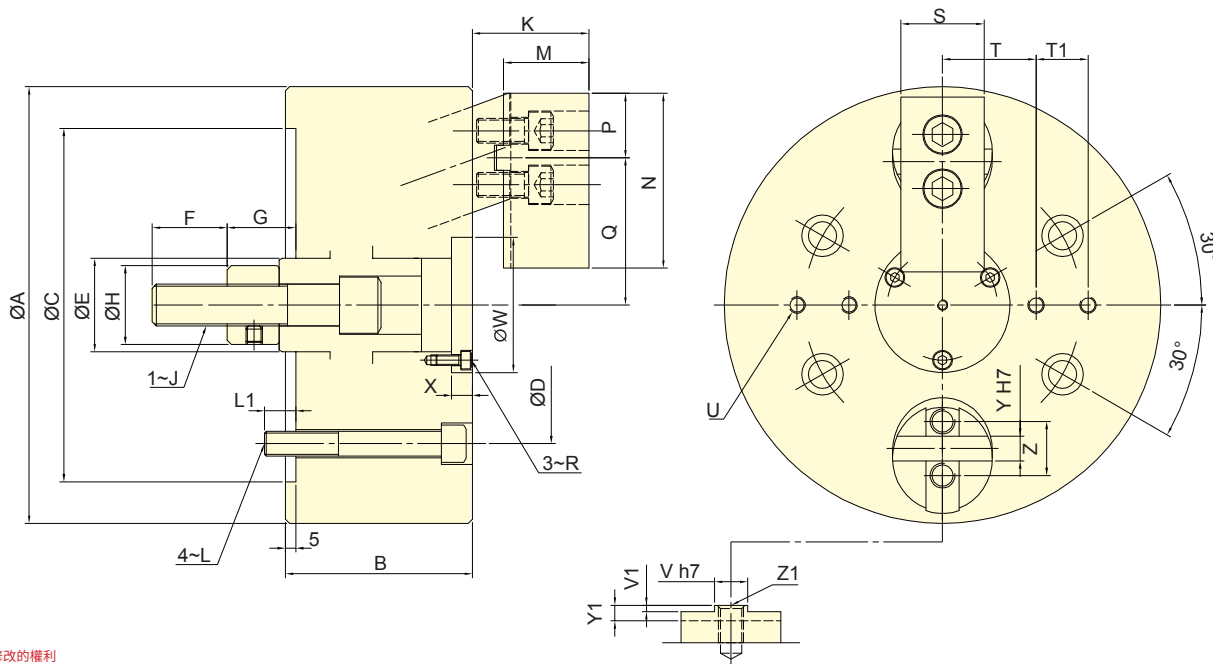

保留規格修改的權利  
Subject to technical changes

### 技術規格 SPECIFICATIONS

型號	楔心行程	爪行程 (直徑)	夾持直徑		容許最大入力	最大夾持力	最高迴轉數	I	重量	適用迴轉缸	最大使用壓力
			最大	最小							
Model	Plunger stroke	Jaw stroke (Dia.)	Max.	Min.	Max. D.B. pull	Max. Clamping force	Max. speed	Moment of inertia	Weight	Matching cyl.	Max. pressure
	mm	mm	mm	mm	kN (kgf)	kN (kgf)	min <sup>-1</sup> (r.p.m.)	kg · m <sup>2</sup>	kg		MPa (kgf/cm <sup>2</sup> )
2D-06	10	7.2	165	22	10.0(1020)	16.7(1700)	3500	0.045	12	RK-100	1.4(14.3)
2D-08	10	7.2	210	28	16.7(1700)	30.0(3060)	3500	0.13	23	RK-125	1.5(15)
2D-10	15	10.8	254	35	23.3(2379)	40.0(4079)	2500	0.34	43	RK-125	2.1(21.1)

### 外型尺寸 DIMENSIONS

Model	A	B	C (H6)	D	E	F	G max.	G min.	H	J	K max.	K min.	L	L1	M	N	P
2D-06	165	85	140	104.8	35	36	37	27	32	M16	45	35	M10	16	31	70	27
2D-08	210	90	170	133.4	45	36	38	28	38	M20	56	46	M12	15	41	84	31
2D-10	254	110	220	171.4	55	46	47	32	50	M24	65	50	M16	24	46	100	38

  

Model	Q max.	Q min.	R	S	T	T1	U	V (h7)	V1	W	X	Y (H7)	Y1	Z	Z1
2D-06	57.7	54.3	M4	35	35	20	4~M6	10	2.5	52	7	10	6.5	-	M14
2D-08	70.8	67.2	M5	40	45	25	4~M8	16	3	65	10	12	7.5	26	M12
2D-10	85	79.6	M6	50	55	30	4~M8	18	3	75	12	15	7.5	32	M14

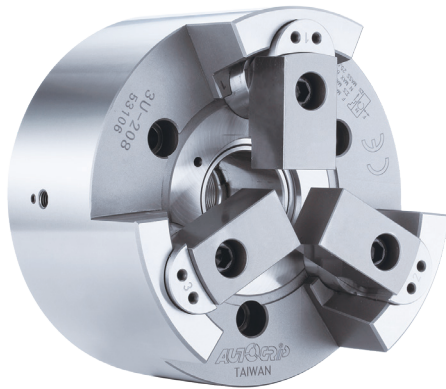

- 銷柱後拉型三爪中空夾頭。
- 高夾持力及高精度。
- 特別適合使用於需要重切削的場合。
- Pin-Arbor Draw Down type 3-jaw thru-hole power chuck.
- High radial gripping force and high accuracy.
- Suitable for heavy machining.

特殊動力夾頭

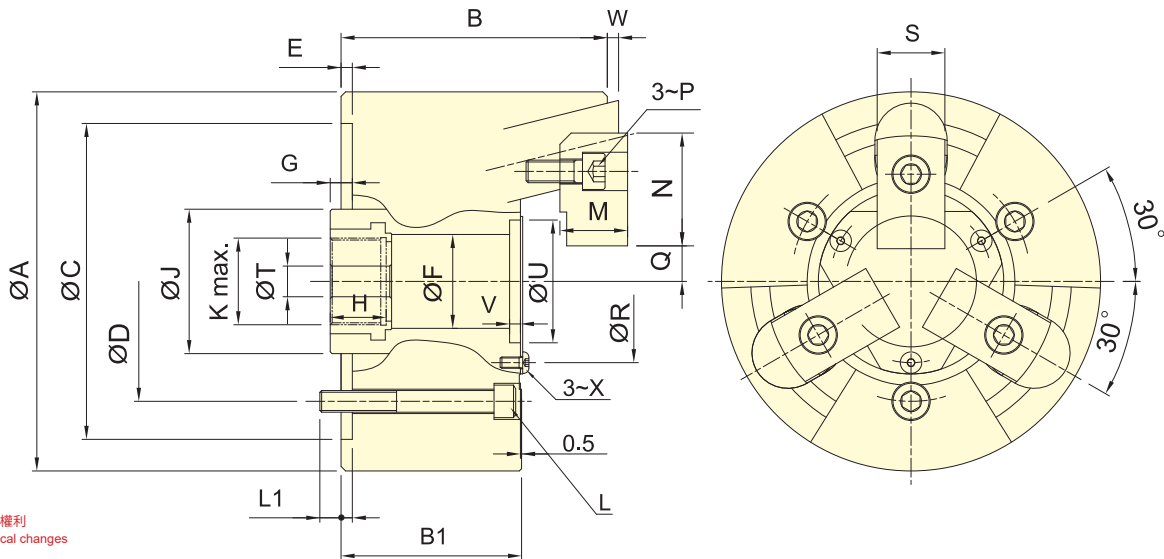

保留規格修改的權利  
Subject to technical changes

### 技術規格 SPECIFICATIONS

型號 Model	楔心行程 Plunger stroke mm	爪行程 (直徑) Jaw stroke (Dia.) mm	夾持直徑 Chucking Dia.		容許最大入力 Max. D.B. pull kN (kgf)	最大夾持力 Max. Clamping force kN (kgf)	最高迴轉數 Max. speed min <sup>-1</sup> (r.p.m.)	I Moment of inertia kg · m <sup>2</sup>	重量 Weight kg	適用迴轉缸 Matching cyl.	最大使用壓力 Max. pressure MPa (kgf/cm <sup>2</sup> )
			最大 Max.	最小 Min.							
3U-203	4	2	42	14	5.8(590)	16.7(1700)	10000	0.001	1.8	RK-75(N)	1.6(16)
3U-204	6	3	60	10	10.0(1020)	28.4(2900)	8000	0.005	3.9	RK-75(N)	2.7(27)
3U-205	6	3	84	15	13.9(1420)	39.7(4050)	8000	0.012	6.8	RK-100(N)	2.0(20)
3U-206	10	5	105	24	17.9(1830)	57.8(5900)	7000	0.055	14.7	RK-100(N)	2.6(26)
3U-208	12	6	132	25	25.0(2550)	80.0(8150)	6000	0.14	25.5	RK-125(N)	2.2(22)
3U-210	10	5	163	34	31.0(3160)	100.0(10100)	4500	0.36	43.5	RK-125(N)	3.1(31)
3U-212	10	5	210	81	35.0(3570)	100.0(10100)	3600	0.68	63.0	RK-125(N)	3.1(31)

### 外型尺寸 DIMENSIONS

Model	A	B	B1	C(H6)	D	E	F	G max.	G min.	H	J	K	L	L1
3U-203	85	54.5	42	70	54	3.5	25	18	14	22	38	M20x1.5	3~M8	11
3U-204	110	72.5	55	85	70.6	4	30	16	10	24.5	42	M24x1.5	3~M10	12
3U-205	135	84.5	63	110	82.6	4	35	16	10	26	50	M28x1.5	3~M10	15
3U-206	168	118	80	140	104.8	5	45	20	10	31	60	M38x1.5	3~M10	16.5
3U-208	210	137	92	170	133.4	5	52	23	11	31	80	M48x2	3~M12	18
3U-210	254	152	102	220	171.4	5	75	25	15	37	105	M68x2	3~M16	23
3U-212	304	157	102	220	171.4	5	100	25	15	37	135	M92x2	3~M16	26

Model	M	N	P	Q max.	Q min.	R	S	T	U(H6)	V	W max.	W min.	X
3U-203	12	26	M5	7.5	6.5	38	15	10	32	3.5	2	-2	M3
3U-204	17	40	M6	10.75	9.25	46	20	10	38	4	3	-3	M4
3U-205	20	41.5	M8	13.25	11.75	55	24	10	45	5	3	-3	M5
3U-206	30	50	M10	15.75	13.25	72	30	17	58	6	5	-5	M5
3U-208	34	63	M12	16.25	13.25	82	35	17	68	6	5	-7	M6
3U-210	39	74	M14	20.75	18.25	107	40	17	93	6	5	-5	M8
3U-212	44	74	M14	44.25	41.75	130	40	17	114	6	5	-5	M10

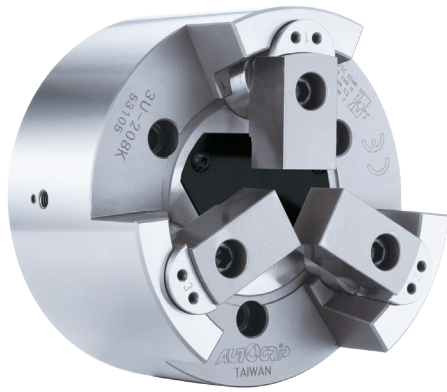

- 銷柱後拉型三爪中實夾頭。
- 高夾持力及高精度。
- 特別適合使用於需要重切削の場合。
- 可配合氣密檢知，進行軸向位置確認，適合長度尺寸精度的要求。
- Pin-Arbor Draw Down type 3-jaw non-thru-hole power chuck.
- High radial gripping force and high accuracy.
- Suitable for heavy machining.
- Can work with the airtight detection device to perform axial position confirm, suitable for the precision of large length size process.

特殊動力夾頭

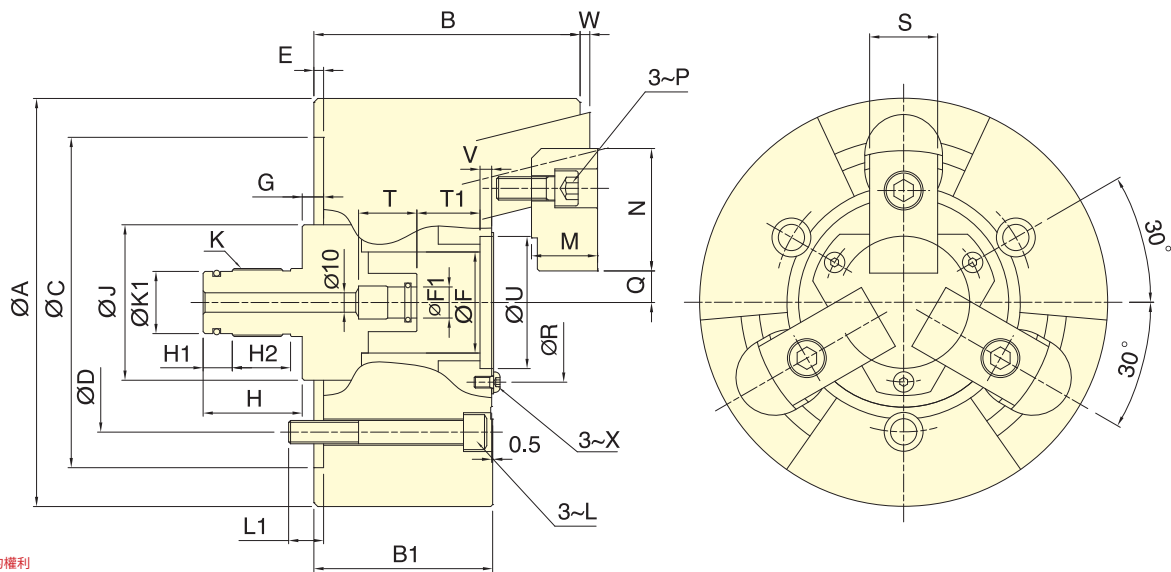

保留規格修改的權利  
Subject to technical changes

### 技術規格 SPECIFICATIONS

型號	楔行程	爪行程 (直徑)	夾持直徑 Chuck Dia.		容許最大入力	最大夾持力	最高迴轉數	I	重量	適用迴轉缸	最大使用壓力
Model	Plunger stroke	Jaw stroke (Dia.)	最大 Max.	最小 Min.	Max. D.B. pull	Max. Clamping force	Max. speed	Moment of inertia	Weight	Matching cyl.	Max. pressure
	mm	mm	mm	mm	kN (kgf)	kN (kgf)	min <sup>-1</sup> (r.p.m.)	kg · m <sup>2</sup>	kg		MPa (kgf/cm <sup>2</sup> )
3U-205K	6	3	84	15	13.9(1420)	39.7(4050)	8000	0.018	6.8	RL-100, RL-A100N	2.0(20)
3U-206K	10	5	105	24	17.9(1830)	57.8(5900)	7000	0.055	14.9	RL-100, RL-A100N	2.5(25)
3U-208K	12	6	132	25	25.0(2550)	80.0(8150)	6000	0.14	25.8	RL-125, RL-A125N	2.2(22)
3U-210K	10	5	163	34	31.0(3160)	100(10100)	4500	0.36	44.0	RL-125, RL-A125N	3.1(31)
3U-212K	10	5	210	81	35.0(3570)	100(10100)	3600	0.68	63.8	RL-125, RL-A125N	3.1(31)

### 外型尺寸 DIMENSIONS

Model	A	B	B1	C(H6)	D	E	F	F1(H8)	G max.	G min.	H	H1	H2	J	K	K1	L
3U-205K	135	84.5	63	110	82.6	4	35	14	16	10	42	12	-	50	M25x1.5	22	M10
3U-206K	168	118	80	140	104.8	5	45	14	20	10	48	12	30	60	M28x1.5	24	M10
3U-208K	210	137	92	170	133.4	5	52	16	23	11	51	15	30	80	M35x1.5	30	M12
3U-210K	254	152	102	220	171.4	5	75	16	25	15	51	15	30	105	M38x1.5	34	M16
3U-212K	304	157	102	220	171.4	5	100	16	25	15	51	15	30	135	M45x1.5	40	M16

Model	L1	M	N	P	Q max.	Q min.	R	S	T	T1	U(H6)	V	W max.	W min.	X
3U-205K	15	20	41.5	M8	13.25	11.75	55	24	25	15.5	45	5	3	-3	M5
3U-206K	16.5	30	50	M10	15.75	13.25	72	30	30	26.5	58	6	5	-5	M5
3U-208K	18	34	63	M12	16.25	13.25	82	35	30	32.5	68	6	5	-7	M6
3U-210K	23	39	74	M14	20.75	18.25	107	40	30	36.5	93	6	5	-5	M8
3U-212K	26	44	74	M14	44.25	41.75	130	40	30	36.5	114	6	5	-5	M10



- 適用於內徑夾持。
- 可同時將工件做徑向夾持與軸向後拉，使工件不上浮並緊貼座金基準面。
- 高精度安定性，適合最後製程加工。
- Suitable for internal gripping.
- Radial clamp and axial pull down at the same time, keep the workpiece attaching close to the base surface of the chuck.
- Almost no workpiece uplifting displacement.
- With high precision and stability that chuck suitable for end process.
- 氣密檢知 (選配)。
- Airtight pressure detect function is optional.

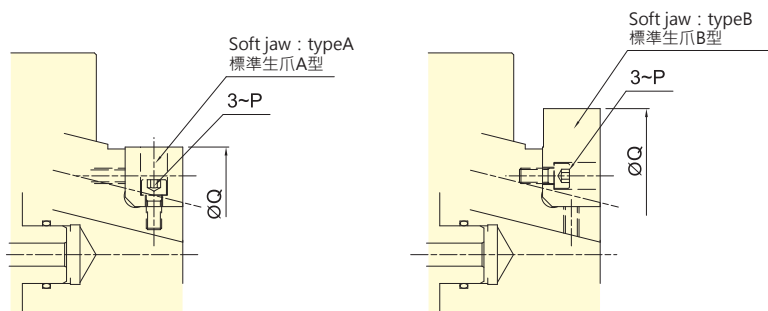
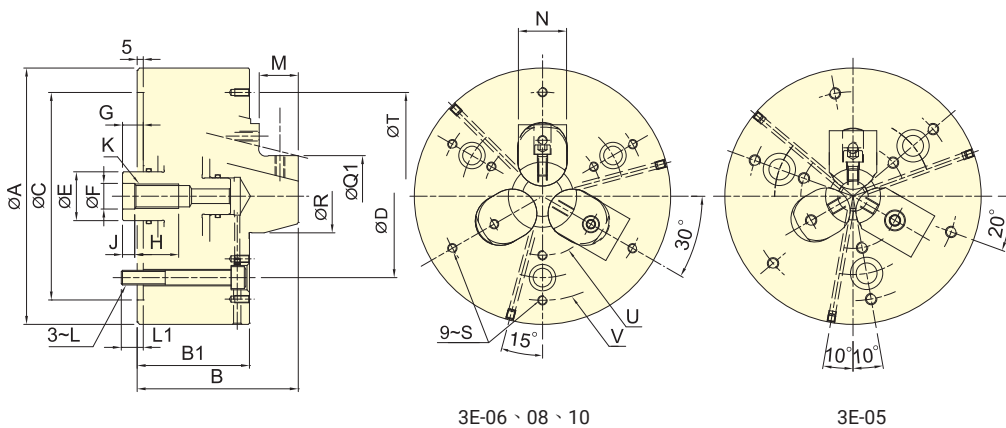

保留規格修改的權利  
Subject to technical changes

### 技術規格 SPECIFICATIONS

型號	楔心行程	爪行程 (直徑)	夾持直徑 Chucking Dia.		容許最大入力	最大夾持力	最高迴轉數	I	重量	適用迴轉缸	最大使用壓力
Model	Plunger stroke	Jaw stroke (Dia.)	最大Max.	最小Min.	Max. D.B. pull	Max. Clamping force	Max. speed	Moment of inertia	Weight	Matching cyl.	Max. pressure
	mm	mm	mm	mm	kN (kgf)	kN (kgf)	min <sup>-1</sup> (r.p.m.)	kg · m <sup>2</sup>	kg		MPa (kgf/cm <sup>2</sup> )
3E-05	6	3	83	29	13.0(1325)	42.0(4280)	7000	0.018	7.5	RK-100	1.8(18.5)
3E-06	10	5	110	44	18.0(1835)	58.0(5910)	6000	0.042	13.6	RK-100	2.5(25.6)
3E-08	10	5	150	50	25.0(2530)	80.0(8150)	5000	0.14	26.5	RK-125	2.2(22.5)
3E-10	10	5	190	60	35.0(3570)	100.0(10200)	3600	0.31	39.5	RK-150	2.8(28.5)

### 外型尺寸 DIMENSIONS

Model	A	B	B1	C (H6)	D	E	F (H8)	G max.	G min.	H	J	K	L	L1
3E-05	135	98	72	110	82.6	25	18	18	12	25	8	M16	M10	15
3E-06	165	112	80	140	104.8	35	18	22	12	30	8	M16	M10	16
3E-08	210	135	90	170	133.4	40	21	22	12	36	10	M20	M12	18
3E-10	254	152	102	220	171.4	50	25	25	15	48	10	M24	M16	23

Model	M	N	P	type A		type B		Q1		R	S	T	U (p.c.d)	V (p.c.d)
				Q max.	Q min.	Q max.	Q min.	max.	min.					
3E-05	20	25	M6	68	50	83	67	50	29	25	M6x12	110	55	110
3E-06	23	31	M6	90	70	110	89	70	44	40	M6x12	130	76	134
3E-08	30	35	M8	110	90	150	108	90	50	49	M6x12	170	100	170
3E-10	35	40	M10	127	110	190	125	110	60	59	M8x16	210	120	210





特殊動力夾頭

- 三爪擺動夾持工件。(自動求心型 3W)
  - 適合鑄件及鍛件等原材料進行加工。
  - 特別適合使用於需要重切削的場合。
  - 防塵及防切削液密封圈，使保養工作更加便利。
  - 擺動機構零件均以合金鋼加以熱處理硬化及研磨，以提升產品使用壽命。
  - 三爪擺動夾持工件。(定心補償型 3W-C)
  - 工件偏心補償量2mm，中心頂針定位。
- Swing and grasp the workpiece to three jaw. (3W is automatically positioned to the center type.)
  - Suitable for such materials as the casting and forging to process.
  - Suitable for heavy machining.
  - Seal proof for dust and cutting fluid, it is more convenient when maintenance.
  - Swing parts are to heat treatment hardened and ground for steel, in order to improve products service life.
  - Swing and grasp the workpiece to three jaw.(3W-C is center compensation type.)
  - The workpieces compensation of eccentric is 2 mm, fixed position for the center thimble.

- 可搭配鎢鋼爪，根據工件條件選擇鎢鋼爪型式。(選購品)
- 依不同加工需求，外徑夾持可旋轉為內徑夾持。
- Carbide gripper is optional.  
\* The type of the carbide gripper is selected according to the work-piece conditions.
- According to different processing requirements, O.D. Gripping and I.D. Gripping can be interchanged.

### 鎢鋼爪型式 Type of the Carbide gripper

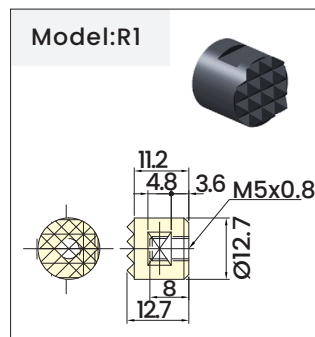
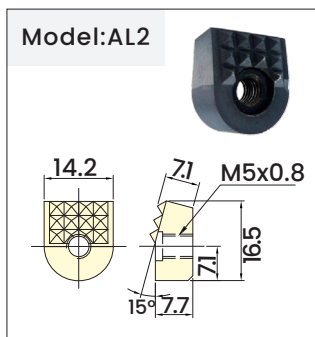
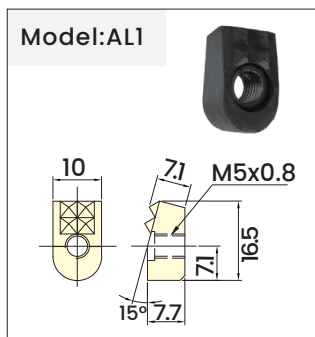

### 外徑夾持 O.D. Gripping

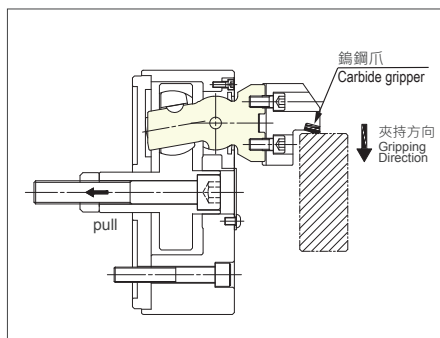

### 內徑夾持 I.D. Gripping

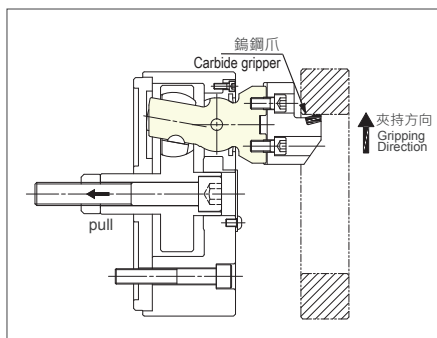

### 最小夾持範圍 Min. Gripping range

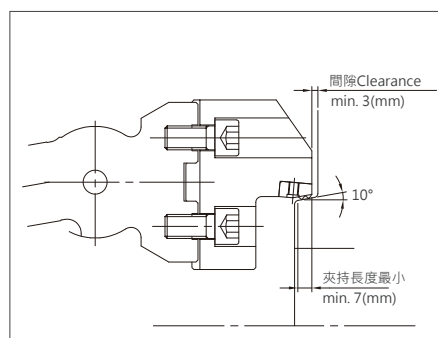

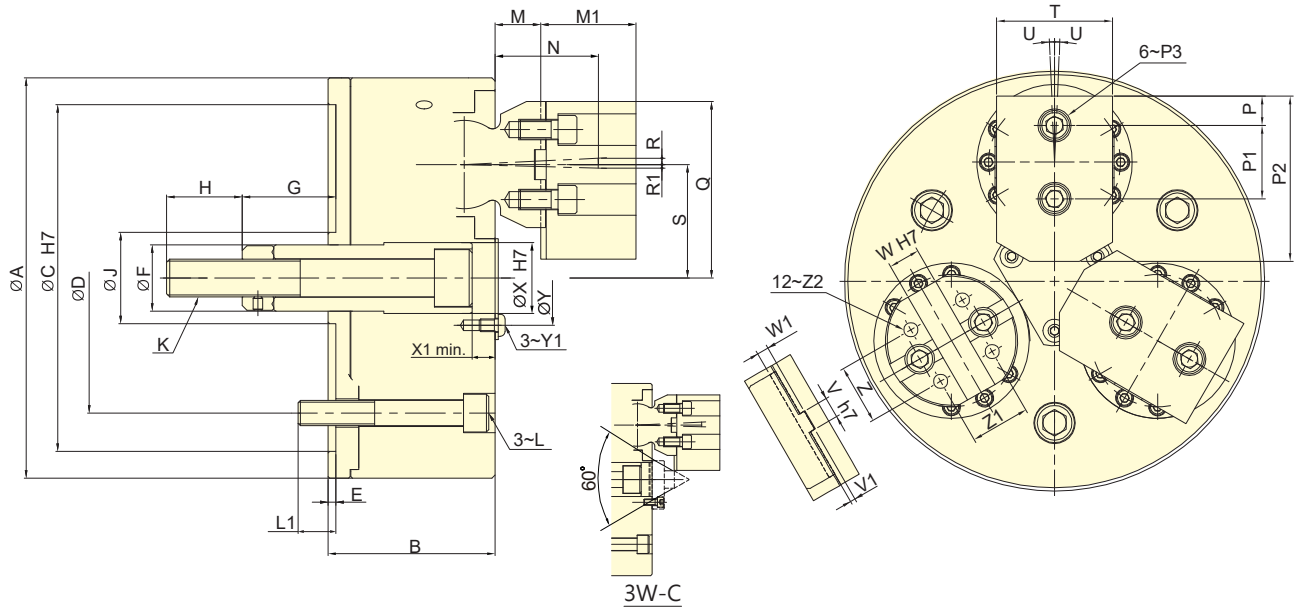

保留規格修改的權利  
Subject to technical changes

### 技術規格 SPECIFICATIONS

型號	楔心行程	爪行程 (直徑)	夾持外徑 Chuck O.D.	夾持內徑 Chuck I.D.	容許最大入力	最大夾持力	最高迴轉數	I	重量	適用迴轉缸	補償量
Model	Plunger stroke	Jaw stroke (Dia.)	最小~最大	最小~最大	Max. D.B. pull	Max. clamping force	Max. speed	Moment of inertia	Weight	Matching cyl.	Compensation
			mm	mm							
3W-08	14.4	9.8	16~150	76~203	25(2550)	85.0(8670)	3700	0.12	23	RK-100(N)	-
3W-C08	14.4	9.8	16~150	76~203	25(2550)	85.0(8670)	3700	0.12	23	RK-100(N)	2
3W-10	17.5	12.5	50~205	85~235	35.3(3600)	105.9(10800)	2500	0.37	48.6	RK-125(N)	-
3W-C10	17.5	12.5	50~205	85~235	35.3(3600)	105.9(10800)	2500	0.37	48.6	RK-125(N)	2
3W-12	17.5	12.5	63~240	127~305	35.3(3600)	105.9(10800)	2400	0.73	65	RK-125(N)	-
3W-C12	17.5	12.5	63~240	127~305	35.3(3600)	105.9(10800)	2400	0.73	65	RK-125(N)	2
3W-15	22.5	15.9	76~317	165~381	56(5600)	168.2(16800)	2000	1.81	97	RK-150(N)	-
3W-C15	22.5	15.9	76~317	165~381	56(5600)	168.2(16800)	2000	1.81	97	RK-150(N)	3

### 外型尺寸 DIMENSIONS

Model	A	B	C (H7)	D	E	F	G max.	G min.	H	J	K	L	L1	M	M1	N	P	P1	P2
3W-08	210	89	170	133.4	5	34	51.9	37.5	40	50	M18x2.5	M12	19	19.3	56.5	52.7	16	38	80
3W-C08	210	89	170	133.4	5	34	51.9	37.5	40	50	M18x2.5	M12	19	19.3	56.5	52.7	16	38	80
3W-10	254	106	220	171.4	5	42	67.5	50	48	58	M24x3	M16	24	29	60.5	65.6	17.8	44.4	100
3W-C10	254	106	220	171.4	5	42	67.5	50	48	58	M24x3	M16	24	29	60.5	65.6	17.8	44.4	100
3W-12	304	106	220	171.4	5	42	67.5	50	48	58	M24x3	M16	24	29	60.5	65.6	17.8	44.4	100
3W-C12	304	106	220	171.4	5	42	67.5	50	48	58	M24x3	M16	24	29	60.5	65.6	17.8	44.4	100
3W-15	381	120	300	235	5	55	62.5	40	46	80	M27x3	M20	30	32.4	72	74.3	19	63.5	140
3W-C15	381	120	300	235	5	55	62.5	40	46	80	M27x3	M20	30	32.4	72	74.3	19	63.5	140

Model	P3	Q	R	R1	S	T	U	V (h7)	V1	W (H7)	W1	X(H7)	X1	Y	Y1	Z	Z1	Z2
3W-08	M12	95	2.69	2.24	60	57	2	7.94	3	12.68	7	34	3.5	46	M6	32	32	M10
3W-C08	M12	95	2.69	2.24	60	57	2	7.94	3	12.68	7	34	3.5	46	M6	32	32	M10
3W-10	M12	112	4.03	2.26	72	70	2.5	12.7	3	19.03	7	45	5	60	M8	36	36	M10
3W-C10	M12	112	4.03	2.26	72	70	2.5	12.7	3	19.03	7	45	5	60	M8	36	36	M10
3W-12	M12	132.5	4.03	2.26	92.5	70	2.5	12.7	3	19.03	7	45	5	60	M8	36	36	M10
3W-C12	M12	132.5	4.03	2.26	92.5	70	2.5	12.7	3	19.03	7	45	5	60	M8	36	36	M10
3W-15	M12	172	5.14	2.83	121	80	2	12.7	3	19.03	7	56	3	90	M8	36	36	M10
3W-C15	M12	172	5.14	2.83	121	80	2	12.7	3	19.03	7	56	3	90	M8	36	36	M10

特殊動力夾頭



特殊動力夾頭

- 工件偏心補償量1mm·中心頂針定位·三爪擺動夾持工件。
- 可以在不反轉工件的情況下進行二次加工·因此大幅減少準備時間。
- 通過補償主爪夾緊進行粗、精加工。內部密封·使維護成本低。
- 搭配雙桿型迴轉缸(3RF-D)。
- 驅動銷推力大小可由迴轉缸壓力控制(3RF-D)。
- The workpiece compensation of eccentric is 1mm, fixed position for the center, swing and grasp the workpiece to three jaw.
- Second machining can be performed without reversing the workpiece, thus significantly reducing setup time.
- With compensating jaws clamping, the Rough and precision machining can be carried out.
- With sealed design, the maintenance costs can be reduced.
- Can be paired with double-rod rotary cylinder (3RF-D type).
- The driver pin thrust can be controlled by the pressure of the rotary cylinder (3RF-D type).

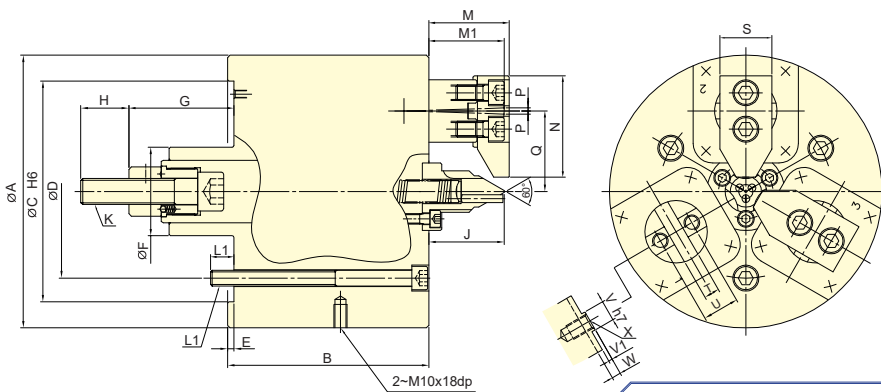

3RF

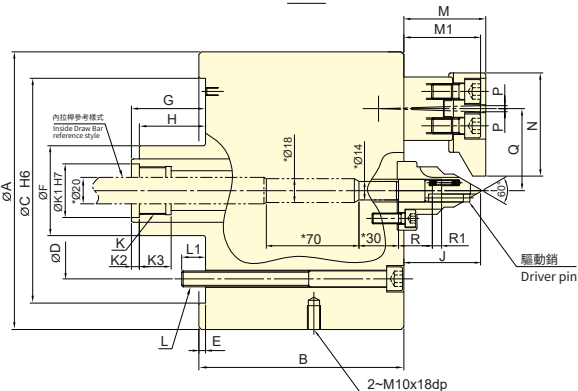

3RF-D

註:標示[\*]之寸法為內拉桿製作之尺寸,請勿任意更改。  
 Note: The dimensions marked [\*] are the dimensions of the inside Draw Bar, Please don't change it.

保留規格修改的權利  
 Subject to technical changes

### 技術規格 SPECIFICATIONS

型號	楔心行程	爪行程 (直徑)	夾持直徑 Chuck Dia.		容許最大入力	最大夾持力	最高迴轉數	I	重量	適用迴轉缸	補償量
			最大	最小							
Model	Plunger stroke	Jaw stroke (Dia.)	Max.	Min.	Max. D.B. pull	Max. clamping force	Max. speed	Moment of inertia	Weight	Matching cyl.	Compensation
	mm	mm	mm	mm	kN (kgf)	kN (kgf)	min <sup>-1</sup> (r.p.m.)	kg · m <sup>2</sup>	kg		mm
3RF-08	43.5	9.4	70	18	39.2 (4000)	39.2 (4000)	4000	0.15	30	RS-1250	1
3RF-08D	43.5	9.4	70	18	39.2 (4000)	39.2 (4000)	4000	0.15	30	RDL-130S	1

### 外型尺寸 DIMENSIONS

Model	A	B	C (H6)	D	E	F	G max.	G min.	H	J	K	K1 (H7)	K2	K3	L	L1
3RF-08	210	155	170	133.4	5	68	123	79.5	37	58	M20x2.5	-	-	-	3~M12	18
3RF-08D	210	155	170	133.4	5	68	98	54.5	50	58	M36x1.5	40.5	6	24	3~M12	18

Model	M	M1	N	P	Q	R	R1 max.	R1 min.	S	T(H7)	U	V	V1	W	X
3RF-08	62	58	78	2.35	62	-	-	-	40	12	28	16	3	7	M12
3RF-08D	62	58	78	2.35	62	25.5	7	0	40	12	28	16	3	7	M12

### 應用說明 APPLICATION NOTES

- 1.加工夾持直徑**  
 補償主爪縮回,工件在中心頂針與尾座頂針間支撐,並透過端面驅動來操作。  
 1.Clamping diameter machining  
 The compensating jaws are retracted. The workpiece is clamped between chuck center and tailstock center. Additionally, it is driven by the face driver.
- 2.粗加工**  
 通過補償主爪夾緊進行粗加工。  
 2.Rough machining  
 With compensating jaws clamping, the rough machining can be carried out.
- 3.精加工**  
 補償主爪縮回,工件在中心頂針與尾座頂針間支撐,並透過端面驅動完成加工,可加工所有的部位,並可達到同心度的要求。  
 3.Finish machining  
 Additionally, it is driven by the face driver. The entire workpiece can be machined with precise concentricity.



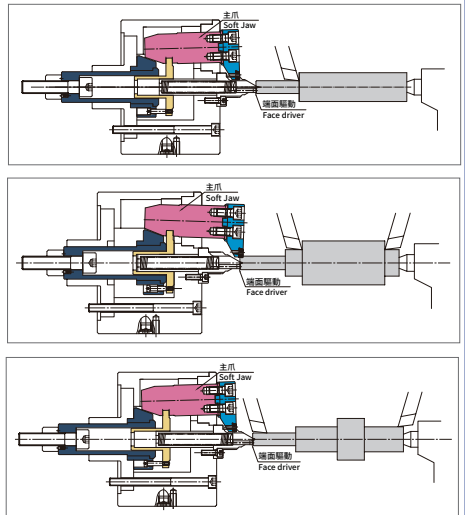

- 工件偏心補償量2mm，中心頂針定位，三爪擺動夾持工件。
- 特殊防水密封圈，防塵及防切削液，使保養工作更加便利。
- 擺動機構零件均以合金鋼加以熱處理硬化及研磨，以提升產品使用壽命。
- The workpieces compensation of eccentric is 2 mm, fixed position for the center thimble, swing and grasp the workpiece to three jaw.
- Special seal proof for dust and cutting fluid, it is more convenient when maintenance.
- Swing parts are to heat treatment hardened and ground for steel, in order to improve products service life.

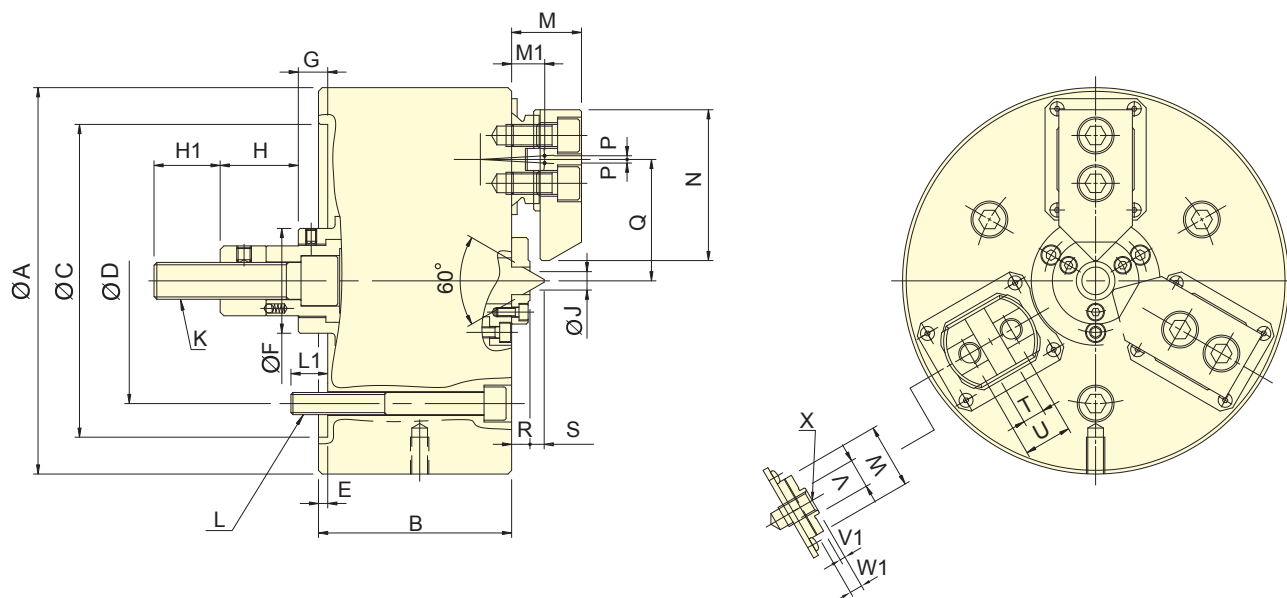

保留規格修改的權利  
Subject to technical changes

### 技術規格 SPECIFICATIONS

型號	楔心行程	爪行程 (直徑)	夾持直徑 Chuck Dia.		容許最大入力	最大夾持力	最高迴轉數	I	重量	適用迴轉缸	補償量
			最大 Max.	最小 Min.							
Model	Plunger stroke	Jaw stroke (Dia.)	mm	mm	kN (kgf)	kN (kgf)	min <sup>-1</sup> (r.p.m.)	kg · m <sup>2</sup>	kg		mm
<b>3R-08</b>	20	8	65	18	19.6(2000)	53.0(5404)	2800	0.15	27	RK-100N	2
<b>3R-10</b>	25	10	90	22	29.4(3000)	67.7(6901)	2500	0.38	45	RK-125N	2

### 外型尺寸 DIMENSIONS

Model	A	B	C (H6)	D	E	F	G max.	G min.	H	H1	J	K	L	L1
<b>3R-08</b>	210	105	170	133.4	5	57	26	6	42.5	36	10.4	M20x2.5	3~M12	20
<b>3R-10</b>	254	115	220	171.4	5.5	64	36.5	11.5	25	39	15	M20x2.5	3~M16	22.5

  

Model	M	M1	N	P	Q max.	Q min.	R	S	T (H7)	U	V	V1	W	W1	X
<b>3R-08</b>	38	18	82	2	68	64	10	7.7	12	26	16	3	35	7	M12
<b>3R-10</b>	40	19	102	2.6	82	78	10	11.3	15	32	18	3	40	7	M14

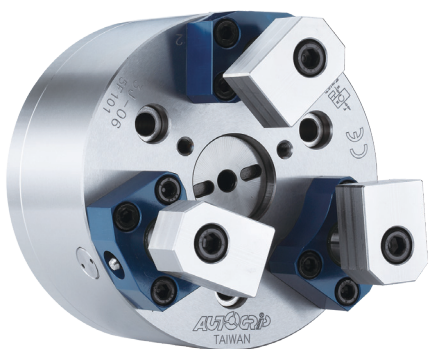

- 採工件端面夾持，防止工件夾持變形，適合薄壁工件加工。
  - 夾持補償機構，可夾持不規則端面之工件。
  - Gripping at the end face and preventing deformation of workpiece.
  - Suitable for thin wall workpiece processing.
  - The gripping compensating mechanism can grasp the irregular surface workpieces well.
- 氣密檢知 (選配)。  
■ Airtight pressure detect function is optional.

特殊動力夾頭

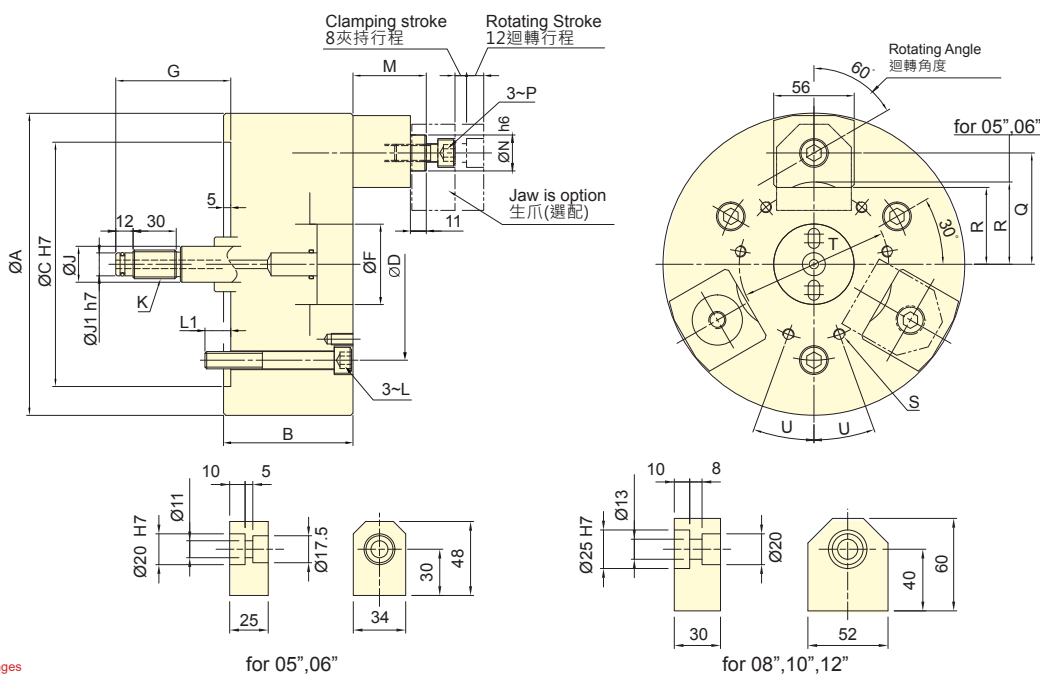
 保留規格修改的權利  
 Subject to technical changes

### 技術規格 SPECIFICATIONS

型號	迴轉行程	夾持行程	爪補償量	夾持直徑 Chuck Dia.		容許最大入力	最大夾持力	最高迴轉數	I	重量	適用迴轉缸	最大使用壓力
Model	Rotating stroke	Clamping stroke	Jaw's compensation	最大 Max.	最小 Min.	Max. D.B. pull	Max. Clamping force	Max. speed	Moment of inertia	Weight	Matching cyl.	Max. pressure
	mm	mm	mm	mm	mm	kN (kgf)	kN (kgf)	min <sup>-1</sup> (r.p.m.)	kg · m <sup>2</sup>	kg		MPa (kgf/cm <sup>2</sup> )
3J-05	12	8	2	53	25	7.5(765)	6.0(612)	4000	0.02	11.0	RK-100 OR RK-100(N)	1.0(10)
3J-06	12	8	2	79	55	9.0(918)	7.5(765)	4000	0.04	12.0	RK-100 OR RK-100(N)	1.2(12)
3J-08	12	8	2	106	75	18.0(1835)	16.5(1680)	3500	0.13	23.0	RK-100 OR RK-100(N)	2.5(25)
3J-10	12	8	2.5	150	119	18.0(1835)	16.5(1680)	3500	0.30	33.0	RK-100 OR RK-100(N)	2.5(25)
3J-12	12	8	2.5	200	169	18.0(1835)	16.5(1680)	3000	0.56	44.0	RK-100 OR RK-100(N)	2.5(25)

### 外型尺寸 DIMENSIONS

Model	A	B	C	D	F	G max.	G min.	J	J1	K
3J-05	135	86	110	82.6	40	75	55	25	9	M12x1.75
3J-06	165	86	140	104.8	45	75	55	28	12	M16x2
3J-08	210	90	170	133.4	56	80	60	38	16	M20x2.5
3J-10	254	95	220	171.4	56	75	55	38	16	M20x2.5
3J-12	304	95	220	171.4	56	75	55	38	16	M20x2.5

Model	L	L1	M max.	M min.	N	P	Q	R	S	T	U
3J-05	M10	15	56	36	20	M10	42.5	27	3~M6	50	-
3J-06	M10	15	56	36	20	M10	57.5	40	3~M8	64	-
3J-08	M12	18	71	51	25	M12	77.5	53.5	6~M8	104	20°
3J-10	M16	24	71	51	25	M12	99.5	75.5	6~M8	140	20°
3J-12	M16	24	71	51	25	M12	124.5	100.5	6~M8	190	20°



- 採工件端面夾持，防止工件夾持變形，適合薄壁工件加工。
  - 夾持補償機構，可夾持不規則端面之工件。
  - Gripping at the end face and preventing deformation of workpiece.
  - Suitable for thin wall workpiece processing.
  - The gripping compensating mechanism can grasp the irregular surface workpieces well.
- 氣密檢知 (選配)。
  - Airtight pressure detect function is optional.

特殊動力夾頭

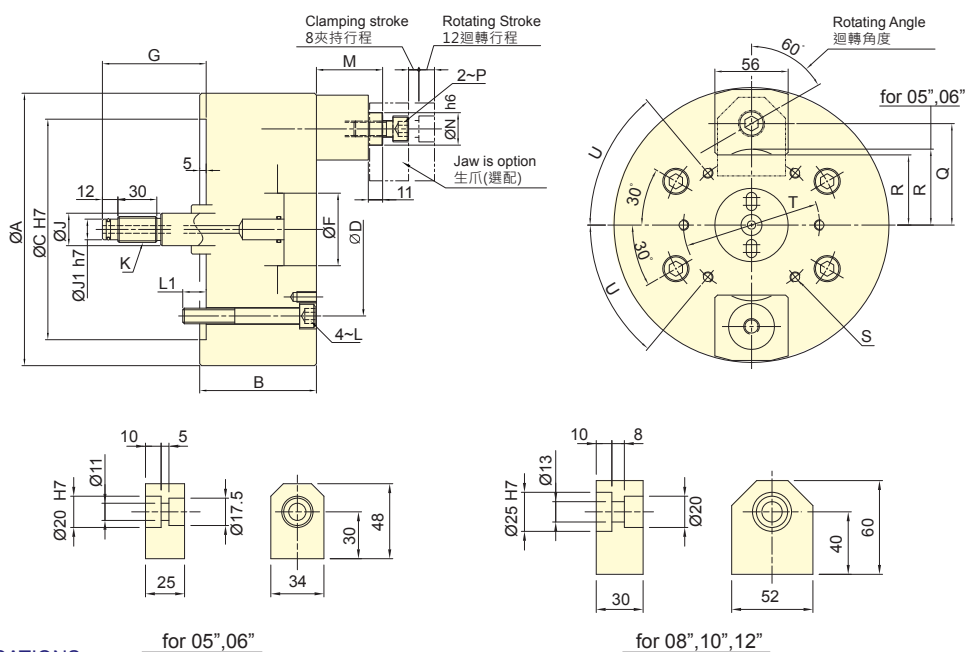
 保留規格修改的權利  
 Subject to technical changes

### 技術規格 SPECIFICATIONS

型號	迴轉行程	夾持行程	爪補償量	夾持直徑		容許最大入力	最大夾持力	最高迴轉數	I	重量	適用迴轉缸	最大使用壓力
				最大	最小							
Model	Rotating stroke	Clamping stroke	Jaw's compensation	Max.	Min.	Max. D.B. pull	Max. Clamping force	Max. speed	Moment of inertia	Weight	Matching cyl.	Max. pressure
	mm	mm	mm	mm	mm	kN (kgf)	kN (kgf)	min <sup>-1</sup> (r.p.m.)	kg · m <sup>2</sup>	kg		MPa (kgf/cm <sup>2</sup> )
2J-05	12	8	2	53	25	5.0(510)	4.0(408)	4000	0.015	9.0	RK-100 OR RK-100(N)	0.7(7)
2J-06	12	8	2	79	55	6.0(612)	5.0(510)	4000	0.035	9.8	RK-100 OR RK-100(N)	0.8(8)
2J-08	12	8	2	106	75	12.0(1224)	11.0(1122)	3500	0.12	20.3	RK-100 OR RK-100(N)	1.7(17)
2J-10	12	8	2.5	150	119	12.0(1224)	11.0(1122)	3500	0.28	30.7	RK-100 OR RK-100(N)	1.7(17)
2J-12	12	8	2.5	200	169	12.0(1224)	11.0(1122)	3000	0.52	41.2	RK-100 OR RK-100(N)	1.7(17)

### 外型尺寸 DIMENSIONS

Model	A	B	C	D	F	G max.	G min.	J	J1	K
2J-05	135	86	110	82.6	40	75	55	25	9	M12x1.75
2J-06	165	86	140	104.8	45	75	55	28	12	M16x2
2J-08	210	90	170	133.4	56	80	60	38	16	M20x2.5
2J-10	254	95	220	171.4	56	75	55	38	16	M20x2.5
2J-12	304	95	220	171.4	56	75	55	38	16	M20x2.5

Model	L	L1	M max.	M min.	N	P	Q	R	S	T	U
2J-05	M10	15	56	36	20	M10	42.5	27	4~M6	50	30°
2J-06	M10	15	56	36	20	M10	57.5	40	4~M8	64	30°
2J-08	M12	18	71	51	25	M12	77.5	53.5	6~M8	104	50°
2J-10	M16	24	71	51	25	M12	99.5	75.5	6~M8	140	50°
2J-12	M16	24	71	51	25	M12	124.5	100.5	6~M8	190	50°

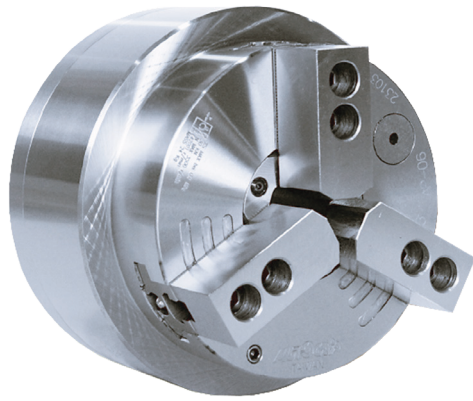

- 超大通孔徑氣動夾頭·內藏氣壓缸·適合管材加工。
- 專利注氣系統·安裝快速容易·無傳統注氣密封環損壞問題·可節省安裝及維修成本。
- Large through-hole 3-jaw power chuck with build in air cylinder.
- Patented air supply system, it is easy to install and maintain. No abrasion issue of traditional sealed ring. Maintenance cost and time can be saved.

■ 專利產品字號 Patent numbers :

德國 : 20.2011.101.818.4 / 20.2012.102.498.5 (Germany)  
 日本 : 3169457 / 3178706 (Japan) / 歐盟 : EP 2517822 B1 (EU)  
 大陸 : ZL 2011 2 0141324.9 / ZL 2012 2 0274549.6 (China)  
 台灣 : M440159 / M415011 (Taiwan) / 美國 : US8770222 B2 (U.S.A.)  
 義大利 : 0000278076 (Italy)

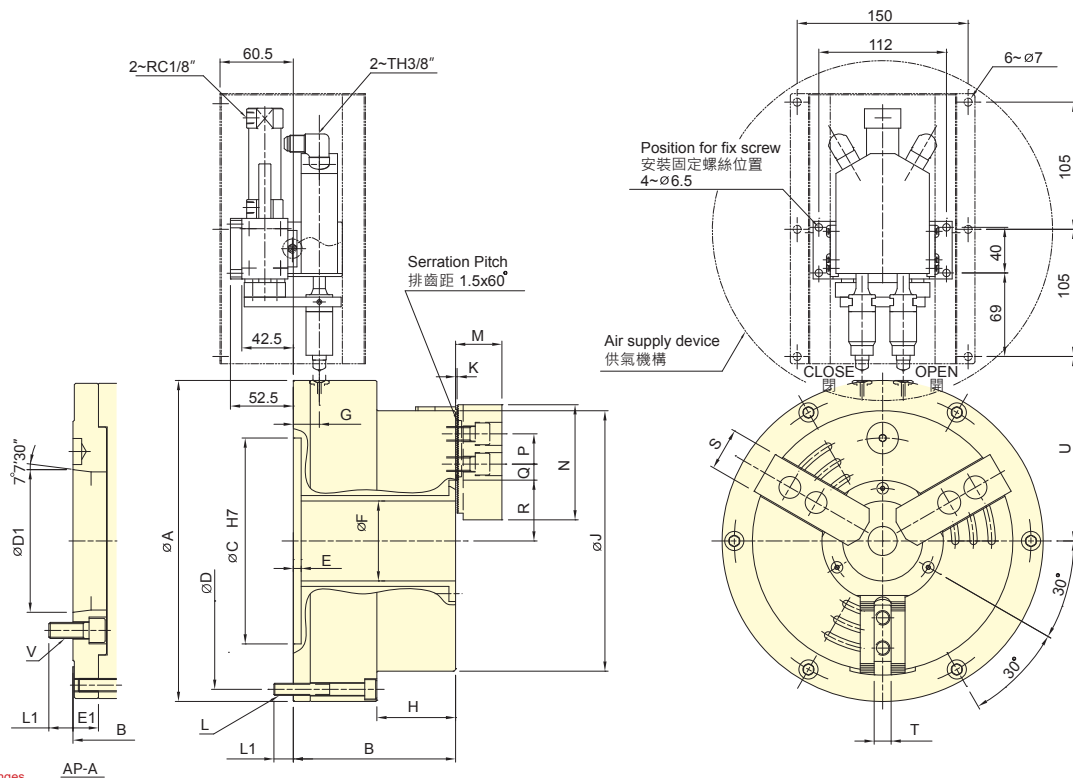

保留規格修改的權利  
Subject to technical changes

### 技術規格 SPECIFICATIONS

型號 Model	通孔徑 Thru-hole Dia.	爪行程(直徑) Jaw stroke (Dia.)	夾持直徑 Chuck Dia.		最大使用壓力 Max. pressure	最大夾持力 Max. Clamping force	最高迴轉數 Max. speed	I Moment of inertia	重量 Weight	空氣消耗量 (使用壓力 6kgf/cm <sup>2</sup> ) Air Consumption	
			最大 Max.	最小 Min.							MPa (kgf/cm <sup>2</sup> )
AP-52	A6	52	5.9	170	15	0.6(6.1)	40.5(4128)	3900	0.2	26 <b>30</b>	3.1
AP-66	A6	66	7.6	215	24	0.6(6.1)	50(5097)	3000	0.4	38 <b>45</b>	5.1
AP-86	A8	86	8.9	268	43	0.6(6.1)	80(8156)	2800	0.7	58 <b>72</b>	8.7
AP-115	A8	115	10.6	330	55	0.6(6.1)	90(9174)	2000	1.7	92 <b>112</b>	12

### 外型尺寸 DIMENSIONS

Model	A	B	C	D	D1	E	E1	F	G	H	J	K	L		
AP-52	A6	235	121	<b>140</b>	170	215	<b>106.38</b>	6.5	<b>19</b>	52	21.5	58.5	170	2	6~M10
AP-66	A6	265	134	<b>153</b>	170	245	<b>106.38</b>	6.5	<b>19</b>	66	21.5	65	215	2	6~M10
AP-86	A8	315	142	<b>169</b>	220	295	<b>139.72</b>	6.5	<b>27</b>	86	21.5	67	268	2	6~M10
AP-115	A8	370	154	<b>181</b>	220	350	<b>139.72</b>	6.5	<b>27</b>	115	21.5	69	330	2	6~M10

Model	L1	M	N	P	Q max.	Q min.	R max.	R min.	S	T	U	V		
AP-52	A6	15	<b>18</b>	37	73	20	21.2	9.2	38	35.1	31	12	145.5	<b>6~M12</b>
AP-66	A6	16	<b>18</b>	38	95	25	23.7	8.7	50.2	46.4	35	14	159.5	<b>6~M12</b>
AP-86	A8	16	<b>24</b>	43	110	30	32.2	12.7	62.2	57.8	40	16	184.5	<b>6~M16</b>
AP-115	A8	16	<b>24</b>	51	130	30	44.7	14.7	77	71.7	50	21	212	<b>6~M16</b>

紅色數據為 AP-A 型之寸法 (The dimensions and the specifications of AP-A type are in red data.)

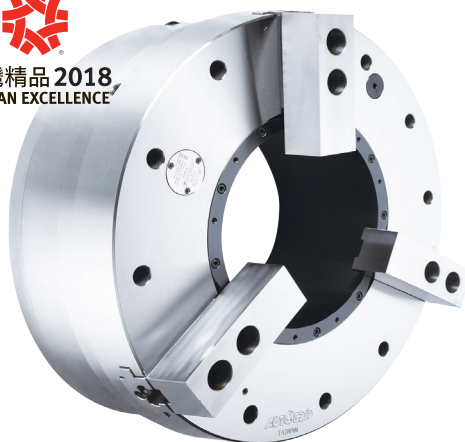

- 超大通孔徑氣動夾頭，內藏氣壓缸，適合管材加工。
- 夾頭內建有“壓力檢知”機構，能檢知夾頭內部壓力遽降，確保操作安全。
- 專利注氣系統，安裝快速容易，無傳統注氣密封環損壞問題，可節省安裝及維修成本。
- Large through-hole 3-jaw power chuck with built in air cylinder.
- With built-in "pressure detection" device in chuck which can check the pressure is lowered rapidly within the chuck, guarantee to the security of operating.
- Patented air supply system, it is easy to install and maintain. No abrasion issue of traditional sealed ring. Maintenance cost and time can be saved.
- 專利產品字號 Patent numbers :
  - 德國：20.2011.101.818.4 / 20.2012.102.498.5(Germany)
  - 日本：3169457 / 3178706 (Japan) / 歐盟：EP 2517822 B1 (EU)
  - 大陸：ZL 2011 2 0141324.9 / ZL 2012 2 0274549.6 (China)
  - 台灣：M440159 / M415011 (Taiwan) / 美國：US8770222 B2 (U.S.A.)
  - 義大利：0000278076(Italy)

特殊動力夾頭

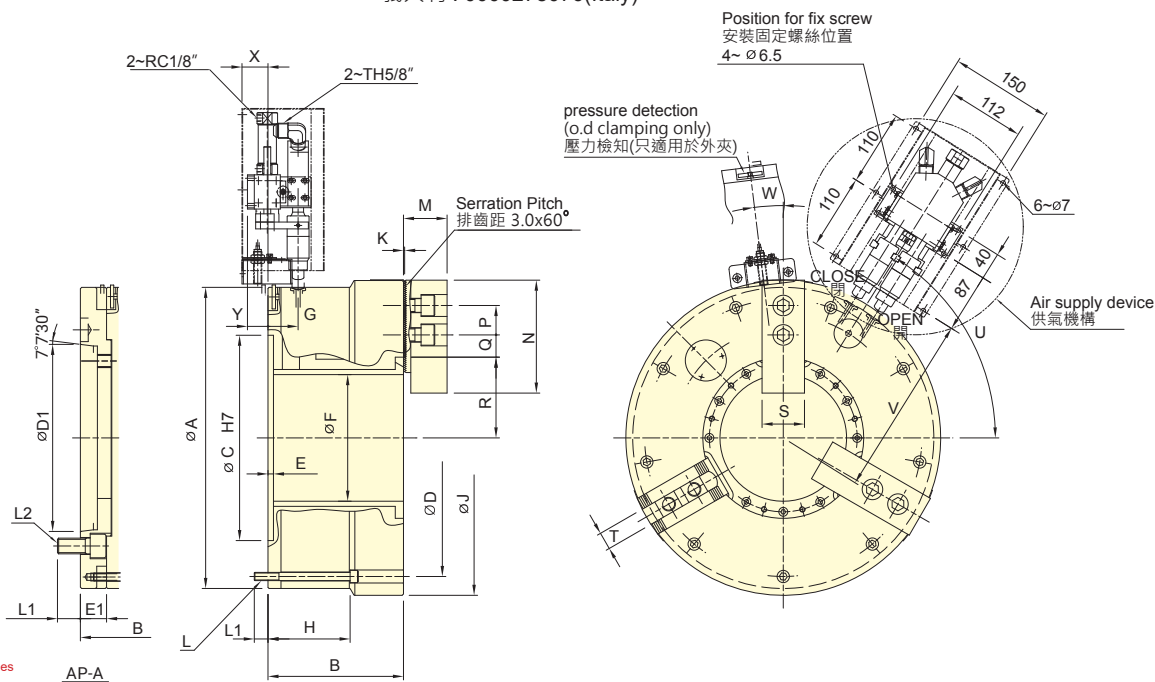

保留規格修改的權利  
Subject to technical changes

### 技術規格 SPECIFICATIONS

型號 Model	通孔徑 Thru-hole Dia.	爪行程 (直徑) Jaw stroke (Dia.)		夾持直徑 Chuck Dia.		最大使用壓力 Max. pressure	最大夾持力 Max. Clamping force	最高迴轉數 Max. speed	I Moment of inertia	重量 Weight	空氣消耗量 (使用壓力 6kgf/cm <sup>2</sup> ) Air Consumption	
		mm	mm	最大 Max.	最小 Min.							MPa (kgf/cm <sup>2</sup> )
AP-145	A11	145	14	420	62	0.6(6.1)	110(11213)	1500	3.8	156	182	17.8
AP-185	A15	185	14	460	100	0.6(6.1)	160(16310)	1700	6.0	188	223	22
AP-230	A15	230	17	535	170	0.6(6.1)	150(15290)	1300	11.1	265	310	34
AP-275	A20	275	17	580	200	0.6(6.1)	160(16310)	1100	15.5	301	346	39
AP-320	A20	320	17	658	200	0.6(6.1)	180(18348)	1000	27.2	415	505	45
AP-375	A20	375	24	738	260	0.6(6.1)	210(21406)	900	44.2	530	545	55

### 外型尺寸 DIMENSIONS

Model	A	B	C	D	D1	E	E1	F	G	H	J	K	L	L1			
AP-145	A11	400	198	231	300	365	196.87	8	33	145	34	120	420	3.5	9~M12	20	31
AP-185	A15	460	198	238	300	405	285.78	8	40	185	44	120	460	3.5	9~M12	20	35
AP-230	A15	515	226	266	380	483	285.78	8	40	230	49	145	535	3.5	6~M16	24	35
AP-275	A20	560	232	272	380	528	412.78	8	40	275	52	152	580	3.5	6~M16	24	35
AP-320	A20	615	256	306	520	580	412.78	8	50	320	55	116.5	658	3.5	9~M16	25	33
AP-375	A20	690	272	322	520	650	412.78	8	50	375	55	127	738	3.5	9~M16	28	33

Model	L2	M	N	P	Q max.	Q min.	R max.	R min.	S	T	U	V	W	X	Y	
AP-145	A11	6~M20	63.7	165	43	53.5	23.5	98	91	62	25.5	57°	242	0°	38	20
AP-185	A15	6~M24	63.7	165	43	53.5	23.5	118	111	62	25.5	58°	272	7°	38	20
AP-230	A15	6~M24	71.7	180	60	48.5	18.5	145	136.5	64	25.5	30°	300	7°	33	15
AP-275	A20	6~M24	71.7	180	60	48.5	18.5	167.5	159	64	25.5	30°	322	7°	30	12
AP-320	A20	6~M24	81.5	210	60	60.5	24.5	190	181.5	74	30	52°	350	7°	27	9
AP-375	A20	6~M24	81.5	210	60	66.5	24.5	223.5	211.5	74	30	52°	387	7°	27	9

紅色數據為 AP-A 型之寸法 (The dimensions and the specifications of AP-A type are in red data.)



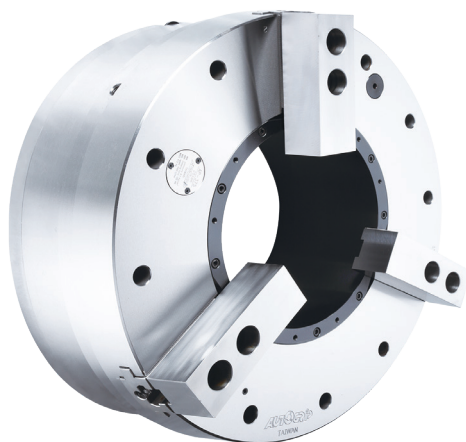

- 超大通孔徑氣動夾頭，內藏氣壓缸，適合管材加工。
- 夾頭內建有"壓力檢知"機構，能檢知夾頭內部壓力遽降，確保操作安全。
- 專利注氣系統，安裝快速容易，無傳統注氣密封環損耗問題，可節省安裝及維修成本。
- 夾頭內建有"夾持檢知"機構，能避免夾爪於快速位移行程中夾持工件，進而導致內部零件損壞或工件飛脫所設計之機構。(只適用於外徑夾持)
- 兩段式行程，可節省夾持所需要時間。
- Large through-hole 3-jaw power chuck with build in air cylinder.
- With build-in "pressure detection" device which can check the rapidly decreasing pressure within the chuck, guarantee to the security when operating.
- Patented air supply system, it is easy to install and maintain. No abrasion issue of traditional sealed ring. Maintenance cost and time can be saved.
- The build-in "clamping detection" device can avoid jaws clamping the workpiece during the rapid stroke stage. This mechanism can also prevent causing the damage of the internal parts or flying out of workpiece.(only for external clamping)
- Extended jaw stroke design can shorten the processing time when gripping.
- 注意：快速行程階段無法提供足夠之夾持力。
- Notice: No clamping in rapid stroke period.

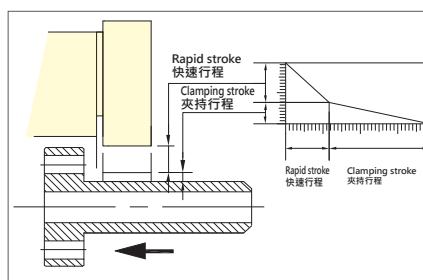
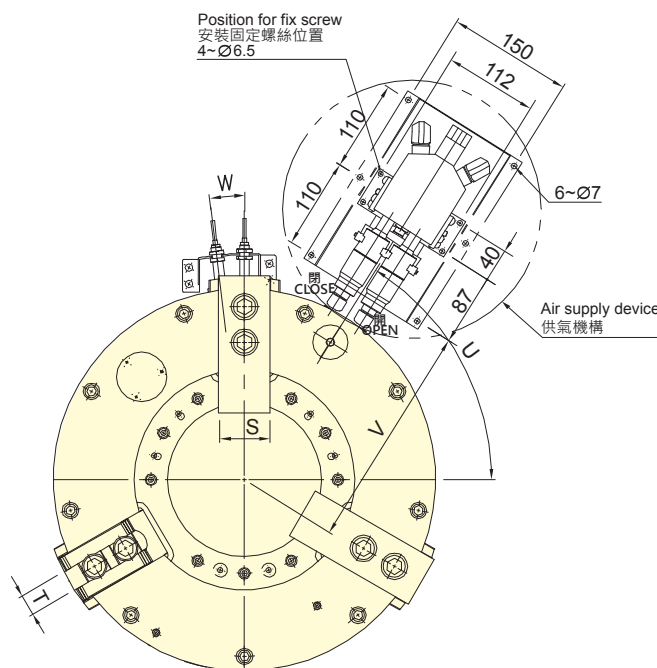
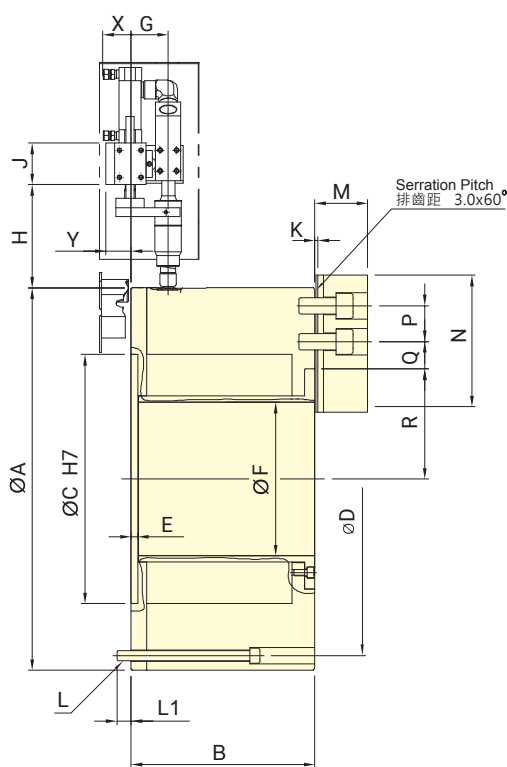

保留規格修改的權利 Subject to technical changes

### 技術規格 SPECIFICATIONS

型號 Model	通孔徑 Thru-hole Dia. mm	爪行程 (直徑) Jaw stroke (Dia.) mm		夾持直徑 Chuck Dia. mm		最大夾持力 Max. Clamping force kN (kgf)	最高迴轉數 Max. speed min <sup>-1</sup> (r.p.m.)	I Moment of inertia kg · m <sup>2</sup>	重量 Weight kg	空氣消耗量 (使用壓力 6kgf/cm <sup>2</sup> ) Air Consumption lit(at 6kgf/cm <sup>2</sup> )
		最大 Max.	最小 Min.	最大 Max.	最小 Min.					
<b>APS-185</b>	185	26	14	460	127	110(11216)	1300	6.45	198	22

### 外型尺寸 DIMENSIONS

Model	A	B	C	D	E	F	G	H	J	K	L	L1	M
<b>APS-185</b>	460	221	300	425	8	185	45	124	50	3.5	9-M12	17	63.7
Model	N	P	Q max.	Q min.	R max.	R min.	S	T	U	V	W	X	Y
<b>APS-185</b>	165	43	37	17	145	125	62	25.5	58	272	7°	38	30